

iGuzzini

WALKY

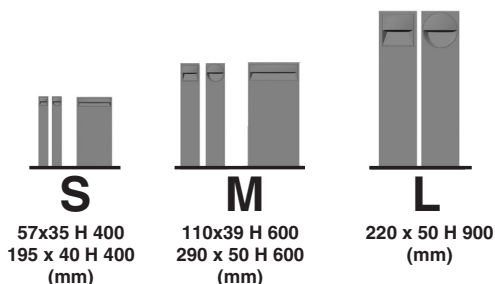

IT ATTENZIONE:

LA SICUREZZA DELL'APPARECCHIO E' GARANTITA SOLO CON L'USO APPROPRIATO DELLE SEGUENTI ISTRUZIONI; PERTANTO E' NECESSARIO CONSERVARLE.

EN WARNING:

THE SAFETY OF THIS FIXTURE IS GUARANTEED ONLY IF YOU COMPLY WITH THESE INSTRUCTIONS; REMEMBER TO CONSERVE IN A SAFE PLACE.

FR ATTENTION:

LA SECURITE DEL'APPAREIL N'EST GARANTIE QU'EN CAS D'UTILISATION CORRECTE DES INSTRUCTIONS SUIVANTES; IL FAUT PAR CONSEQUENT LES CONSERVER.

DE ACHTUNG:

DIE SICHERHEIT DES GERÄTES WIRD NUR DURCH SACHGEMÄSSE BEFOLGUNG NACHSTEHENDER ANWEISUNGEN GEWÄHRLEISTET; IHRE AUFBEWAHRUNG IST DESHALB SEHR WICHTIG.

NL OPGELET:

DE VEILIGHEID VAN DI ATOESTEL IS SLECHTS DAN GEGARANDEERD ALS INDIEN DE VOLGENDE INSTRUCITIES STRIKT WORDEN TOEGEPAST: DAAROM MOET MEN ZE OOK BEWAAREN.

ES ATENCION:

LA SEGURIDAD DEL APARATO SE GARANTIZA SOLO CUMPLIENDO CUIDADOSAMENTE LAS SIGUIENTES INSTRUCCIONES; POR ELLO, ES NECESARIO CONSERVARLAS.

DA BEMÆRK:

SIKKERHEDEN VED BRUG AF ARMATURET KAN KUN GARANTERES, HVIS DISSE ANVISNINGER FØLGES; SØRG DERFOR FOR AT GEMME DEM.

NO ADVARSEL:

SIKKERHETEN TIL DETTE APPARATET GARANTERES KUN HVIS DU OVERHOLDER DISSE INSTRUKSJONENE; HUSK Å OPPBEVARE DEM PÅ ET TRYGT STED.

SV OBSERVERA!

UTRUSTNINGENS SÄKERHET KAN ENDAST GARANTERAS OM DESSA ANVISNINGAR RESPEKTERAS I DETALJ. SPARA DÄRFÖR DESSA ANVISNINGAR FÖR FRAMTIDA KONSULTATION.

RU ВНИМАНИЕ:

МЫ ГАРАНТИРУЕМ БЕЗОПАСНУЮ ЭКСПЛУАТАЦИЮ ИЗДЕЛИЯ ТОЛЬКО ПРИ СОБЛЮДЕНИИ СЛЕДУЮЩИХ ИНСТРУКЦИЙ; С ЭТОЙ ЦЕЛЬЮ НЕОБХОДИМО СОХРАНИТЬ ДАННУЮ БРОШЮРУ.

警告

ZH 为确保该装置安全，请遵守操作指示；并于安全场所放置。

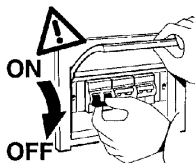

IT N.B.: DURANTE L'INSTALLAZIONE DEL SISTEMA RISPETTARE SCRUPOLOSAMENTE LE NORME IMPIANTISTICHE NAZIONALI VIGENTI.

EN N.B.: WHEN INSTALLING THE SYSTEM, MAKE SURE ALL CURRENT NATIONAL REGULATIONS RELATING TO INSTALLATION ARE OBSERVED.

FR N.B.: LORS DE L'INSTALLATION DU SYSTÈME VEUILLEZ RESPECTER RIGOREUSEMENT LES NORMES EN VIGUEUR EN LA MATIÈRE DANS LE PAYS.

DE N.B.: BEACHTEN SIE BEI DER INSTALLATION DES SYSTEMS UNBEDINGT DIE IM LAND GELTENDEN ANLAGETECHNISCHEN VORSCHRIFTEN.

NL N.B.: BIJ HET INSTALLEREN VAN HET SYSTEEM MOET U DE GELDENDE NATIONALE INSTALLATIENORMEN STRIKT NALEVEN.

ES NOTA: DURANTE LA INSTALACIÓN DEL SISTEMA RESPETAR ESCRUPULOSAMENTE LAS NORMAS NACIONALES DE INSTALACIÓN EN VIGOR.

DA N.B.: UNDER INSTALLATION AF SYSTEMET SKAL MAN NØJE OVERHOLDE DE GÆLDENDE REGLER FOR DISSE ANLÆG.

NO N.B.: UNDERINSTALLASJON AV SYSTEMET MÅ DENASJONALE ANLEGGSFORSKRIFTENE OVERHOLDES NØYE.

SV OBS! UNDER INSTALLATIONEN AV SYSTEMET SKA GÄLLANDE NATIONELLA INSTALLATIONSFORESKRIFTER RESPEKTERAS I DETALJ.

RU ПРИМЕЧАНИЕ: В ПРОЦЕССЕ МОНТАЖА СИСТЕМЫ СТРОГО СОБЛЮДАЙТЕ НАЦИОНАЛЬНЫЕ ДЕЙСТВУЮЩИЕ НОРМАТИВЫ ПО ЭЛЕКТРОПРОВОДКЕ.

ZH 注意：安装系统时请务必遵守系统标准。

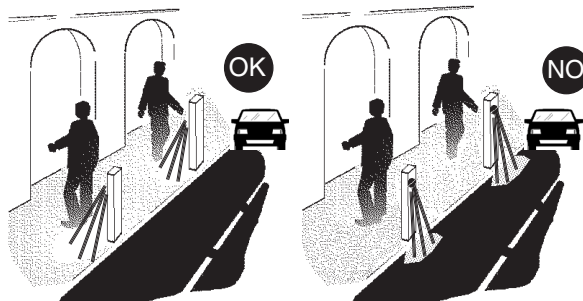

IT Posizioni d'installazione diverse da quelle indicate non sono consentite.

EN Installation positions different to those indicated are not allowed.

FR Aucune autre position d'installation que celles indiquées n'est permise.

DE Andere als die angegebenen Positionen für die Installation sind nicht zugelassen.

NL Het is niet toegestaan de apparaten op een andere manier te installeren dan aangegeven.

ES No se permiten posiciones de instalación diferentes de las indicadas.

DA Andre installationstyper og - positioner end de angivne er ikke tilladt.

NO Installasjonsstillinger bortsett fra de som angis, er ikke tillatt.

SV Andra installationspositioner än de som föreskrivs är inte tillåtna.

RU Не допускается монтажное положение, отличное от указанного в настоящем тех. руководстве.

ZH 安装在与指定位置不同的地方是不被允许的。

Size	Art.	V	A mm	B mm	H mm	Art.	Art.
L	X436	230V	220	50	900	X	X447
L	X440	230V	220	50	900	X	X447
M	X437	24V	110	39	600	X	X448
M	X438	24V	110	39	600	✓	X448
M	X441	24V	110	39	600	X	X448
M	X442	24V	110	39	600	✓	X448
S	X439	24V	57	35	400	X	X449
S	X443	24V	57	35	400	X	X449
M	X444	24V	290	50	600	X	X450
M	X445	24V	290	50	600	✓	X450
S	X446	24V	195	40	400	X	X451

IT N.B.: Installando l'apparecchio, evitare che la base venga interrata o posizionata in punti soggetti al ristagno dell'acqua.

EN N.B.: Whilst installing the appliance, avoid concealing its base or placing it in areas which are susceptible to damp.

FR N.B.: Lors de l'installation de l'appareil, veillez à ce que la base ne soit pas enterrée ou positionnée dans un endroit sujet à la stagnation de l'eau.

DE N.B.: Bei der Installation des Gerätes ist darauf zu achten, daß das Unterteil nicht eingegraben oder an Stellen placiert wird, an denen sich Wasser stauen könnte.

NL N.B.: Het apparaat mag niet met de basis ingebouwd worden of op punten geïnstalleerd die stilstaand water veroorzaken.

ES NOTA: Al instalar el aparato, evite que la base se entierre o se coloque en puntos donde se pueda estancar el agua.

DA N.B.: Ved installation af armaturet skal man undgå, at skolen er under niveau eller placeres på et sted, hvor der ophobes vand.

NO N.B.: Under installasjon av apparatet, unngå å skjule basen eller plassere den på områder som er utsatt for damp.

SV OBS! När utrustningen installeras ska du undvika att basen hamnar under marken eller placeras på ställen där vatten ansamlas.

RU ПРИМЕЧАНИЕ: При монтаже прибора следует избегать зарывания в почву или установки его основания в местах, подверженных затоплению.

ZH 注意：安装该灯具时，避免隐藏底座或将灯具放置在易受潮的区域。

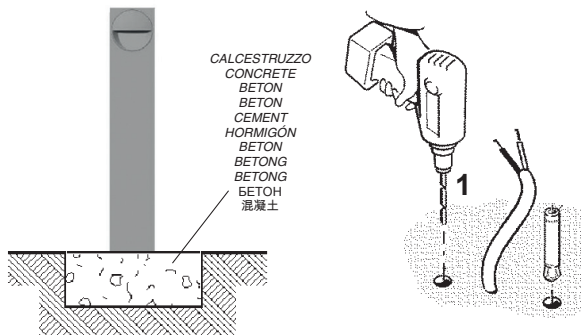
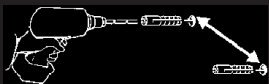

CALCESTRUZZO
CONCRETE
BETON
CEMENT
HORMIGÓN
BETON
BETONG
BETOH
混凝土

- IT PER IL FISSAGGIO SI CONSIGLIA DI UTILIZZARE TASSELLI PER ANCORAGGI PESANTI TIPO FZA- I- M8 / M5 FISCHER, O SIMILARI ANCHE DI ALTRI COSTRUTTORI .
- EN FOR FIXING USE HEAVY DUTY PLUGS, SUCH AS FZA- I- M8 / M5 FISCHER OR SIMILAR, INCLUDING FROM OTHER MANUFACTURERS.
- FR POUR LA FIXATION, IL EST CONSEILLÉ D'UTILISER DES CHEVILLES POUR ANCRAGES LOURDS DE TYPE FZA- I- M8 / M5 FISCHER OU SIMILAIRES (D'AUTRES FABRICANTS AUSSI).
- DE ZUR BEFESTIGUNG EMPFEHLEN WIR, STARKE VERANKERUNGSDÜBEL ZU VERWENDEN, ZUM BEISPIEL VOM TYP FZA-I-M8 / M5 VON FISCHER ODER ENTSPRECHENDE PRODUKTE VON ANDEREN HERSTELLERN.
- NL VOOR DE BEVESTIGING RADEN WIJ U AAN PLUGGEN VOOR ZWARE VERANKERINGEN TE GEBRUIKEN, ZOALS HET TYPE FZA- I- M8 / M5 FISCHER OF DERGELIJKE, OOK VAN ANDERE PRODUCENTEN .
- ES PARA LA FIJACIÓN SE RECOMIENDA UTILIZAR TACOS PARA ANCLAJES DE GRAN RESISTENCIA, TIPO FZA-I- M8 / M5 FISCHER, O SIMILARES, INCLUSO DE OTROS FABRICANTES.
- DA VED MONTERING ANBEFALES BRUG AF RAWLPLUGS TIL TUNGE EMNER AF TYPEN FZA- I- M8 / M5 FISCHER, ELLER LIGNENDE FRA ANDRE FABRIKANTER.
- NO FOR FESTE BRUKES HØYTYTELSESLUGGER, SLIK SOM FZA- I- M8 / M5 FISCHER ELLER LIGNENDE, INKLUDERT FRA ANDRE PRODUSENTER.
- SV FÖR FASTSÄTTNINGEN REKOMMENDERAS ATT ANVÄNDA PLUGGAR FÖR FASTSÄTTNING AV TYNGRE FÖREMÅL AV TYP FZA- I- M8 / M5 FISCHER, ELLER LIKNANDE AV ANNAT MÄRKE.
- RU для крепления рекомендуется использовать вкладыши для тяжелого крепления типа FZA- I- M8 / M5 FISCHER или подобные других марок.
- ZH 进行固定时, 使用大载流插头, 例如FZA- I- M8 / M5 FISCHER 或SIMILAR, 也包括其他生产商提供的插头。

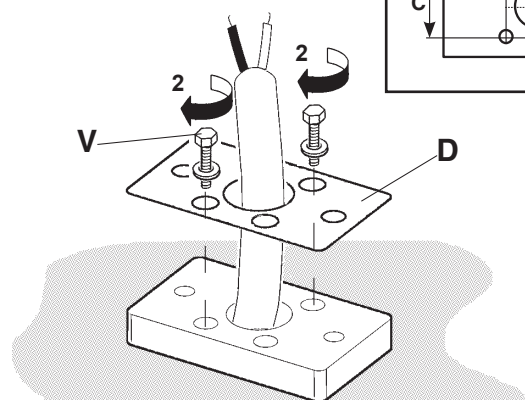
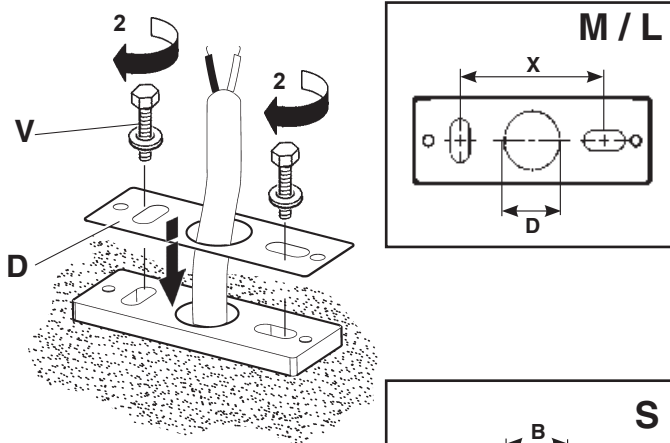

ART.	X (mm)	B (mm)	C (mm)	D (mm)	V (mm)
X436 - X440	140	/	/	25	M8
X437 - X438 - X441 - X442	65				
X444 - X445	200				
X446	120				
X439 - X443	/	16	20	14	M5

+ art. X447 - X448 - X449 - X450 - X451

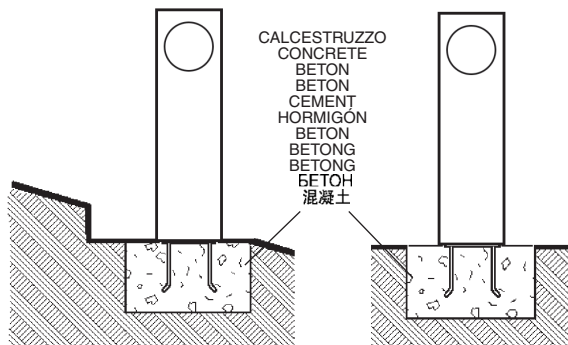

CALCESTRUZZO
CONCRETE
BETON
CEMENT
HORMIGÓN
BETON
BETONG
BETOH
混凝土

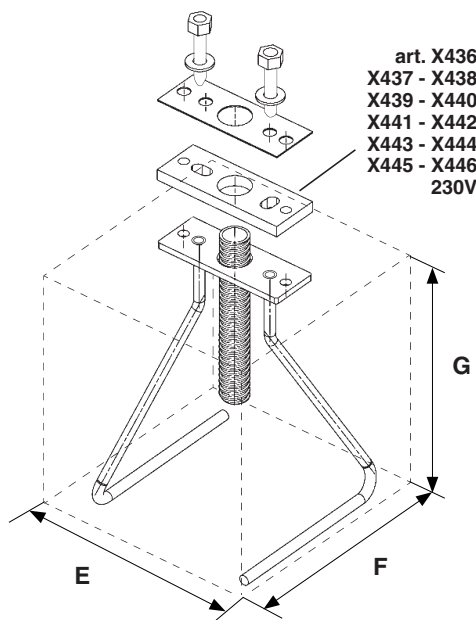

art. X436
X437 - X438
X439 - X440
X441 - X442
X443 - X444
X445 - X446
230V

ART.	E (mm)	F (mm)	G (mm)
X436 - X440	350	350	350
X437 - X438 - X441 - X442	300	300	300
X444 - X445	400	300	300
X446	300	250	250
X439 - X443	250	250	250

- IT N.B.: Le dimensioni del Plinto sono fornite a titolo indicativo, sono state calcolate considerando un terreno con pressione ammissibile di 1,0bar (1,0 kg/cm²)
- EN N.B.: The dimensions of the plinth are purely indicative and were calculated taking into account a surface with an allowable pressure of 1.0 bar (1.0 kg/cm²)
- FR N.B.: Les dimensions du massif de fondation sont fournies à titre indicatif et ont été calculées en tenant compte d'un sol dont la pression admise est égale à 1,0 bar (1,0 kg/cm²)
- DE N.B.: Die Abmessungen der Plinthe sind als Richtwert angegeben und wurden für ein Gelände mit zulässigem Druck von 1,0 bar (1,0 kg/cm²) berechnet
- NL N.B.: De afmetingen van Plinto zijn slechts als voorbeeld vervaardigd. Zij zijn berekend op basis van een bodem met een toegestane druk van 1,0 bar (1,0 kg/cm²).
- ES NOTA: Las medidas de Plinto son sólo indicativas, han sido calculadas considerando un terreno con presión admisible de 1,0bar (1,0 kg/cm²)
- DA N.B.: Dimensionerne på Plinto er omtrentlige. De er beregnet ud fra et maks. tilladt jordtryk på 1,0 bar (1,0 kg/cm²)
- NO N.B.: Størrelsen på pilaren gis kun som et eksempel, den er utregnet på grunnlag av et terreng med et tillatt trykk på 1,0 bar (1,0 kg/cm²)
- SV OBS! Måtten som anges för Plinto är endast ungefärliga och har beräknats på en mark med ett tillåtet tryck på 1,0 bar (1,0 kg/cm²)
- RU ПРИМЕЧАНИЕ: Размеры Plinto, приведенные только в качестве примера, были рассчитаны с учетом почвы с допустимым давлением 1,0 бар (1,0 кг/см²)
- ZH 注意: 底座的外形尺寸完全是参考性的并且表面的容许压力1.0 bar (1.0 kg/cm²)要被计算考虑在内。

Proteggere la parte verniciata.
 Protect the painted part.
 Protégez la partie peinte.
 Lackierte Seite schützen.
 Bescherm het gelakte gedeelte.
 Proteger la parte barnizada.
 Afdæk den lakerede del.
 Beskytt den lakkerte delen.
 Skydda den lackerade delen.
 Предохраните покрашенную сторону.
 保护上漆部件。

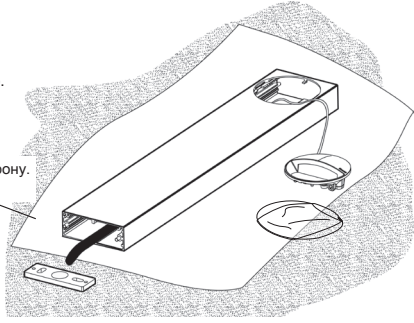

IT Consultare il foglio istruzioni del prodotto.

EN Refer to the product instruction sheet.

FR Veuillez consulter la notice d'instructions du produit.

DE Das Anweisungsblatt des Produkts zu Rate ziehen.

NL Raadpleeg het instructieblad van het product.

ES Consulte la hoja de instrucciones del producto.

DA Se produktvejledningen.

NO Se anvisningene for produktet.

SV Se produktens instruktionsblad.

RU Смотреть прилагающейся инструкции к изделию

ZH 请参考产品说明书。



IT In caso di danneggiamento del cavo flessibile esterno, questo deve essere sostituito dal costruttore, o dal suo servizio di assistenza, o da personale qualificato equivalente, al fine di evitare pericoli.

EN Should the outer flexible cable be somehow damaged, the latter should be replaced by the manufacturer, or by the corresponding service centre, or by an appropriate and qualified member of staff in order to avoid all risk of danger.

FR Si le câble flexible extérieur est abîmé, faites-le remplacer par le fabricant, par son service après-vente ou par un professionnel du secteur agréé afin d'éviter tout danger.

DE Sollte das äußere Kabel beschädigt sein, so muss es aus Sicherheitsgründen vom Hersteller, dessen Kundendienst oder von dazu autorisiertem Personal ausgewechselt werden.

NL Mocht de externe flexibele slang beschadigd worden, dan moet deze worden vervangen door de fabrikant of door een bevoegde installateur, zodat eventueel gevaar vermeden wordt.

ES En caso de daños el cable flexible externo debe substituirse por el fabricante, su servicio de asistencia o personal calificado equivalente para evitar peligros.

DA Hvis den yderste ledning beskadiges, skal den udskiftes af producenten eller et autoriseret teknisk servicecenter, eller af kvalificerede fagfolk, så man undgår farlige situationer.

NO Hvis ytre fleksible kabel skulle bli skadet, skal denne skiftes ut av produsenten eller tilsvarende servicecenter eller av en egnet og kvalifisert fagperson for å unngå farerisiko.

SV Om den yttre kabeln skadas ska den bytas ut av tillverkaren, av dess auktoriserade verkstad eller av likvärdig kvalificerad personal för att undvika alla typer av risker.

RU В случае повреждения внешнего гибкого кабеля во избежание риска поручите его замену производителю, уполномоченному сервису или квалифицированному электрику.

ZH 如果外部软缆损坏, 须由生产商、对应服务中心或能胜任和资深的员工更换新的电缆, 以避免任何可能的危险。

+ art. X188

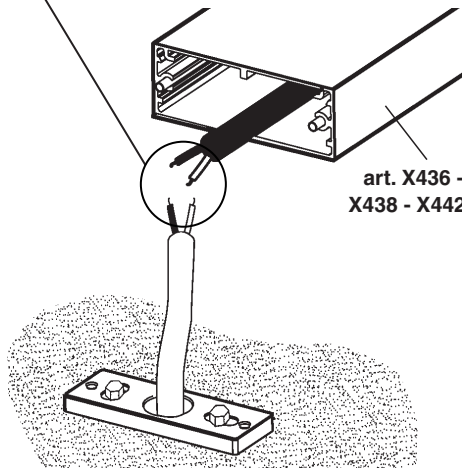
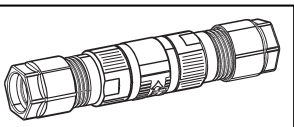

art. X436 - X440
 X438 - X442 - X445

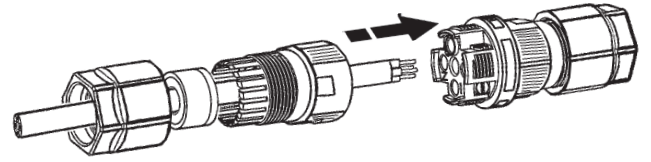

1,5 - 2 Nm

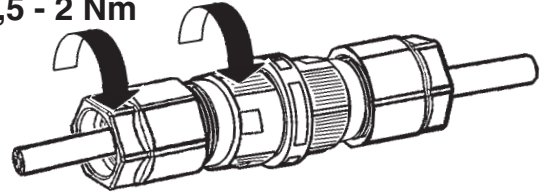

MAX 4 mm²

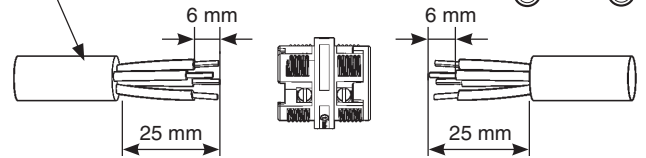

D (mm)		
1,5 ÷ 4,5 mm		
2 ÷ 4,5 mm		
1,5 ÷ 2,5 mm		
5 ÷ 7 mm		
4 ÷ 7 mm		
2 ÷ 3,5 mm		
1,5 ÷ 2,5 mm		
6 ÷ 7 mm		
7 ÷ 9 mm		
9 ÷ 12 mm		

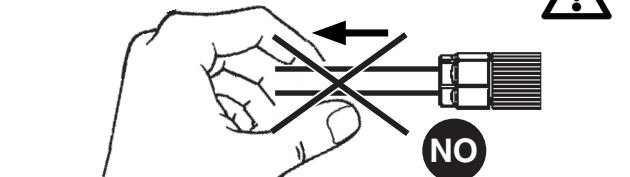
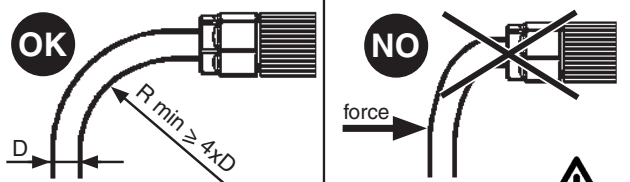

+ art. 9581

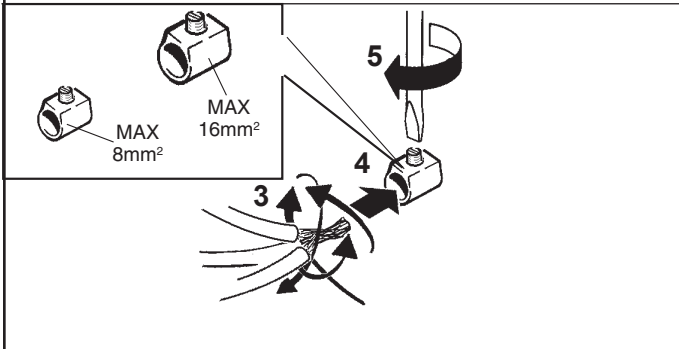
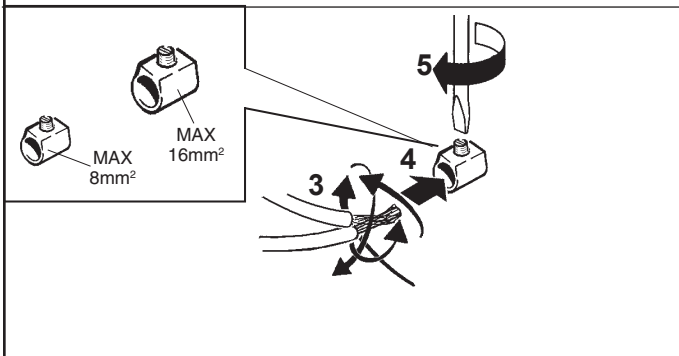
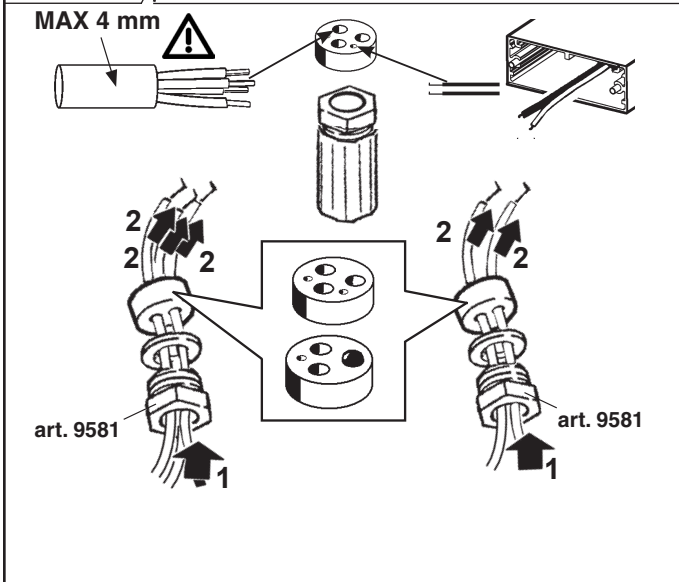
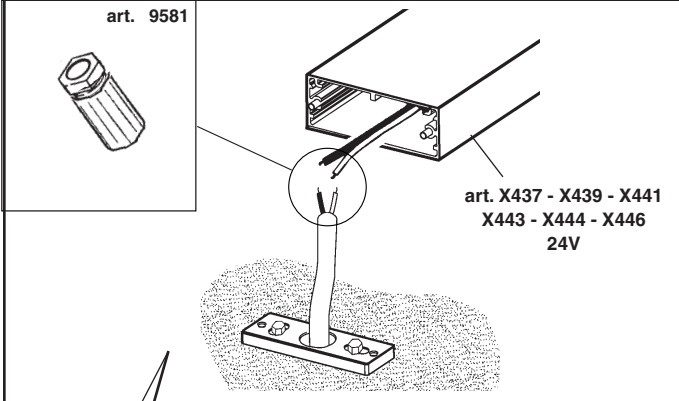

IT N.B.: Verificare manualmente la tenuta dei cavi nel morsetto.
 EN N.B.: Manually check the tightness of the cables in the terminal board.
 FR N.B.: Veuillez vérifier manuellement la tenue des fils dans la borne.
 DE NB: Der Halt der Drähte in der Klemme ist von Hand zu prüfen.
 NL N.B.: Verifieer handmatig of de kabels goed in de klemmenstrook vastzitten.
 ES N.B.: Verificar manualmente la fijación de los cables en el terminal.
 DA N.B.: Kontroller, at ledningerne i klemmen sidder ordentligt fast.
 NO N.B.: Kontroller tettheten til kablene i terminalkortet manuelt.
 SV OBS! Kontrollera för hand att kablarna sitter ordentligt fast i klämman.
 RU ПРИМЕЧАНИЕ: Проверьте вручную прочность соединения проводов к клеммам.
 ZH 注意：手动检查接线排电缆的牢固性。

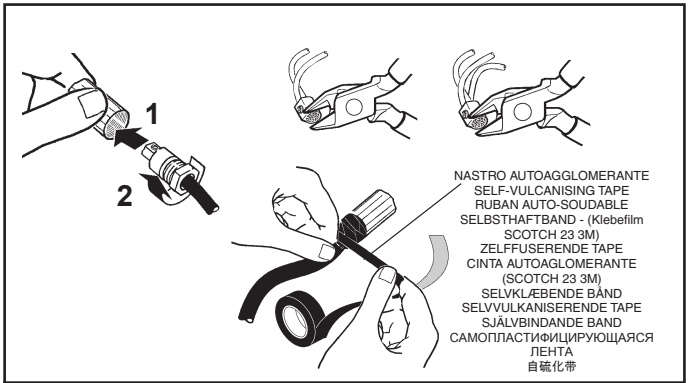

art. X188 + 9581

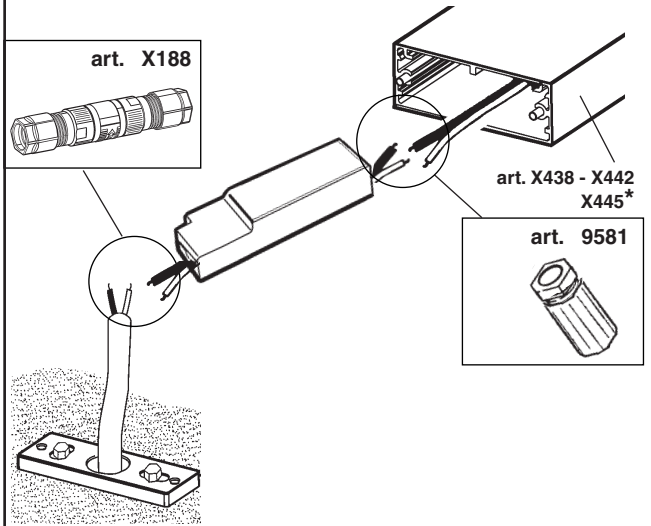

*
 IT "Protezione IP aggiuntiva per alimentatore non necessaria"
 EN "Extra IP protection for power supply not required"
 FR « Protection IP supplémentaire pour driver non nécessaire »
 DE "Zusätzlicher IP-Schutz für Versorgungseinheit nicht notwendig"
 NL "Extra IP-bescherming voor VSA niet nodig"
 ES "Protección IP complementaria para el alimentador innecesaria"
 DA "Ekstra IP-beskyttelse til forsyningsenhed, ikke nødvendig"
 NO "Ekstra IP-beskyttelse for strømforsyningen, ikke obligatorisk"
 SV "Extra IP-skydd för strömförsörjning, krävs ej".
 RU "Дополнительная защита IP для источника питания не требуется"
 ZH "无需额外的电源IP等级保护"

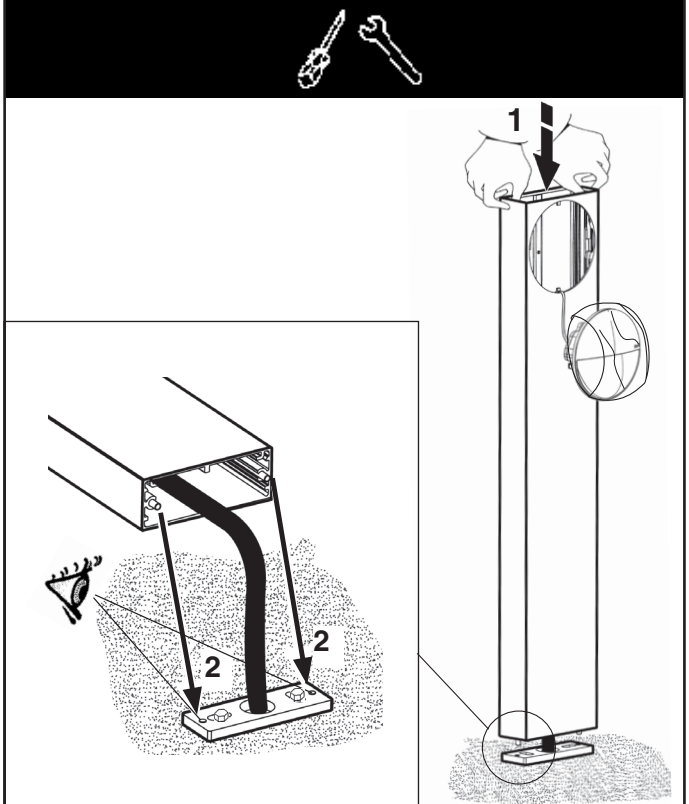

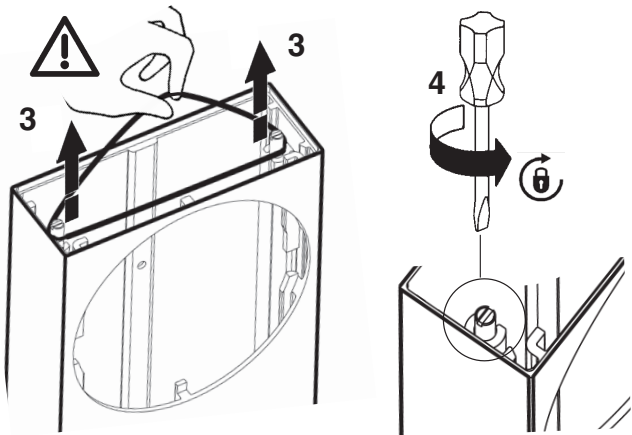

IT Prima di utilizzare il prodotto asportare gli elastici.

EN Remove the elastic bands before using the product.

FR Enlevez les élastiques avant d'utiliser le produit.

DE Bevor Sie das Produkt verwenden, entfernen Sie die Gummis.

NL Voordat u het product gaat gebruiken moeten de elastieken verwijderd worden.

ES Remover los elásticos antes de utilizar el producto.

DA Fjern elastikbåndene inden produktet tages i brug.

NO Fjern de elastiske båndene før bruk av produktet.

SV Ta bort gummisnoddarna innan utrustningen används.

RU Перед началом эксплуатации прибора снимите с него резинки.

ZH 在使用产品之前先取下弹性木梢。

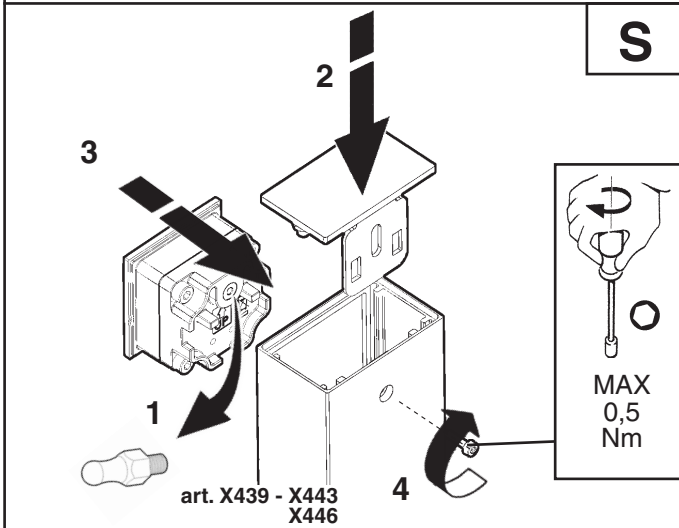

art. X439 - X443
X446

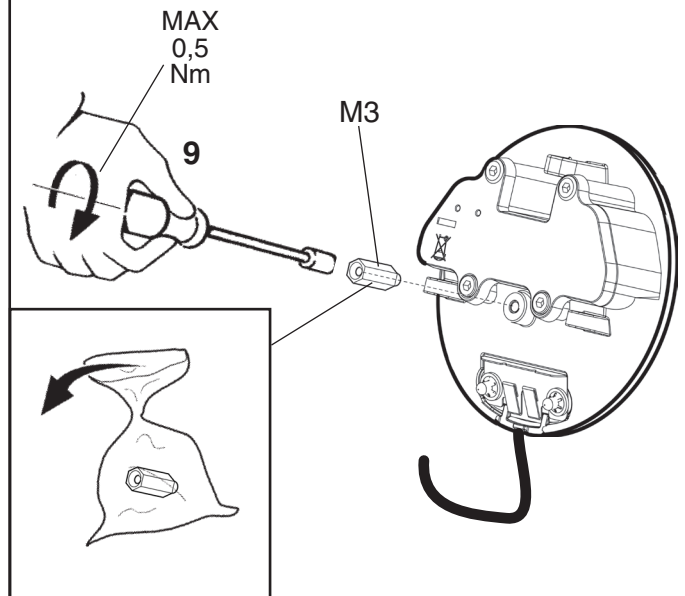
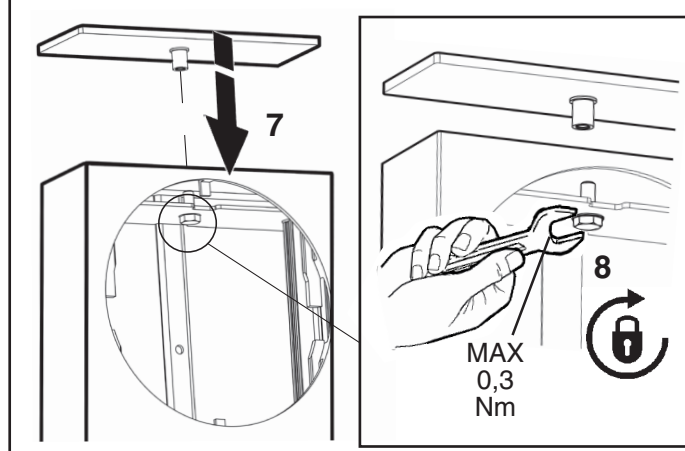
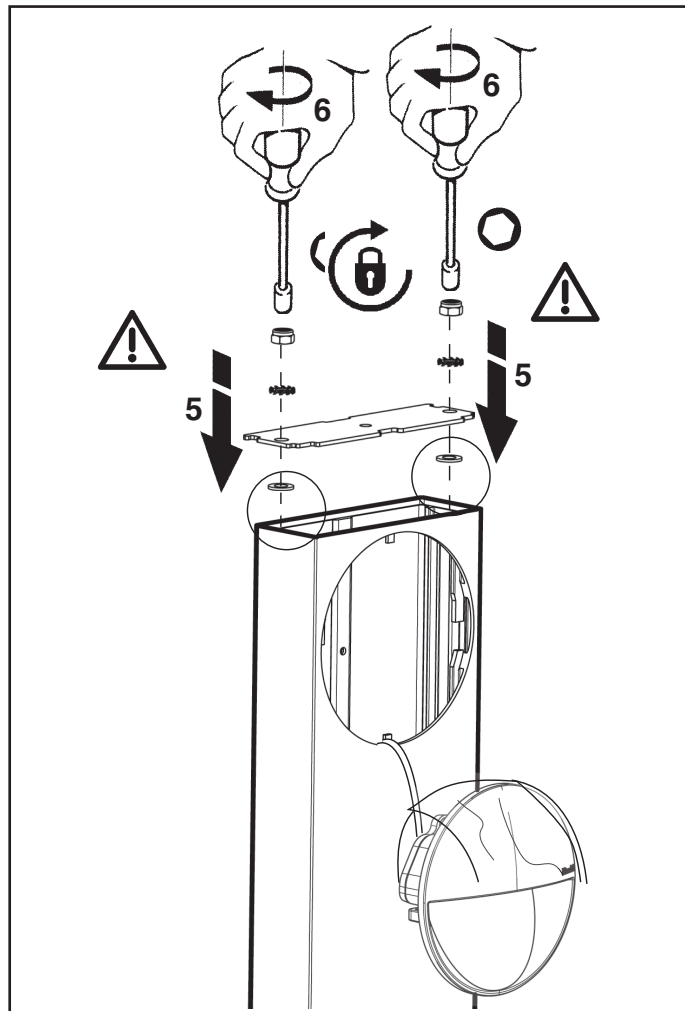
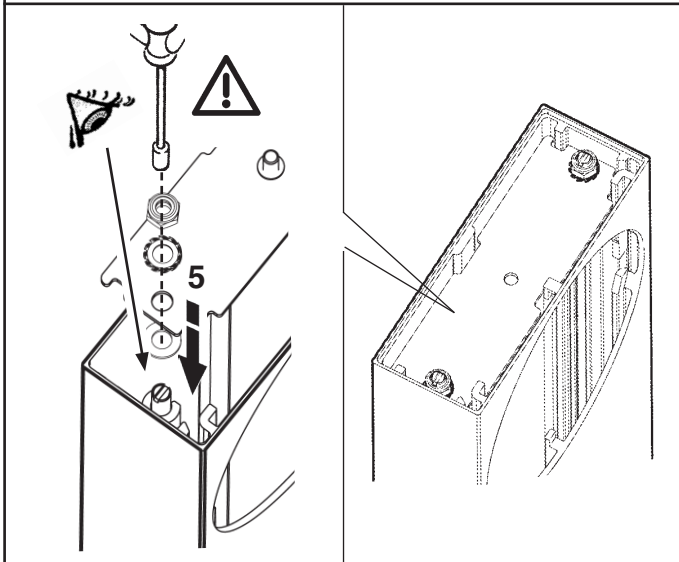
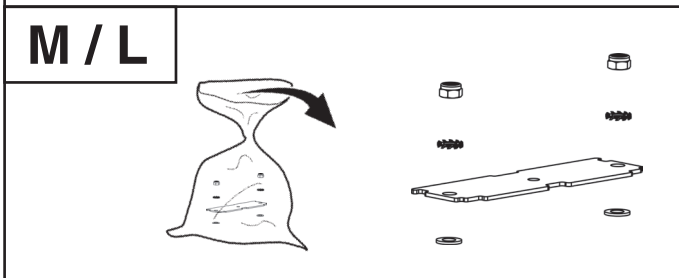



M 24V

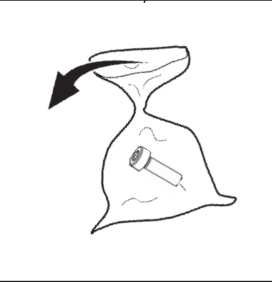
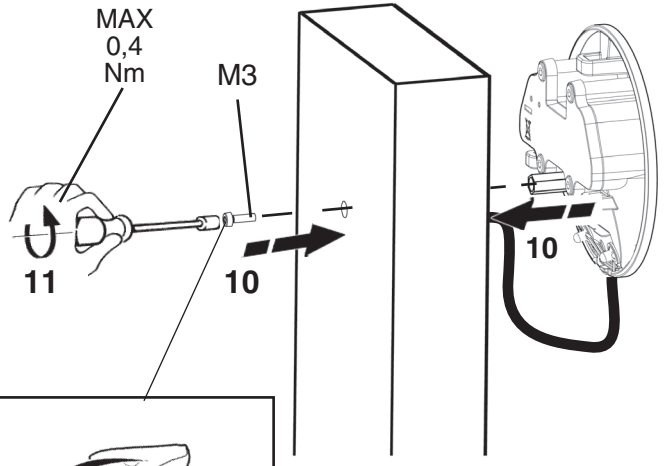

L 230V

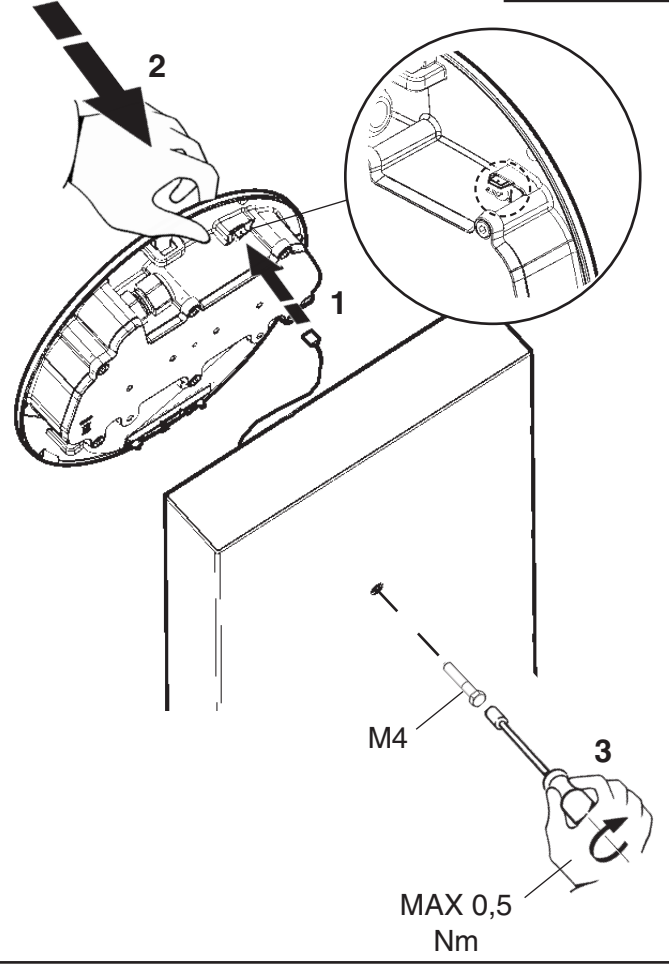

iGuzzini

WALKY

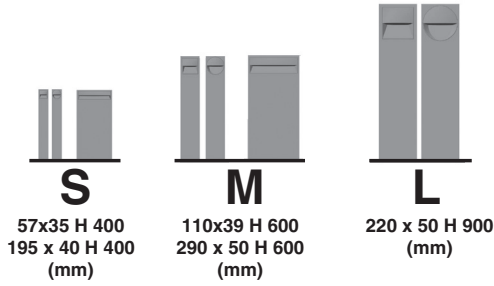

تحذير:

AR لا يمكن ضمان سلامة هذا الجهاز إلا إذا التزمت بهذه التعليمات، يجب حفظها في مكان آمن.

IT ATTENZIONE:

LA SICUREZZA DELL'APPARECCHIO E' GARANTITA SOLO CON L'USO APPROPRIATO DELLE SEGUENTI ISTRUZIONI; PERTANTO E' NECESSARIO CONSERVARLE.

EN WARNING:

THE SAFETY OF THIS FIXTURE IS GUARANTEED ONLY IF YOU COMPLY WITH THESE INSTRUCTIONS; REMEMBER TO CONSERVE IN A SAFE PLACE.

ES ATENCION:

LA SEGURIDAD DEL APARATO SE GARANTIZA SOLO CUMPLIENDO CUIDADOSAMENTE LAS SIGUIENTES INSTRUCCIONES; POR ELLO, ES NECESARIO CONSERVARLAS.

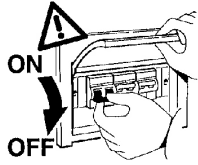

AR ملاحظة: ملاحظة: أثناء تركيب نظام . يجب التقيد بحرص بالنظم السائدة المتعلقة بالشبكة الكهربائية.

IT N.B.: DURANTE L'INSTALLAZIONE DEL SISTEMA RISPETTARE SCRUPolosAMENTE LE NORME IMPIANTISTICHE VIGENTI.

EN N.B.: WHEN INSTALLING THE SYSTEM STRICTLY COMPLY WITH ALL REGULATIONS ON INSTALLATION IN FORCE.

ES N.B.: DURANTE LA INSTALACION DEL SISTEMA RESPETAR ESCRUPolosAMENTE LAS NORMAS DE INSTALACION VIGENTES.

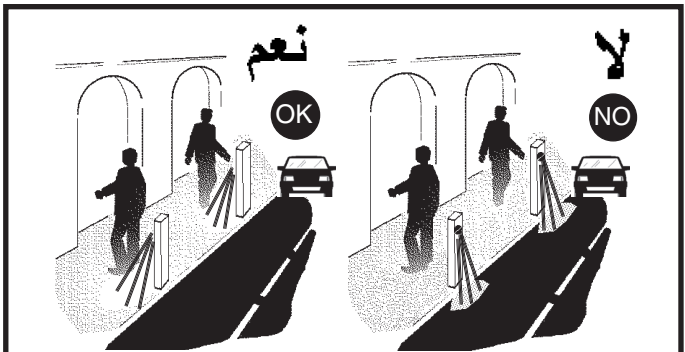

AR مواضع التركيب المختلفة عن المواضع المبينة غير مسموح بها.

IT Posizioni d'installazione diverse da quelle indicate non sono consentite.

EN Installation positions different to those indicated are not allowed.

ES No se permiten posiciones de instalacion diferentes de las indicadas.

Size	Art.	V	A mm ملم	B mm ملم	H mm ملم	Art.	Art.
L	X436	230V	220	50	900	✗	X447
L	X440	230V	220	50	900	✗	X447
M	X437	24V	110	39	600	✗	X448
M	X438	24V	110	39	600	✓	X448
M	X441	24V	110	39	600	✗	X448
M	X442	24V	110	39	600	✓	X448
S	X439	24V	57	35	400	✗	X449
S	X443	24V	57	35	400	✗	X449
M	X444	24V	290	50	600	✗	X450
M	X445	24V	290	50	600	✓	X450
S	X446	24V	195	40	400	✗	X451

AR ملاحظة: عند تركيب الجهاز يجب مراعاة عدم دفن القاعدة أو وضعها في الأماكن المعرضة للغمر بالمياه.

IT N.B.: Installando l'apparecchio, evitare che la base venga interrata o posizionata in punti soggetti al ristagno dell'acqua.

EN N.B.: Whilst installing the appliance, avoid concealing its base or placing it in areas which are susceptible to damp.

ES NOTA: Al instalar el aparato, evite que la base se entierre o se coloque en puntos donde se pueda estancar el agua.

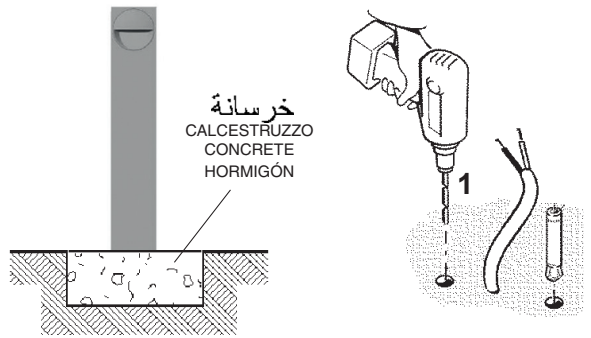

AR عند التثبيت ينصح باستخدام مسامير كبيرة نوع FZA- I- M8/M5 أو ما شابهها ومن صنع شركات أخرى.

PER IL FISSAGGIO SI CONSIGLIA DI UTILIZZARE TASSELLI PER ANCORAGGI PESANTI TIPO FZA- I- M8/M5 FISCHER, O SIMILARI ANCHE DI ALTRI COSTRUTTORI.

FOR FIXING USE HEAVY DUTY PLUGS, SUCH AS FZA- I- M8/M5 FISCHER OR SIMILAR, INCLUDING FROM OTHER MANUFACTURERS.

PARA LA FIJACION SE RECOMIENDA UTILIZAR TACOS PARA ANCLAJES DE GRAN RESISTENCIA, TIPO FZA- I- M8/M5 FISCHER, O SIMILARES, INCLUSO DE OTROS FABRICANTES.

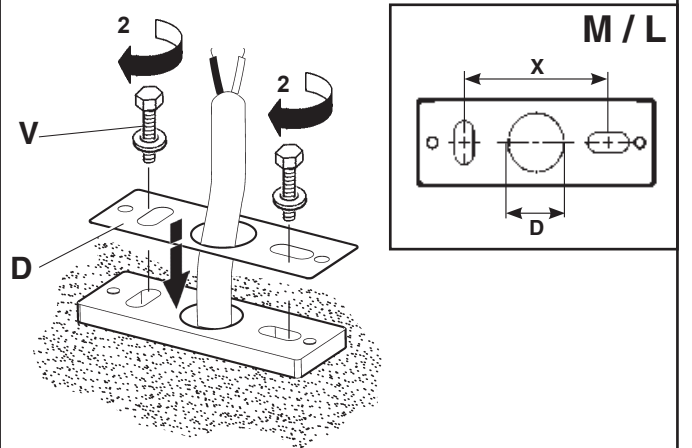

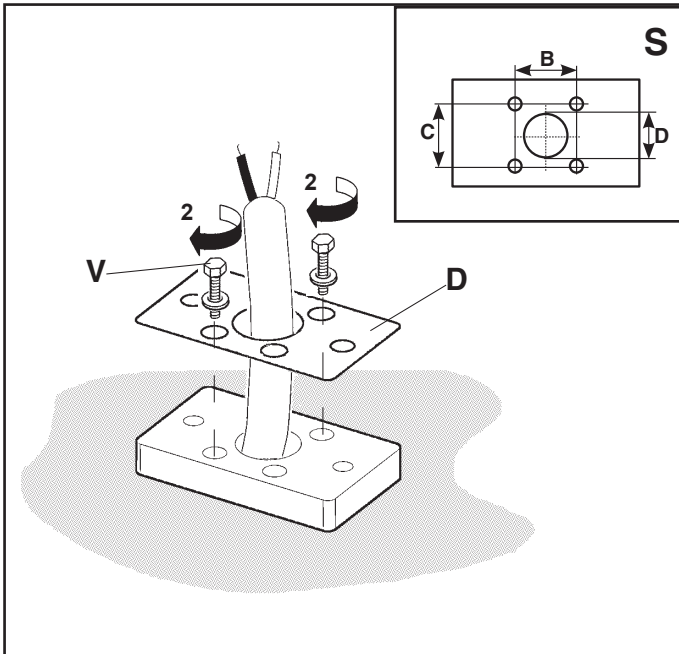

ART.	X (mm)	B (mm)	C (mm)	D (mm)	V (mm)
X436 - X440	140	/	/	25	M8
X437 - X438 - X441 - X442	65				
X444 - X445	200				
X446	120				
X439 - X443	/	16	20	14	M5

+ art. X447 - X448 - X449 - X450 - X451

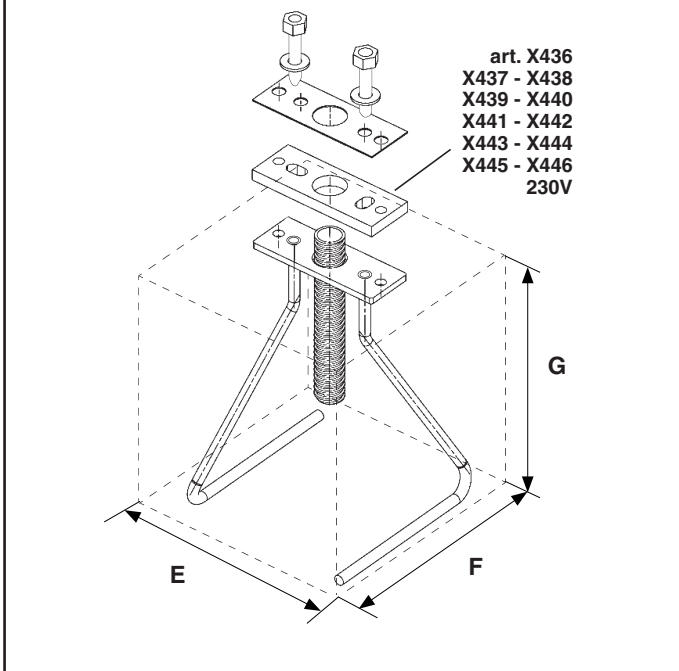
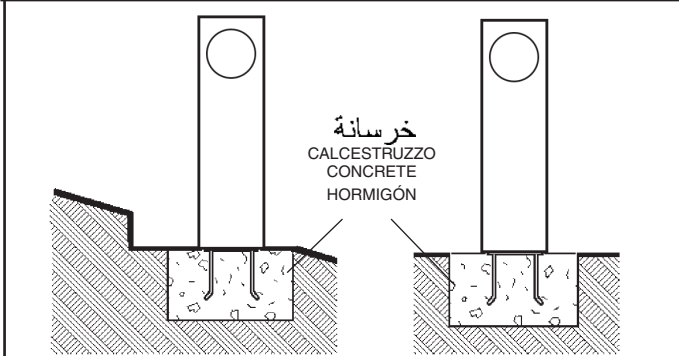

art. X436
X437 - X438
X439 - X440
X441 - X442
X443 - X444
X445 - X446
230V

ART.	E (mm)	F (mm)	G (mm)
X436 - X440	350	350	350
X437 - X438 - X441 - X442	300	300	300
X444 - X445	400	300	300
X446	300	250	250
X439 - X443	250	250	250

AR فقط وقد تم قياسها مع الأخذ في الاعتبار بأن الأرضية تتحمل ضغط 1,0 بار (1,0 كجم /سم²)
ملحوظة هامة: تعد أبعاد القاعدة المذكورة بغرض إرشادي

IT N.B.: Le dimensioni del Plinto sono fornite a titolo indicativo, sono state calcolate considerando un terreno con pressione ammissibile di 1,0bar (1,0 kg /cm²)

EN N.B.: The dimensions of the plinth are purely indicative and were calculated taking into account a surface with an allowable pressure of 1.0 bar (1.0 kg/cm²)

ES NOTA: Las medidas de Plinto son sólo indicativas, han sido calculadas considerando un terreno con presión admisible de 1,0bar (1,0 kg /cm²)

يجب حماية الجزء المطلي.
Proteggere la parte verniciata.
Protect the painted part
Proteger la parte barnizada

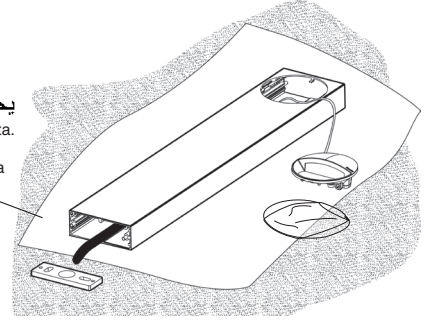

AR يُرجى مراجعة ورقة التعليمات الخاصة بالمنتج.

IT Consultare il foglio istruzioni del prodotto.

EN Refer to the product instruction sheet.

ES Consulte la hoja de instrucciones del producto.



AR في حال تلف الكبل الخارجي المرن، يجب تغييره من قبل المصنع أو من قبل مركز الخدمة المخول أو من قبل أحد أعضاء الطاقم الملائمين والمؤهلين وذلك لتعاشي إلحاق أي خطر.

IT In caso di danneggiamento del cavo flessibile esterno, questo deve essere sostituito dal costruttore, o dal suo servizio di assistenza, o da personale qualificato equivalente, al fine di evitare pericoli.

EN Should the outer flexible cable be somehow damage, the latter should be replaced by the manufacturer, or by the corresponding service centre, or by an appropriate and qualified member of staff in order to avoid all risk of danger.

ES En caso de daños el cable flexible externo debe substituirse por el fabricante, su servicio de asistencia o personal calificado equivalente para evitar peligros.

+ art. X188

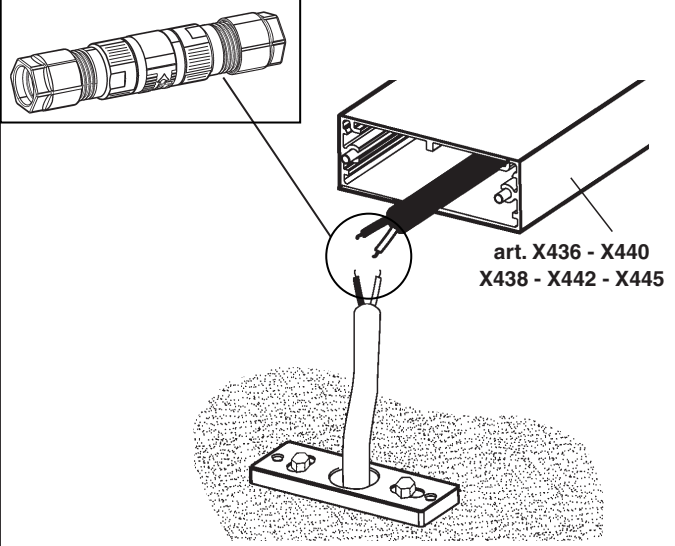

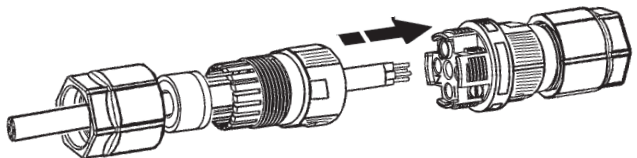

1,5 - 2 Nm

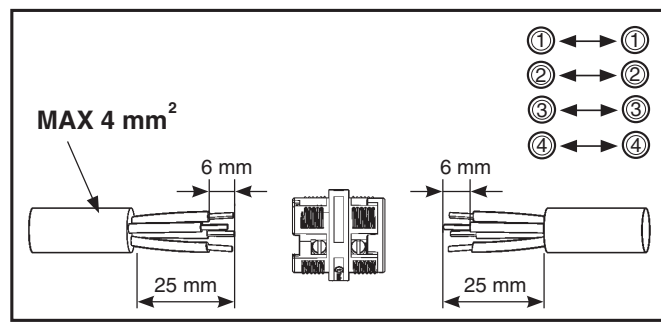
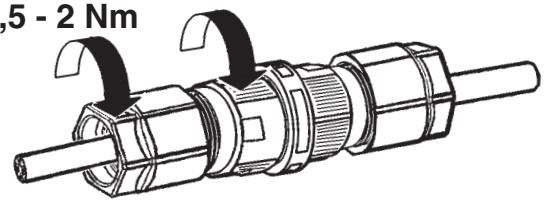

D (mm)	Cable Cross-sections	
1,5 ÷ 4,5 mm		
2 ÷ 4,5 mm		
1,5 ÷ 2,5 mm		+
5 ÷ 7 mm		
4 ÷ 7 mm		+
2 ÷ 3,5 mm		
1,5 ÷ 2,5 mm		+
6 ÷ 7 mm		+ +
7 ÷ 9 mm		+
9 ÷ 12 mm		+

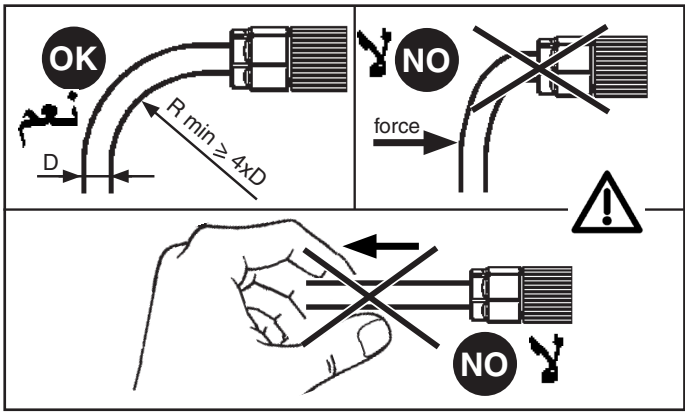

+ art. 9581

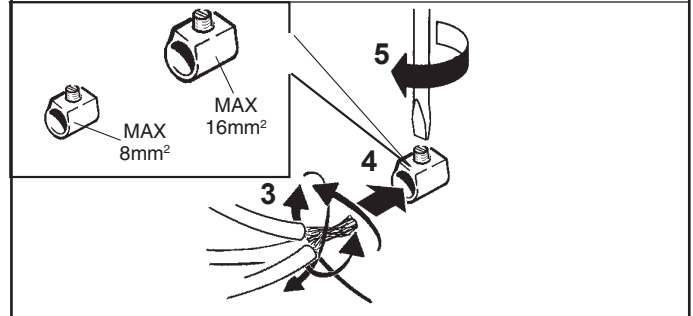
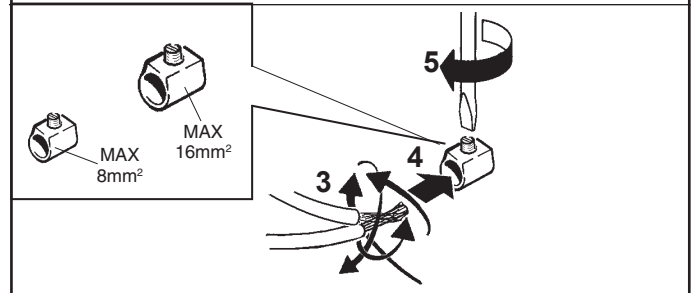
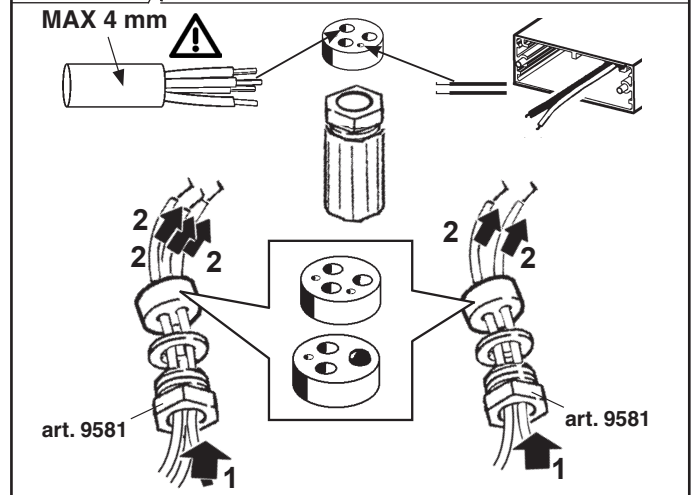
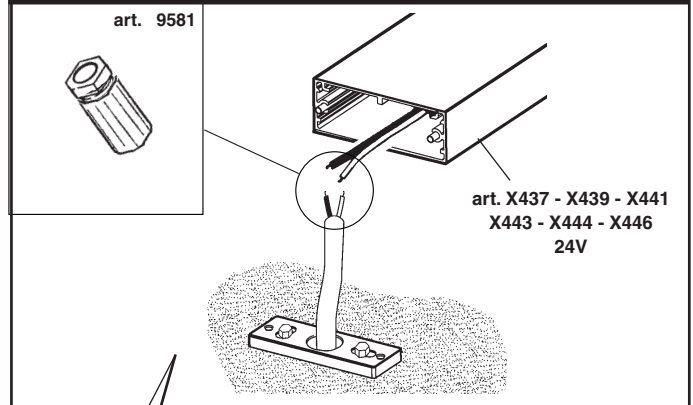

AR تنبيه: تحقق يدويا من مناعة الكبلات داخل طرف التوصيل.

IT N.B.: Verificare manualmente la tenuta dei cavi nel morsetto.
 EN N.B.: Manually check the tightness of the cables in the terminal board.
 ES N.B.: Verificar manualmente la fijación de los cables en el terminal.

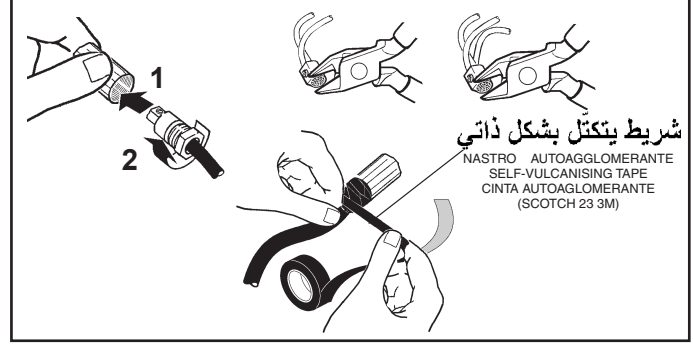

art. X188 + 9581

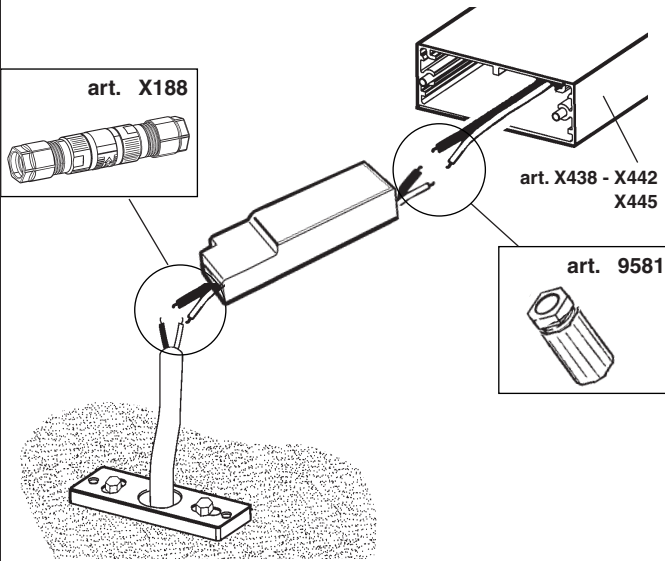

الحماية الإضافية IP لمزود الطاقة غير ضرورية"

IT "Protezione IP aggiuntiva per alimentatore non necessaria"
 EN "Extra IP protection for power supply not required"
 FR « Protection IP supplémentaire pour driver non nécessaire »
 DE "Zusätzlicher IP-Schutz für Versorgungseinheit nicht notwendig"
 NL "Extra IP-bescherming voor VSA niet nodig"
 ES "Protección IP complementaria para el alimentador innecesaria"

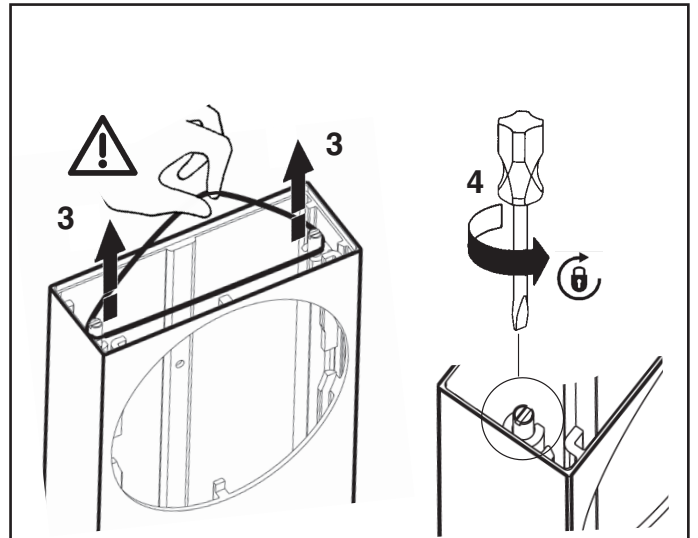

AR بعد الأحزمة المرنة قبل استخدام المنتج.
 IT Prima di utilizzare il prodotto asportare gli elastici.
 EN Remove the elastic bands before using the product.
 ES Remover los elásticos antes de utilizar el producto.

