

LIGHT SHED 60 pendant accessories

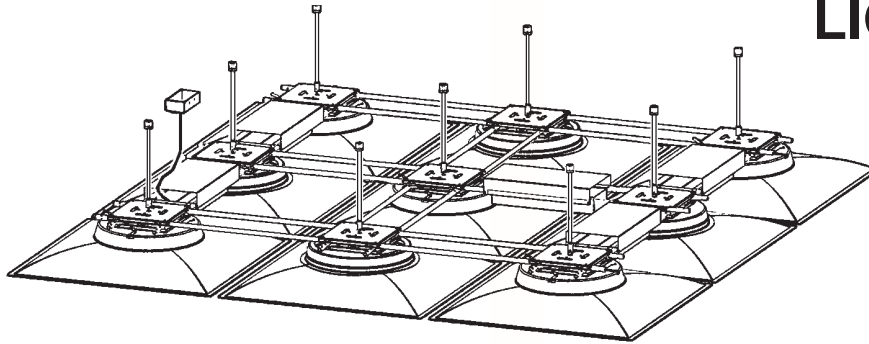

IT **Attenzione:**

La sicurezza dell'apparecchio e' garantita solo con l'uso appropriato delle seguenti istruzioni; pertanto e' necessario conservarle.

EN **Warning:**

The safety of this fixture is guaranteed only if you comply with these instructions; remember to conserve in a safe place.

FR **Attention:**

La sécurité de l'appareil n'est garantie qu'en cas d'utilisation correcte des instructions suivantes; il faut par conséquent les conserver.

DE **Achtung:**

Die Sicherheit des Gerätes wird nur durch sachgemäße Befolgung nachstehender Anweisungen gewährleistet; ihre Aufbewahrung ist deshalb sehr wichtig.

NL **Opgelet:**

De veiligheid van dit toestel is slechts dan gegarandeerd als indien de volgende instructies strikt worden toegepast: daarom moet men ze ook bewaren.

ES **Atencion:**

La seguridad del aparato se garantiza solo cumpliendo cuidadosamente las siguientes instrucciones; por ello, es necesario conservarlas.

DA **Bemærk:**

Sikkerheden ved brug af armaturet kan kun garanteres, hvis disse anvisninger følges; sørg derfor for at gemme dem.

NO **Advarsel:**

Sikkerheten til dette apparatet garanteres kun hvis du overholder disse instruksjonene; husk å oppbevare dem på et trygt sted.

SV **Observera:**

Utrustningens säkerhet kan endast garanteras om dessa anvisningar respekteras i detalj. Spara därför dessa anvisningar för framtida konsultation.

RU **Внимание:**

Мы гарантируем безопасную эксплуатацию изделия только при соблюдении следующих инструкций; с этой целью необходимо сохранить данную брошюру.

ZH **警告:**

为确保该装置安全, 请遵守操作指示; 并于安全场所放置。

AR **تحذير:** لا يمكن ضمان سلامة هذا الجهاز إلا إذا التزمت بهذه التعليمات. يجب حفظها في مكان آمن.

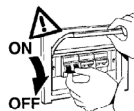

IT N.B.: Durante l'installazione del sistema rispettare scrupolosamente le norme impiantistiche vigenti.

EN N.B.: When installing the system, strictly comply with all regulations on installation in force.

FR N.B.: Lors de l'installation du système veuillez respecter rigoureusement les normes en vigueur en la matière.

DE N.B.: Beachten sie bei der installation des systems gewissenhaft die gültigen bestimmungen bezüglich der anlagentechnik.

NL N.B.: Bij het installeren van het systeem moet u de geldende installatienormen strikt naleven.

ES N.B.: Durante la instalación del sistema respetar e scrupulosamente las normas de instalación vigentes.

DA N.B.: Under installation af systemet skal man nøje overholde de gældende regler for disse anlæg.

NO N.B.: Ved installasjon av systemet skal alle forskrifter om installasjon som gjelder følges strengt.

SV OBS.: Under installationen av systemet ska installationsföreskrifterna respekteras i detalj.

RU примечание: в процессе монтажа системы строго соблюдайте национальные действующие нормативы по электропроводке.

ZH 注意: 在安装系统时请遵守设备的安装规定。

AR ملاحظة: أثناء تركيب النظام يجب التقيد بحرص بالنظم السائدة المتعلقة بالشبكة الكهربائية.

IT Per le posizioni di installazione, attenersi a quelle illustrate, eventualmente contattare la iGuzzini.

EN All installation positions must comply with those illustrated. In the event of any doubt, contact iGuzzini.

FR Pour les positions d'installation, se conformer aux positions illustrées; contacter la société iGuzzini en cas de nécessité.

DE Für die Einbaupositionen die Abbildungen beachten. Eventuell iGuzzini kontaktieren.

NL Houid u voor de installatieposities aan degene die zijn weergegeven. Neem eventueel contact op met iGuzzini.

ES Respetar las posiciones de instalación ilustradas y, en caso de duda, contactar con iGuzzini.

DA For installationspositioner skal man holde sig til de viste, og eventuelt kontakte iGuzzini.

NO For installasjonsplasseringene henviser vi til illustrasjonene, eller ta eventuelt kontakt med iGuzzini.

SV Följ de angivna positionerna för installationen. Kontakta vid behov iGuzzini.

RU При выборе положения для монтажа следует обратиться к проиллюстрированному либо обратиться в компанию iGuzzini.

ZH 安装位置请参考图示, 必要时也可联系iGuzzini.

AR في ما يتعلق بأوضاع التركيب، التزم بما هو موضح ومحدد، إذا دعت الضرورة اتصل بـ iGuzzini.

AR

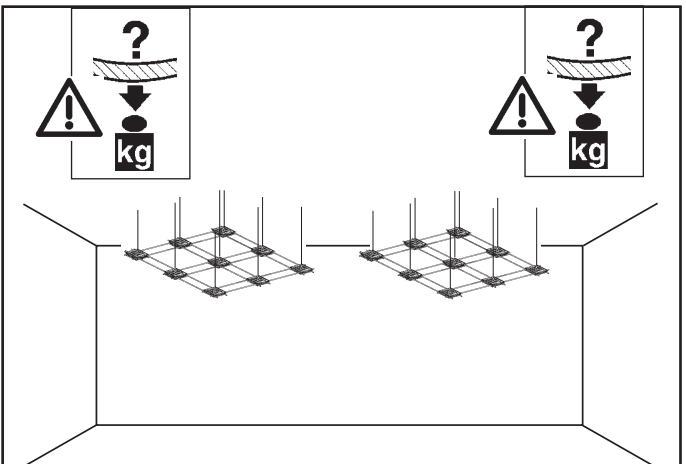

IT N.B.: E' responsabilità dell'utente verificare la resistenza del controsoffitto, in funzione del peso degli apparecchi installati.

EN N.B.: It is the user's responsibility to check the strength of the false ceiling with respect to the weight of the fixtures installed.

FR N.B.: Il appartient à l'utilisateur de vérifier la résistance du faux plafond en fonction du poids des appareils installés.

DE N.B.: Es obliegt dem Verbraucher sicherzustellen, daß die Deckenverkleidung das Gewicht der Einbauleuchte aufnehmen kann.

NL N.B.: Het is de verantwoordelijkheid van de koper zich ervan te verzekeren dat het verlaagde plafond stevig genoeg is voor het dragen van het gewicht van de geïnstalleerde apparaten.

ES NOTA: Corresponde al usuario efectuar las pruebas en el falso techo, en función del peso de los aparatos instalados.

DA N.B.: Det er brugerens ansvar, at kontrollere loftets modstandsdygtighed, ud fra de installerede apparaters vægt.

NO N.B.: Det er brukerens ansvar å kontrollere himlingens/takets motstandskraft, på grunnlag av de installerte apparatene vekt.

SV OBS! Det är användarens ansvar att kontrollera takets hållfasthet i förhållande till vikten på installerad utrustning.







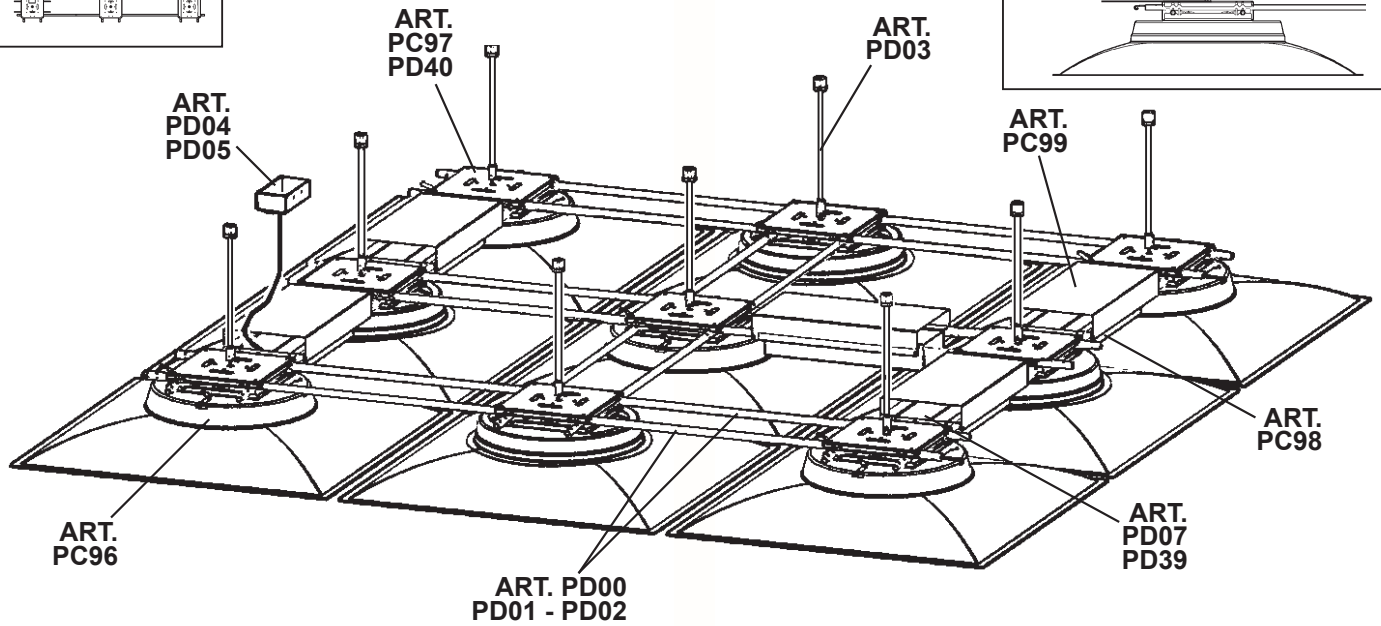
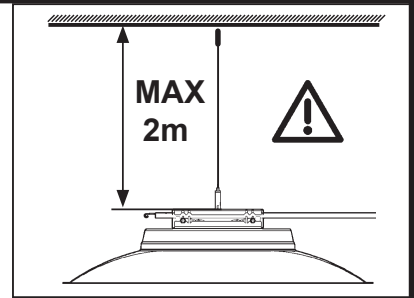
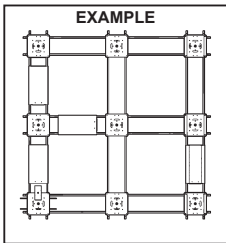

RU ПРИМЕЧАНИЕ: Пользователь должен проверить прочность фальш-потолка в соответствии с весом устанавливаемых в него приборов.

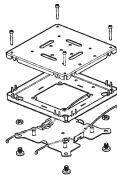
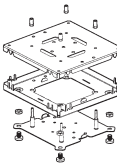
ZH 注意: 用户须根据安装装置的重量检查天花的强度。



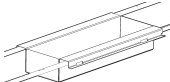

AR ملاحظة: يتحمل المستخدم مسؤولية التحقق من صلاية السقف ونظام التعليق بناء على وزن الأجهزة المركبة.

AR

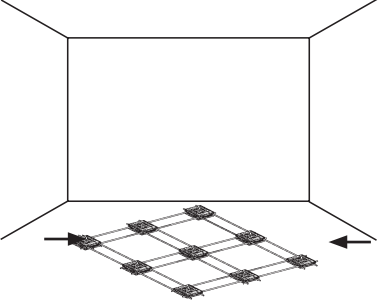

ART.	DESCRIPTION	
PC96	COVER	
PC97	PLATE - SPRING LOCKING (TOOL FREE)	
PD40	PLATE (WHIT TOOL)	
PD00 PD01 PD02	RODS	
PD03	PENDANT CABLE	
PD04	POWER BASE: ON-OFF	
PD05	POWER BASE: DALI - TW - EMERGENCY	
PD07	TERMINAL BLOCK DALI / Emergency / Tunable White	
PD39	TERMINAL BLOCK ON-OFF	
PC98	DRIVER BOX	
PC99	COVER DRIVER BOX	

INSTALLATION SEQUENCE RACCOMANDED

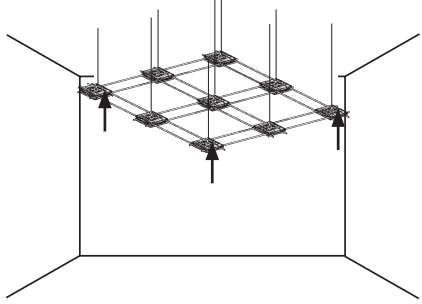
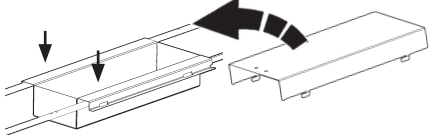
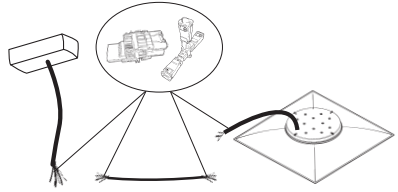
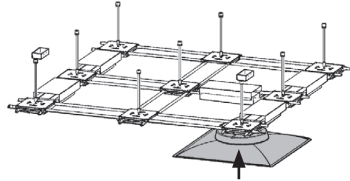
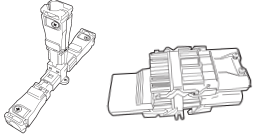
<p>1</p>	<p>IT-INSTALLAZIONE CAVO DI SOSPENSIONE EN-PENDANT CABLE INSTALLATION FR-INSTALLATION DU CÂBLE DE SUSPENSION DE-MONTAGE SEILPENDEL NL-INSTALLATIE KABEL HANGLAMP ES-INSTALACIÓN DEL CABLE DE SUSPENSIÓN DA-HÆNGEKABELINSTALLATION NO-INSTALLASJON MED HENGENDE KABEL SV-INSTALLERA DEN HÅNGANDE KABELN RU-МОНТАЖ ПОДВЕСНОГО КАБЕЛЯ ZH-悬垂电缆安装</p>	<p>ART. PD03</p> 
<p>2</p>	<p>IT-INSTALLAZIONE BASETTA DI ALIMENTAZIONE EN-POWER BASE INSTALLATION FR-INSTALLATION DE LA BASE D'ALIMENTATION DE-MONTAGE STROMQUELLE NL-INSTALLATIE VOEDINGSBASIS ES-INSTALACIÓN DE LA BASE DE ALIMENTACIÓN DA-STRØMBASEINSTALLATION NO-INSTALLASJON AV STRØMBASE SV-INSTALLERA STRÖMBASEN RU-УСТАНОВКА БАЗЫ ЭЛЕКТРОПИТАНИЯ ZH-电源底座安装</p>	<p>ART. PD04 PD05</p> 
<p>3</p>	<p>IT-ASSEMBLAGGIO STRUTTURA EN-STRUCTURE ASSEMBLY FR-ASSEMBLAGE DE LA STRUCTURE DE-ZUSAMMENBAU DER STRUKTUR NL-STRUCTUUR ES-ENSAMBLAJE DE LA ESTRUCTURA DA-STRUKTURSAMLING NO-MONTERING AV STRUKTUR SV-MONTERA STRUKTUREN RU-МОНТАЖ КОНСТРУКЦИИ ZH-结构组装</p>	<p>RODS ART. PD00 PD01 PD02</p> <p>PLATES ART. PC97 PD40</p> <p>PENDANT CABLE ART. PD03</p> 
<p>4</p>	<p>IT-SOLLEVAMENTO E INSTALLAZIONE DELLA STRUTTURA EN-RAISING UP AND STRUCTURE INSTALLATION FR-ÉLEVATION ET INSTALLATION DE LA STRUCTURE DE-AUFRICHTEN UND MONTAGE DER STRUKTUR NL-OPRICHTEN EN INSTALLATIE STRUCTUUR ES-ELEVACIÓN E INSTALACIÓN DE LA ESTRUCTURA DA-OPREJSE- OG STRUKTURINSTALLATION NO-OPPRETNING OG INSTALLASJON AV STRUKTUR SV-STALLA UPP OCH INSTALLERA STRUKTUREN RU-ПОДЪЕМ И УСТАНОВКА КОНСТРУКЦИИ ZH-提升和结构安装</p> <p>MIN 2: </p> <p>MAX 3X3: </p>	
<p>5</p>	<p>IT-POSIZIONAMENTO BOX EN-BOX POSITIONING FR-POSITIONNEMENT DU BOÎTIER DE-POSITIONIERUNG DER BOX NL-PLAATSING BOX ES-POSICIONAMIENTO DE LA CAJA DA-BOKSPLACERING NO-PLASSERING AV BOKS SV-POSITIONERA BOXEN RU-ПОЗИЦИОНИРОВАНИЕ КОРОБА ZH-盒子定位</p>	<p>BOX ART. PC98</p> <p>COVER ART. PC99</p> 
<p>6</p>	<p>IT-PREPARAZIONE DELL'IMPIANTO ELETTRICO EN-ELECTRICAL SYSTEM PREPARATION FR-PRÉPARATION DU SYSTÈME ÉLECTRIQUE DE-VORBEREITUNG DER ELEKTRISCHEN ANLAGE NL-VOORBEREIDING ELEKTRISCH SYSTEEM ES-PREPARACIÓN DEL SISTEMA ELÉCTRICO DA-KLARGØRING AF ELEKTRISK SYSTEM NO-FORBEREDELSE AV ELEKTRISK SYSTEM SV-FÖRBEREDA DET ELEKTRISKA SYSTEMET RU-ПОДГОТОВКА ЭЛЕКТРИЧЕСКОЙ СИСТЕМЫ ZH-电路系统准备</p>	<p>POWER BASE ART. PD04 PD05</p> <p>TERMINAL BLOCK ART. PD07 PD39</p> 
<p>7</p>	<p>IT-INSTALLAZIONE DEL PRODOTTO EN-PRODUCT INSTALLATION FR-INSTALLATION DU PRODUIT DE-PRODUKTINSTALLATION NL-INSTALLATIE PRODUCT ES-INSTALACIÓN DEL PRODUCTO DA-PRODUKTINSTALLATION NO-PRODUKTINSTALLASJON SV-INSTALLERA PRODUKTEN RU-УСТАНОВКА ИЗДЕЛИЯ ZH-产品安装</p>	<p>PLATES ART. PC97 PD40</p> <p>COVER ART. PC96</p> 
<p>8</p>	<p>IT-COLLEGAMENTO DEL PRODOTTO EN-PRODUCT CONNECTION FR-BRANCHEMENT DU PRODUIT DE-PRODUKTANSCHLUSS NL-AANSLUITING PRODUCT ES-CONEXIÓN DEL PRODUCTO DA-PRODUKTILSLUTNING NO-PRODUKTILKOBLING SV-ANSLUTA PRODUKTEN RU-ПОДКЛЮЧЕНИЕ ИЗДЕЛИЯ ZH-产品连接</p>	<p>TERMINAL BLOCK ART. PD07 PD39</p> 

ART. PD03

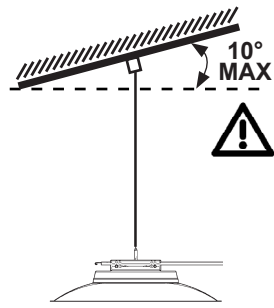
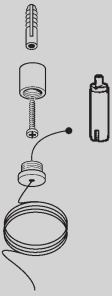

Y mm	X MAX mm
300	10
500	17
1000	35
1500	52
2000	70

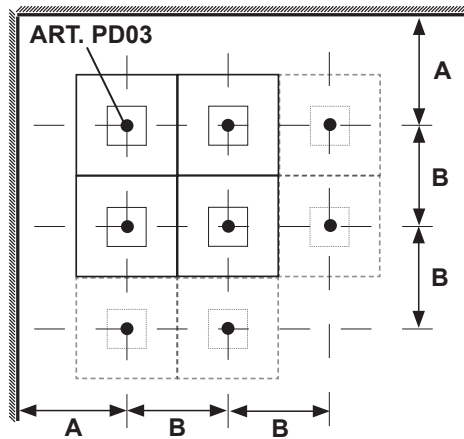
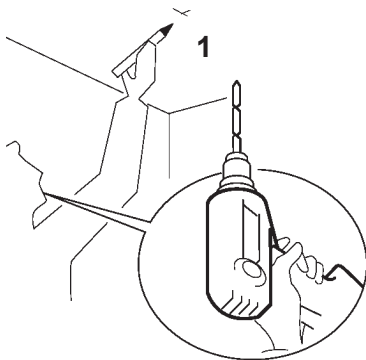
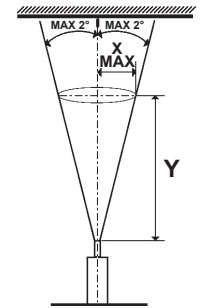

ART.	A MIN (mm)	B (mm)
596x596	460	620
621x621	460	645

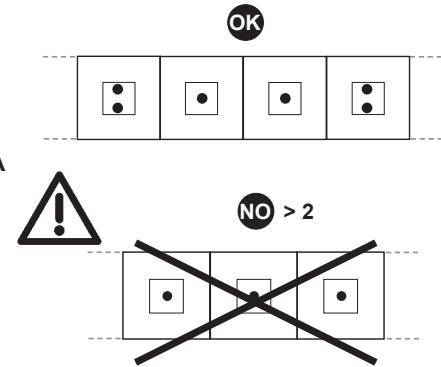
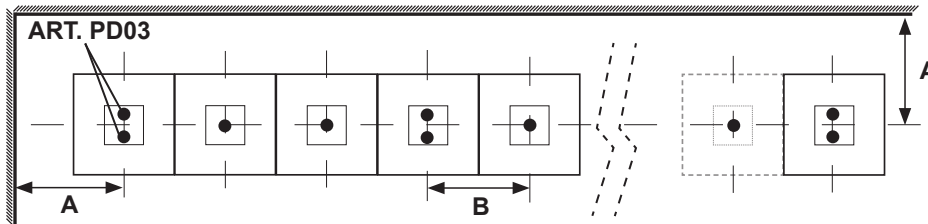

1X
ART. PD03

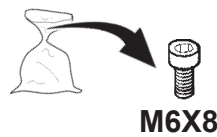
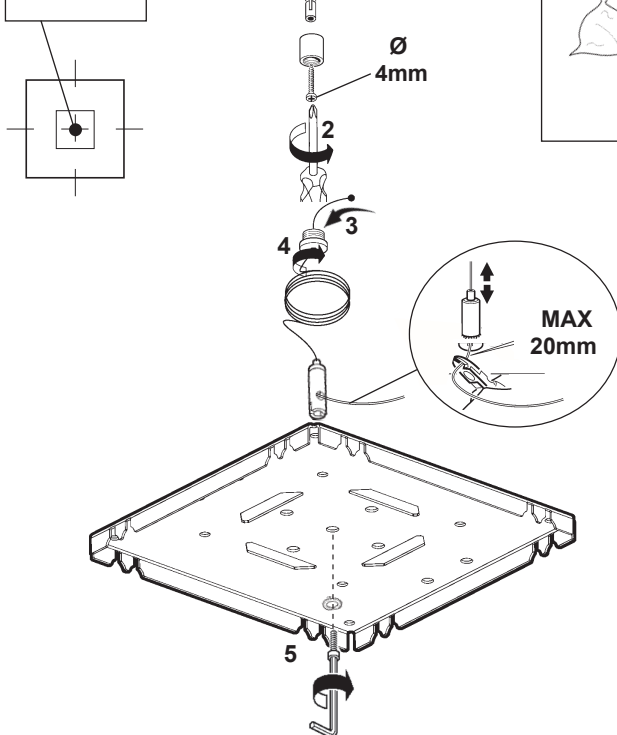

2X
ART. PD03

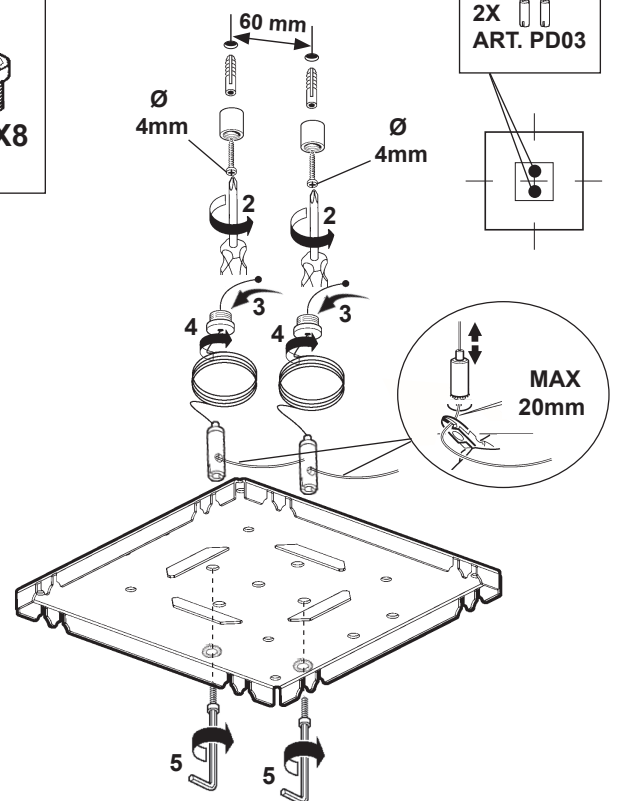

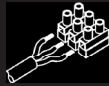

ART. PD04 PD05

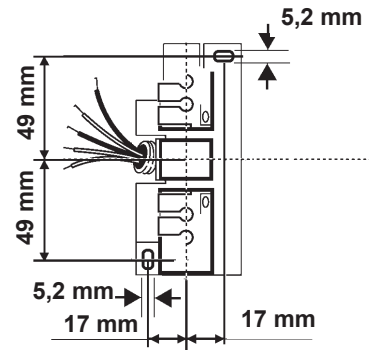
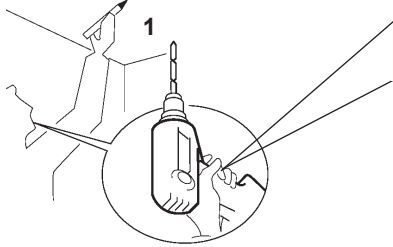
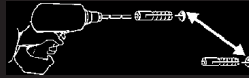
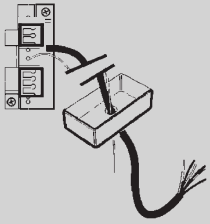

ART. PD04

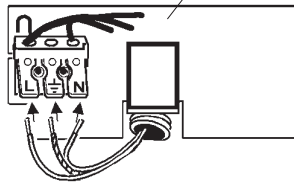

ART. PD05

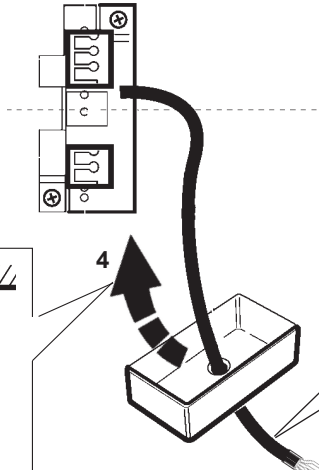
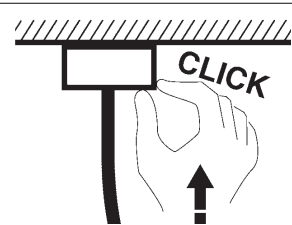
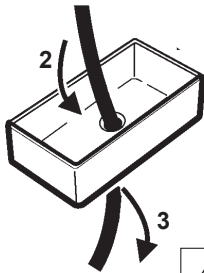
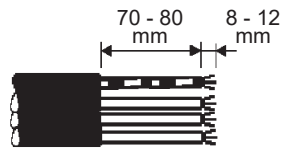
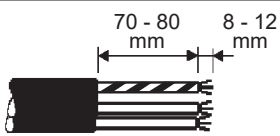
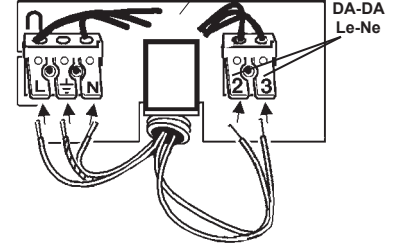

POWER BASE ART.

PD04
(ON-OFF)

PD05
(DALI / TW / EMERGENCY)

TERMINAL BLOCK ART.

➔ **PD39**

➔ **PD07**

MAX 9A

ART . PD07

ART . PD39

- IT** Nella progettazione dell'impianto illuminotecnico ed elettrico, determinare le correnti massime ammissibili, considerando i seguenti fattori:
- 9A: corrente nominale ammessa dalle morsettiere;
 - coefficiente di sicurezza per tenere conto delle sovratensioni e contemporaneità;
 - corrente nominale assorbita dai singoli art.
- EN** When planning the lighting and electrical system, determine the maximum permitted current, taking into account the following factors:
- 9A: the nominal current permitted by terminal blocks;
 - safety coefficient to allow for excess voltage and contemporaneity;
 - the nominal current absorbed by single art.
- FR** Lors de l'étude de projet de l'installation d'éclairage et de l'installation électrique, déterminer les courants maximaux admissibles en tenant compte des facteurs suivants :
- 9A: courant maximal admis par les borniers;
 - coefficient de sécurité tenant compte des surtensions et de la simultanéité;
 - courant nominal absorbé par les différents art.
- DE** Bei der Planung einer Beleuchtungs- und Elektroanlage bestimmen Sie die zulässigen Höchstströme unter Berücksichtigung folgender Faktoren:
- 9A: von den Klemmleisten zugelassener Nennstrom;
 - Sicherheitskoeffizient zur Einbeziehung von Überspannung und Gleichzeitigkeit;
 - von den einzelnen art. aufgenommener Nennstrom.
- NL** Bij het ontwerpen van de verlichtingstechnische en elektrische installatie moet u de maximaal toegestane stroomtoevoer vaststellen door rekening te houden met de volgende factoren:
- 9A: nominale stroom toegestaan op klemmenstroken;
 - veiligheidscoëfficiënt om rekening te houden met overspanning en gelijktijdigheid;
 - nominale opgenomen stroom van de enkele Art.
- ES** Durante la proyectación de la instalación luminotécnica y eléctrica, determinar las corrientes máximas permitidas, en consideración de los factores siguientes:
- 9A: corriente nominal permitida de las borneras;
 - coeficiente de seguridad para considerar sobretensiones y contemporaneidades;
 - corriente nominal absorbida por los art. individuales.
- DA** I projekteringen af det belysningstekniske og elektriske anlæg, skal man undersøge den maks. tilladte strømstyrke, idet man tager højde for følgende:
- 9A: nominel tilladt strømstyrke fra klemrækkerne
 - sikkerhedskoefficient for at sikre mod overspænding og samtidighed
 - nominel absorberet strømstyrke på de enkelte dele

- NO** Under prosjektering av det belysningstekniske og elektriske anlegget, må maksimal tillatt strøm beregnes, ved å ta med i betraktningen følgende faktorer:
- 9A: merkestrøm god tatt av klemmebrettene;
 - sikkerhetskoeffisient for å holde oversikt over overstrøm og samtidig påslåing;
 - merkestrøm som opptas av de enkelte modulene.
- SV** Vid projekteringen av belysningsystemet och det elektriska systemet ska max. tillåten ström fastställas. Ta hänsyn till följande faktorer:
- 9A: Tillåten nominell ström från kopplingsplintarna.
 - Säkerhetskoefficient för att ta hänsyn till överspänningar och sammanlagningar.
 - Tillförd nominell ström från enskilda artiklar.
- RU** При расчете светотехнической системы и электропроводки определите максимальный допустимый ток с учетом следующих факторов:
- 9A: номинальный допустимый ток, допустимый в клеммных колодках;
 - коэффициент безопасности для учета перенапряжения и одновременного включения;
 - номинальный ток, поглощаемый отдельными изделиями.
- ZH** 设计电器、照明设备的时候必须参照下列数据，确定允许的最大电流：
- 9A：接头允许的额定电流
 - 为监控超电压与同时性的安全系数；
 - 每个组件的额定吸收电流。
- عند تصميم جهاز الإضاءة والتديدات الكهربائية، حدّد الحد الأقصى للتيار المسموح به، من خلال الأخذ بعين الاعتبار العوامل التالية:
- 9 أمبير: التيار الاسمي به على لوحة أطراف التوصيل
 - عامل الأمان للأخذ بعين الاعتبار جاوز الفلطية والتزامن
 - الفلطية الاسمية الممتصة من قبل الأصناف المفردة.
- AR**

ART. PD04

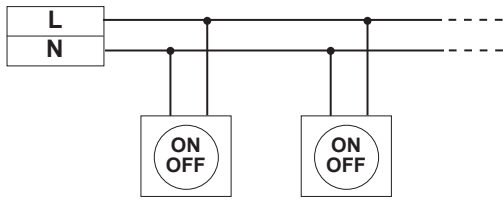

ART. PD05

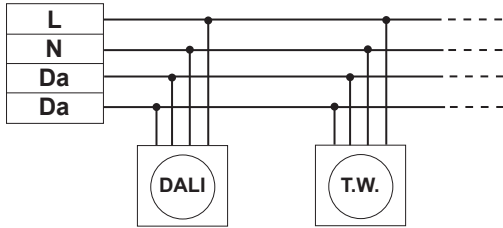

ART. PD05

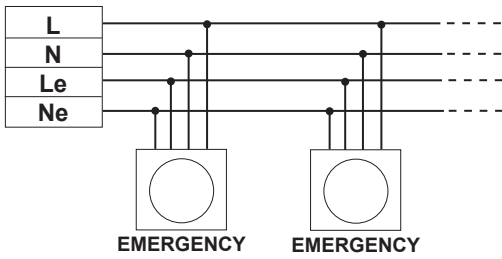

ART. PD05

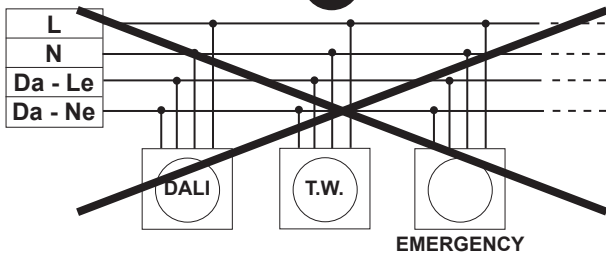

ART. PD07

NR.2 X MALE
NR.1 X FEMALE
NR.1 X DISTRIBUTOR
DALI / T.W.

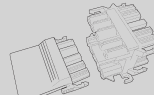

CABLE

ART. PD05

27 mm 7-9 mm



FEMALE

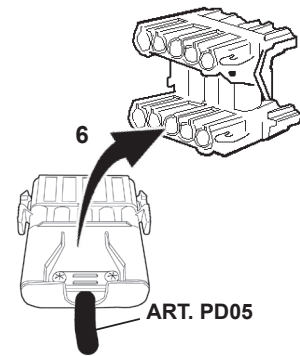
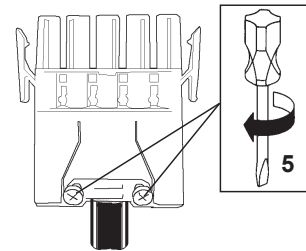
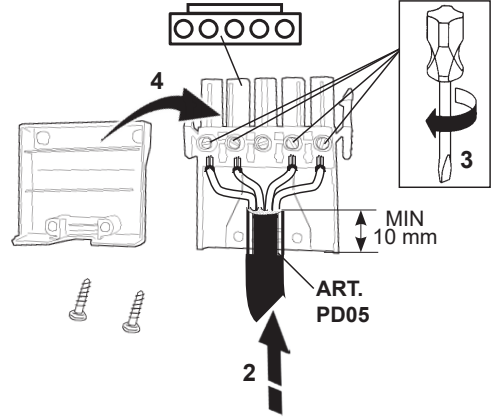

DALI / T.W.

Rosso
Red
Rouge
Rot
Rood
Rojo
Rød
Röd
Röd
Красный
红色
أحمر

Marrone
Brown
Braun
Bruin
Marrón
Brun
Brun
Brun
Коричневый
棕色
بني

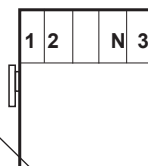

Bianco
White
Blanc
Weiß
Wit
Blanco
Hvid
White
Vit
Белый
白色
أبيض

Blu
Blue
Bleu
Blau
Blauw
Azul
Blá
Blá
Blá
Синий
蓝色
أزرق

ART. PD05

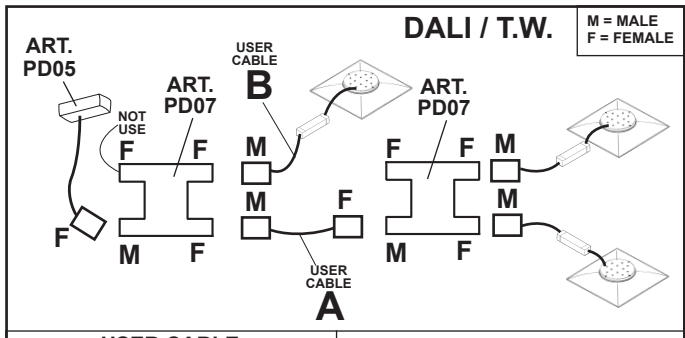

USER CABLE		
Ø mm	CABLE SECTION mm ²	
A	6,5 - 14	4 x 1,5
B	6,5 - 8	4 x 0,75 - 1,5

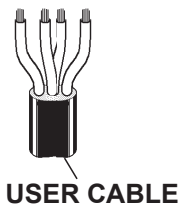
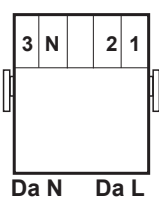
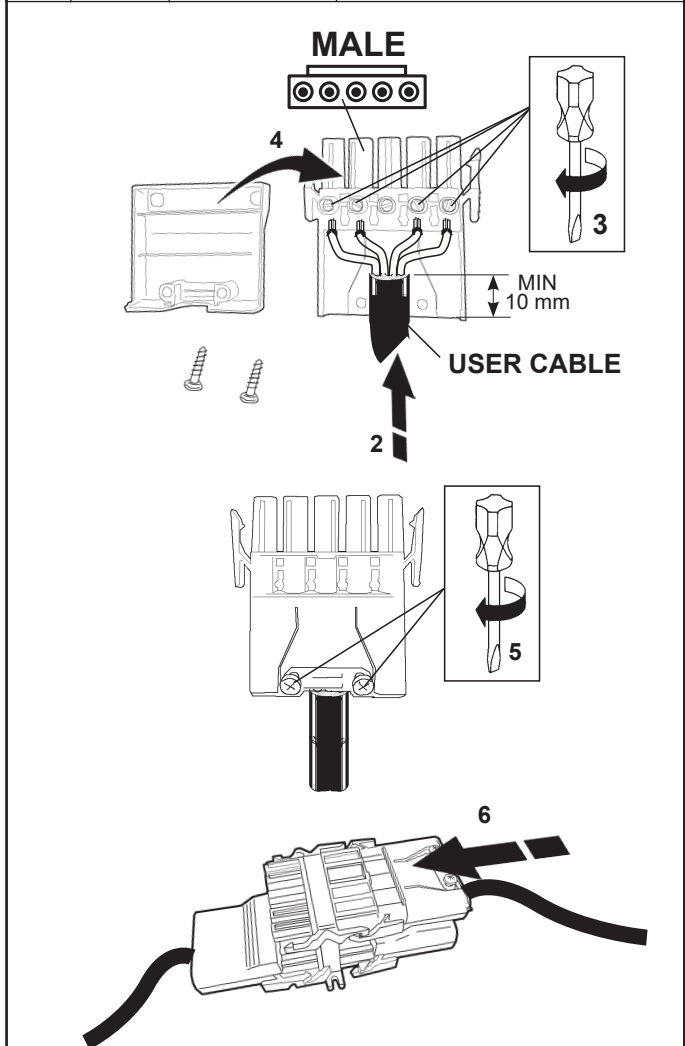

ART. PD07

NR.2 X MALE
NR.1 X FEMALE
NR.1 X DISTRIBUTOR

EMERGENCY

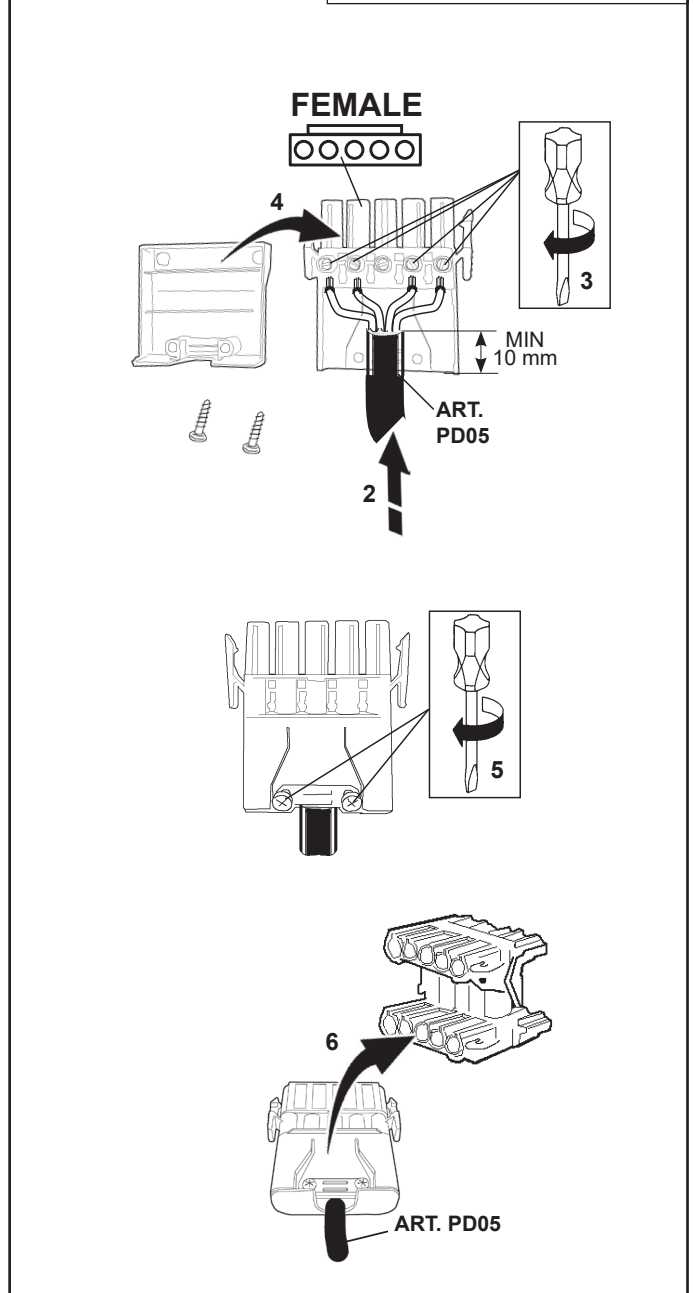
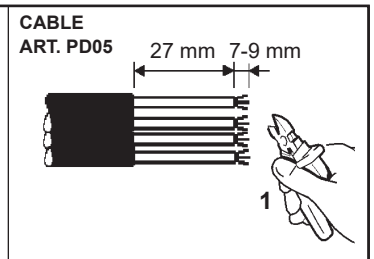

EMERGENCY

- Rosso
- Red
- Rouge
- Rot
- Rood
- Rojo
- Röd
- Röd
- Röd
- Красный
- 红色
- أحمر

- Bianco
- White
- Blanc
- Weiß
- Wit
- Blanco
- Hvid
- White
- Vit
- Белый
- 白色
- أبيض

- Marrone
- Brown
- Marron
- Braun
- Bruin
- Marrón
- Brun
- Brun
- Brun
- Коричневый
- 棕色
- بنى

- Blu
- Blue
- Bleu
- Blaui
- Blaui
- Azul
- Blå
- Blå
- Blå
- Синий
- 蓝色
- أزرق

ART . PD05

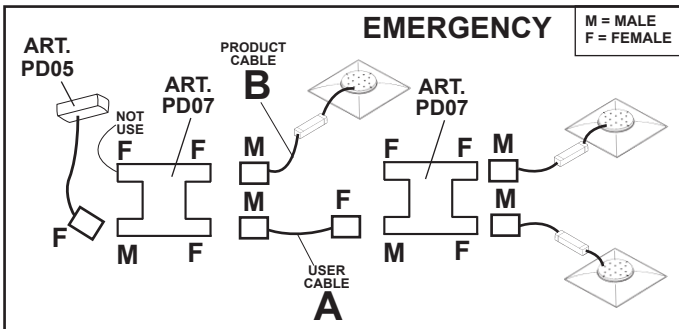

USER CABLE		
Ø mm	CABLE SECTION mm ²	
A 6,5 - 14	4 x 1,5	

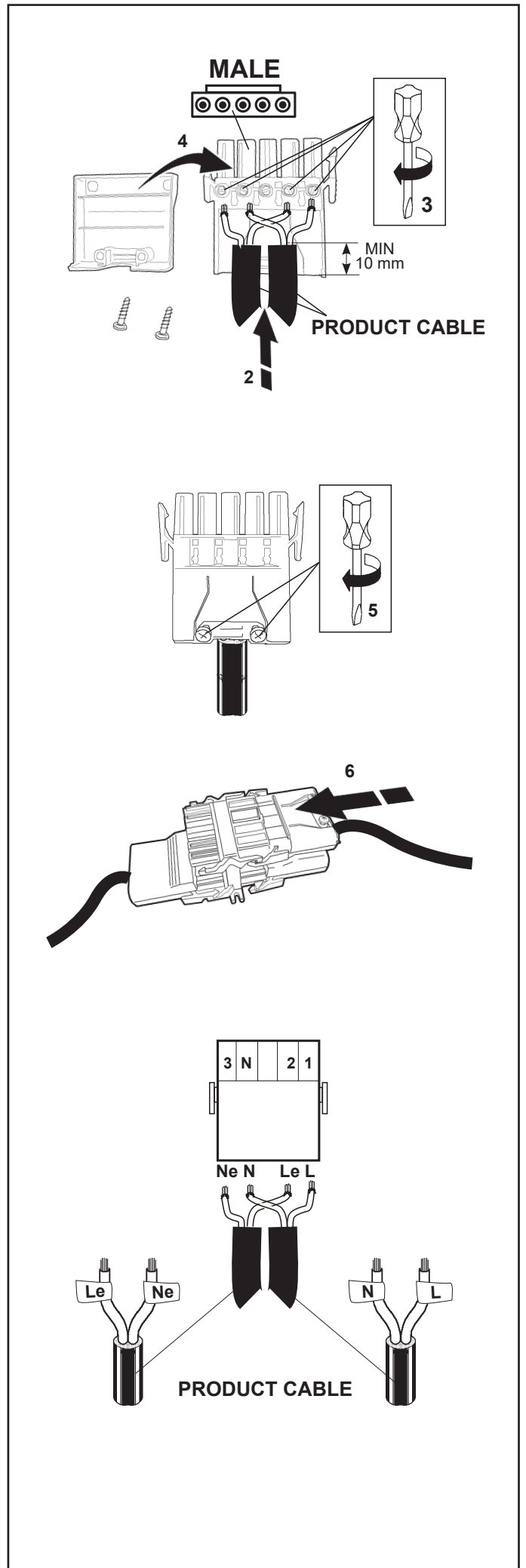
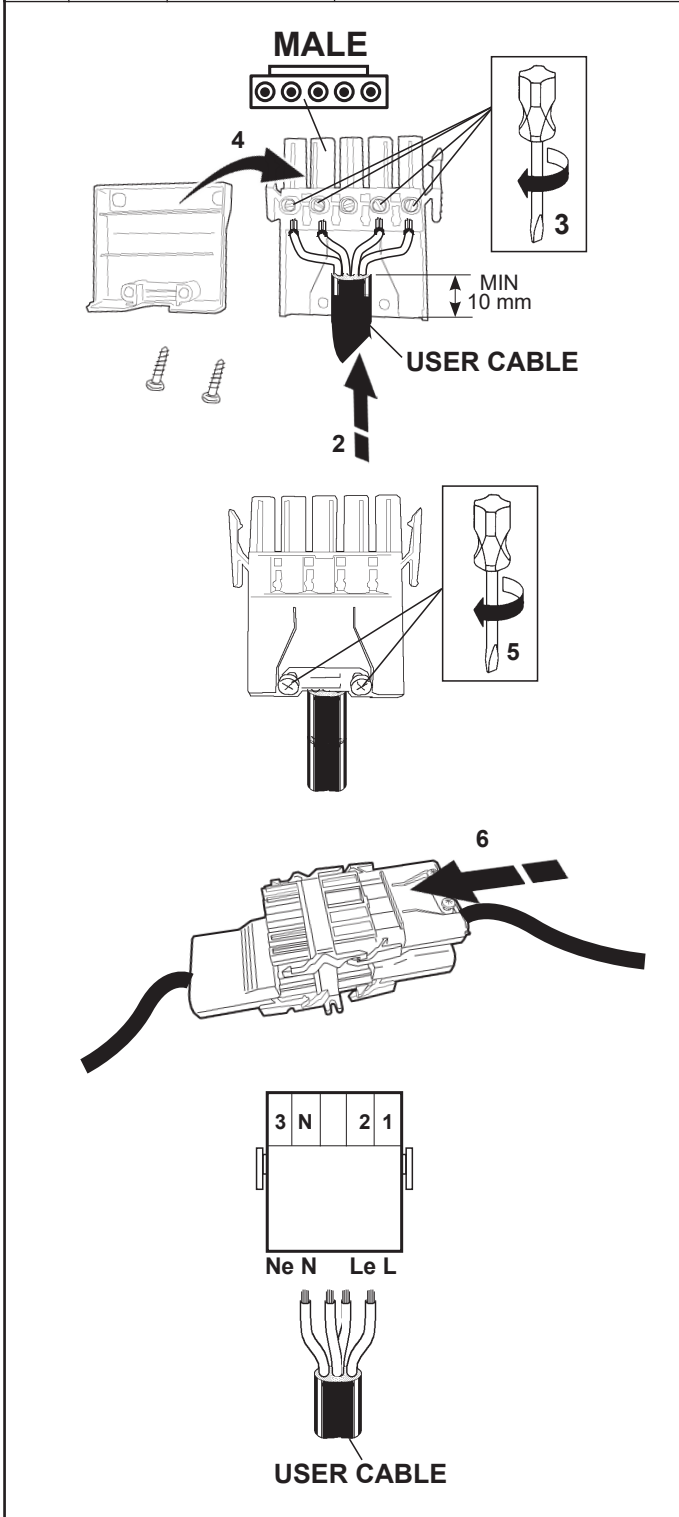

ART. PD39

NR.2 X MALE
NR.1 X FEMALE
NR.1 X DISTRIBUTOR

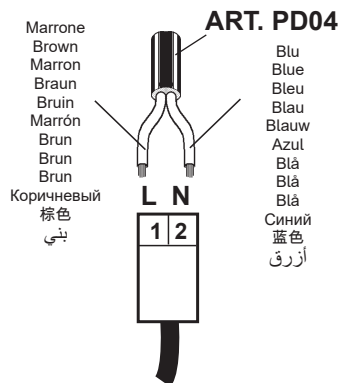
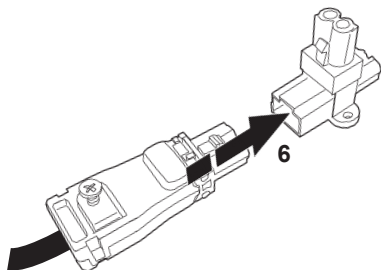
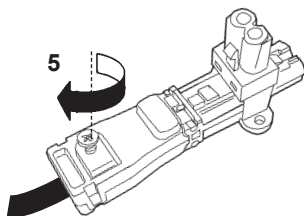
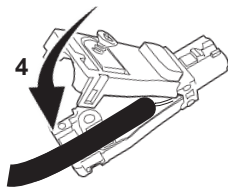
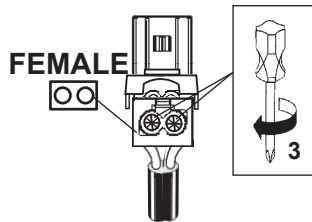
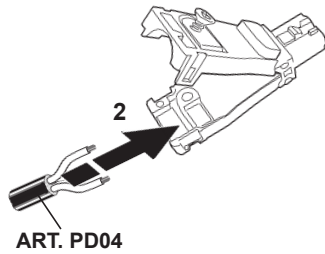
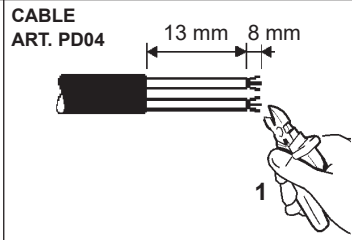

M = MALE
F = FEMALE

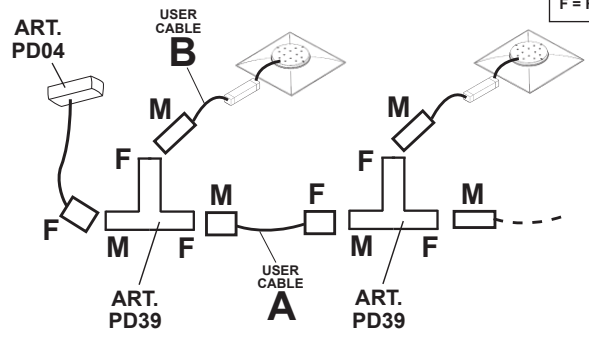

USER CABLE		
	Ø mm	CABLE SECTION mm ²
A	5,5 - 8	2 x 1,5
B	5,5 - 8	2 x 0,75 - 1,5

13 mm 8 mm

1

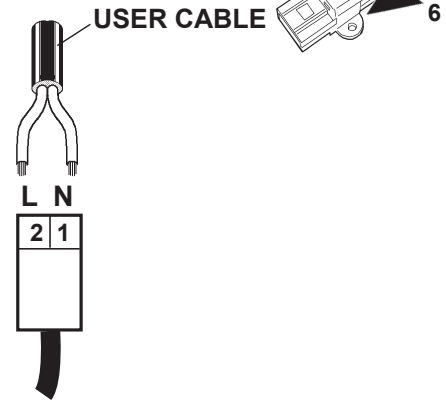
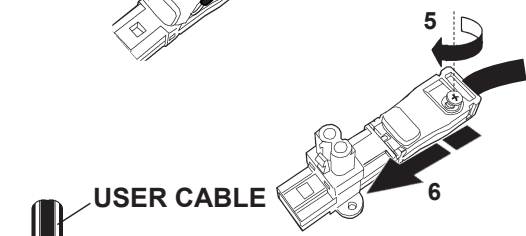
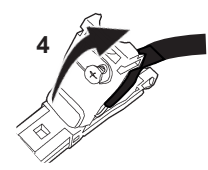
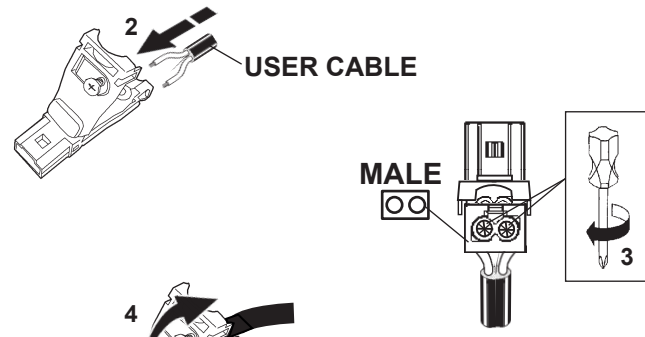

IT Per il cablaggio elettrico fare riferimento al foglio istruzioni del prodotto.

EN Please refer to the product instruction sheet for the electric wiring.

FR Informations zur elektrischen Verkabelung können Sie der Montageanleitung des Produkts entnehmen.

DE Die Membran nur an den für den Kabeldurchgang verwendeten Löchern durchstoßen.

NL P/Voor de elektrische bedrading raadpleegt u het instructieblaadje in het product.

ES Para el cableado eléctrico hágase referencia a la hoja de instrucciones del producto.

DA Membranen må kun gennembrydes ved de huller, der skal anvendes til kabelføring.

NO Indhent opplysninger om ledningsføringen i produktets vejledning.

SV Angående kabeldragningen, se produktens instruktionsblad.

RU Порядок монтажа электропроводки смотрите в инструкциях к продукту.

ZH 针对布线，请参阅产品说明表。

AR بالنسبة للأسلاك الكهربائية، راجع ورقة تعليمات المنتج.

ART. PD00
PD01
PD02

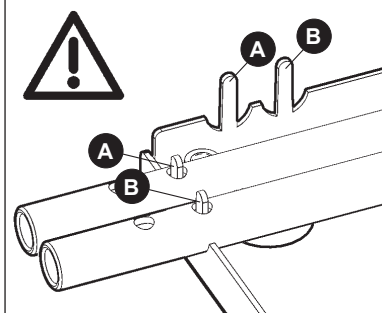
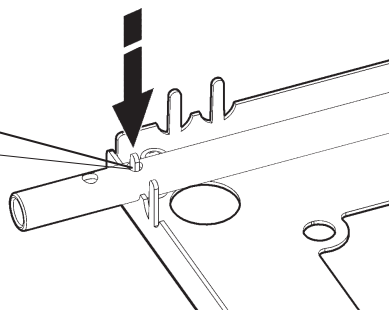
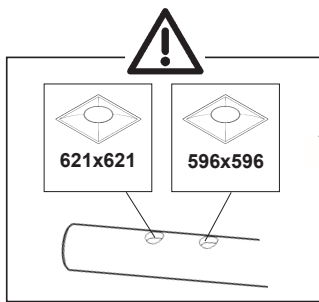

RODS POSITION

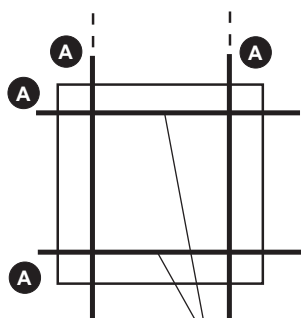
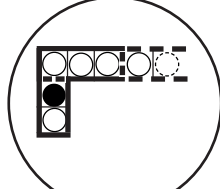
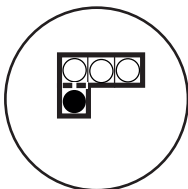
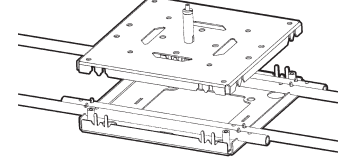
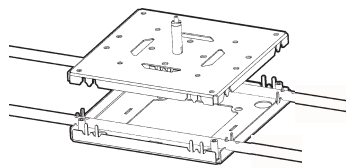
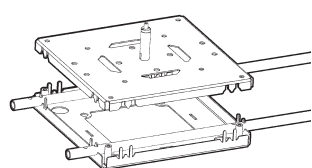
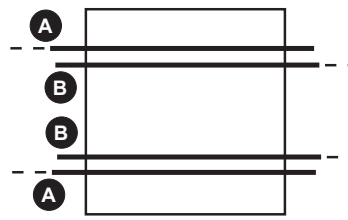
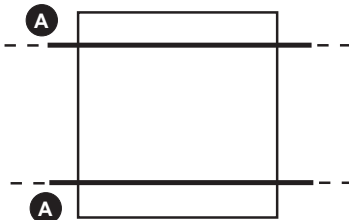
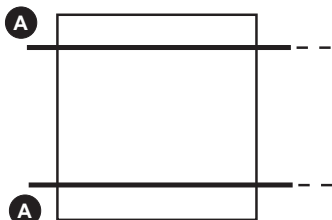
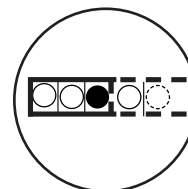
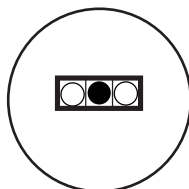
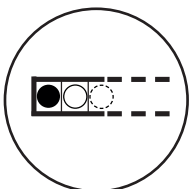

ART.
PD02

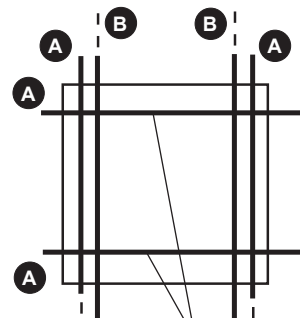

ART.
PD02

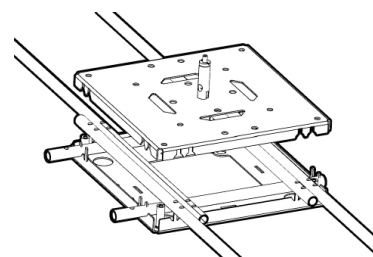
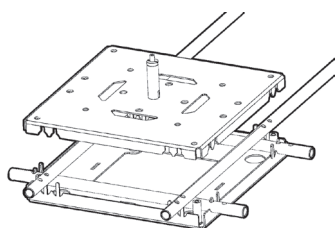

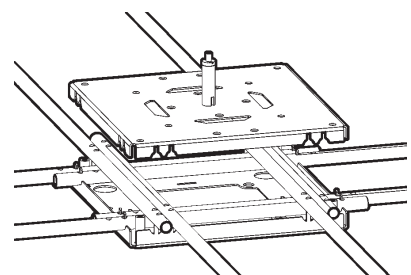
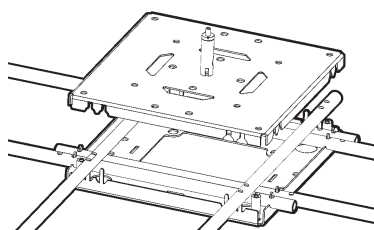
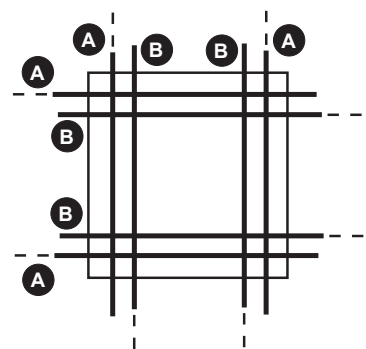
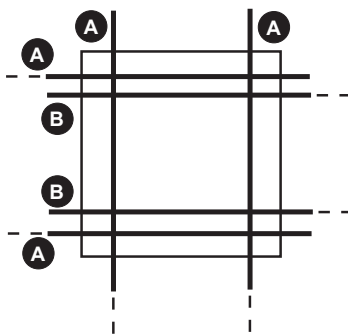
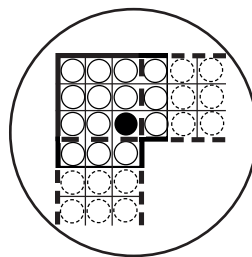
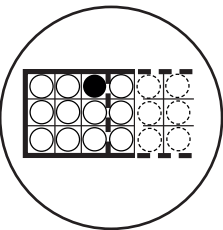
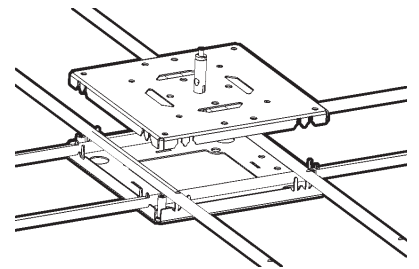
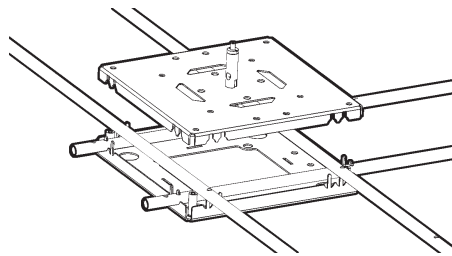
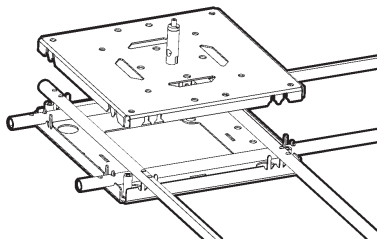
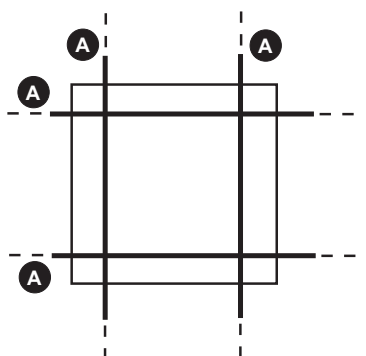
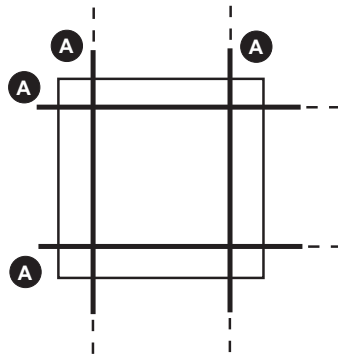
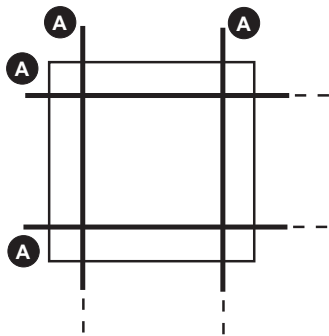
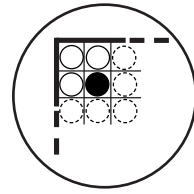
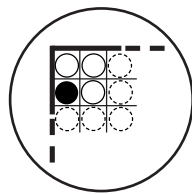
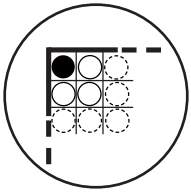

COUPLING BETWEEN STRUCTURES

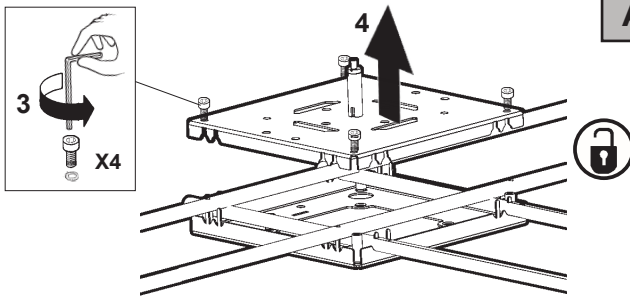
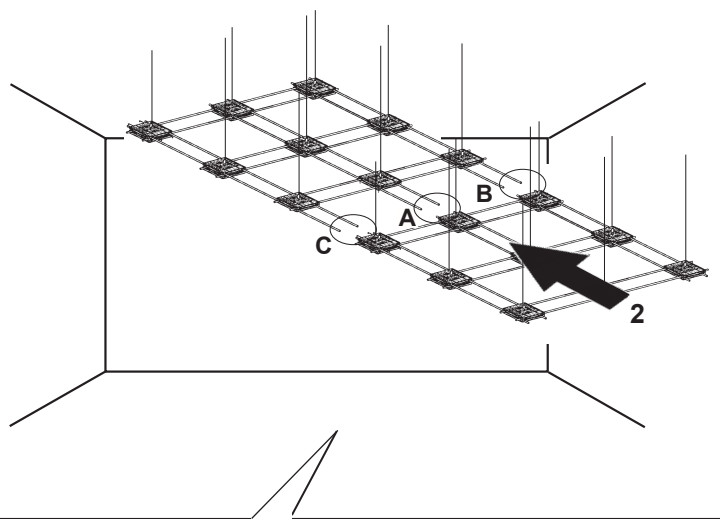
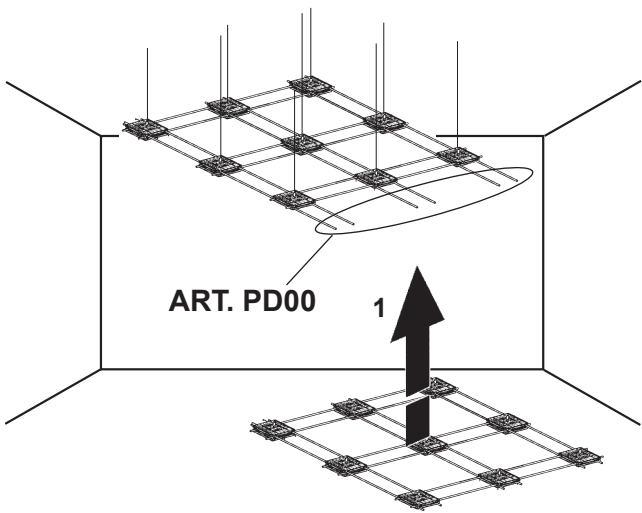
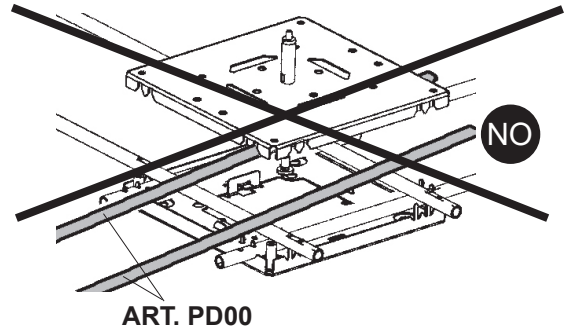
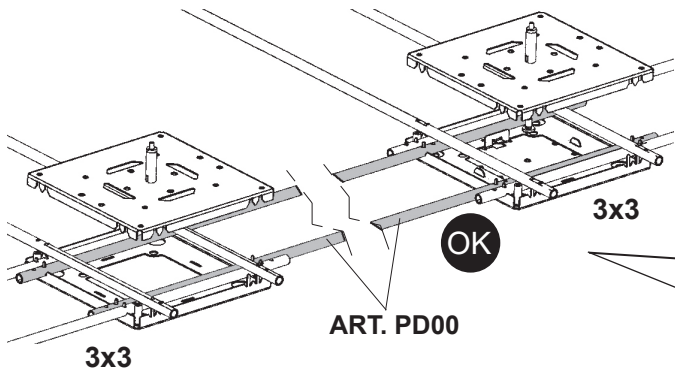
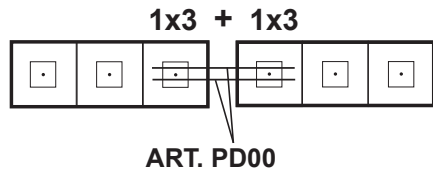
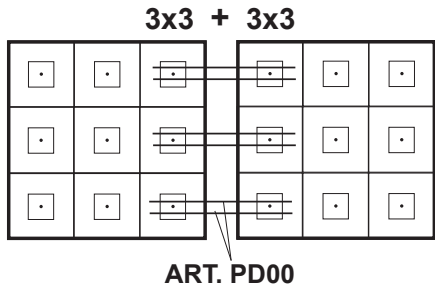

A - B - C

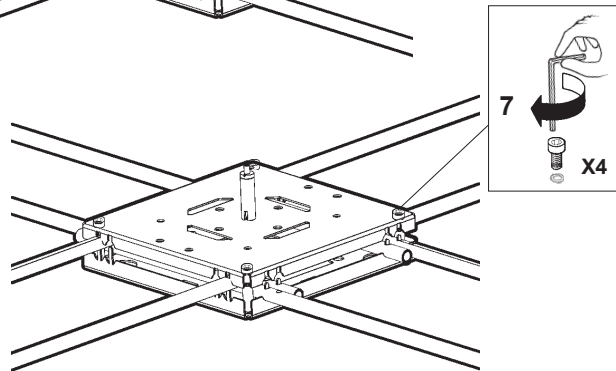
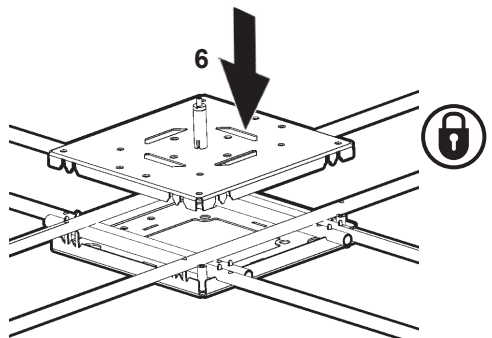
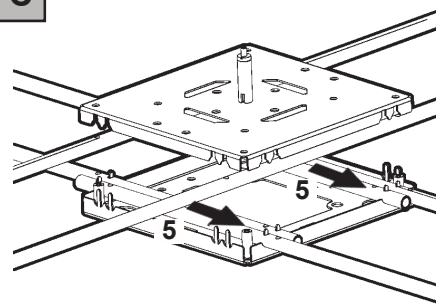

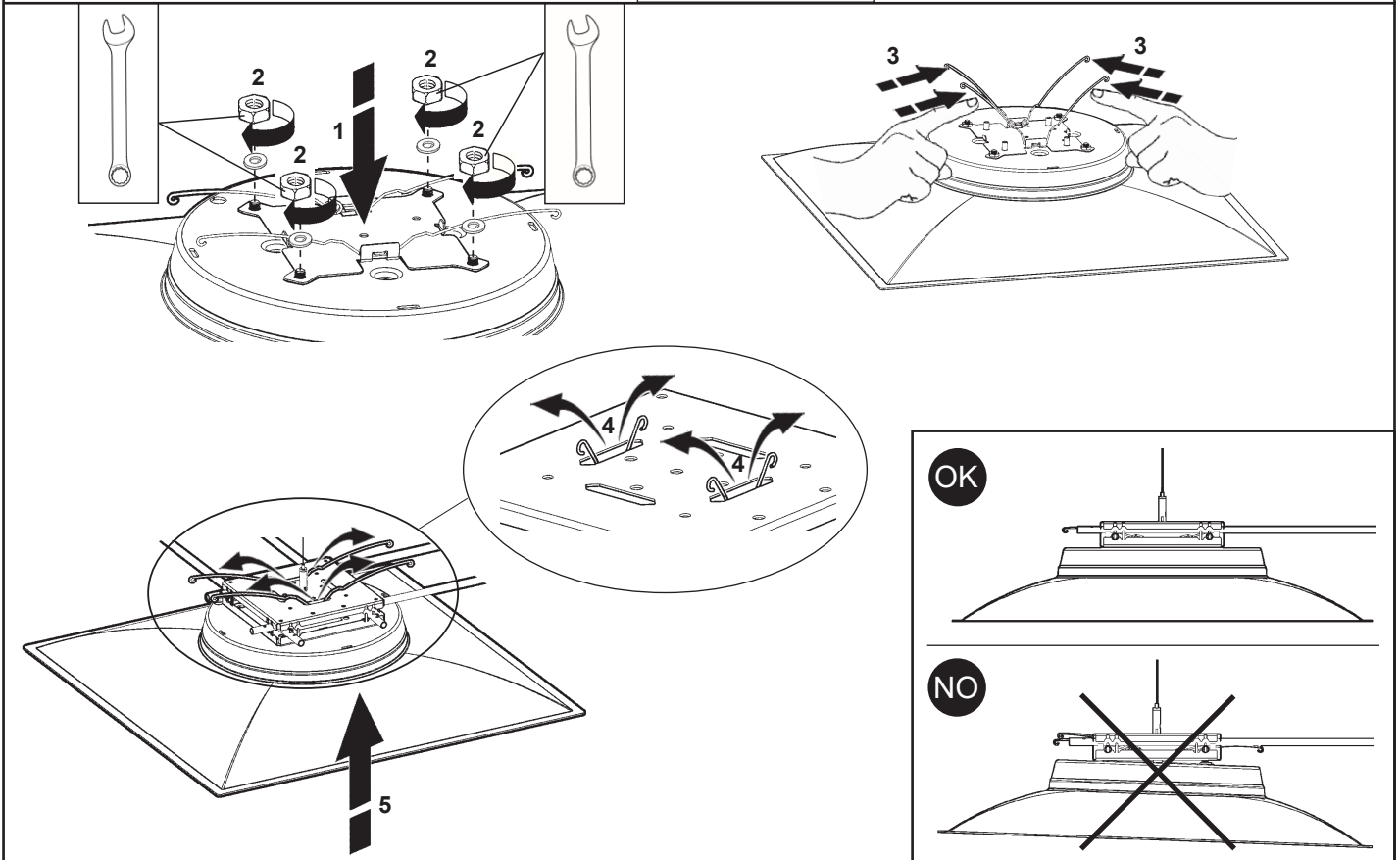
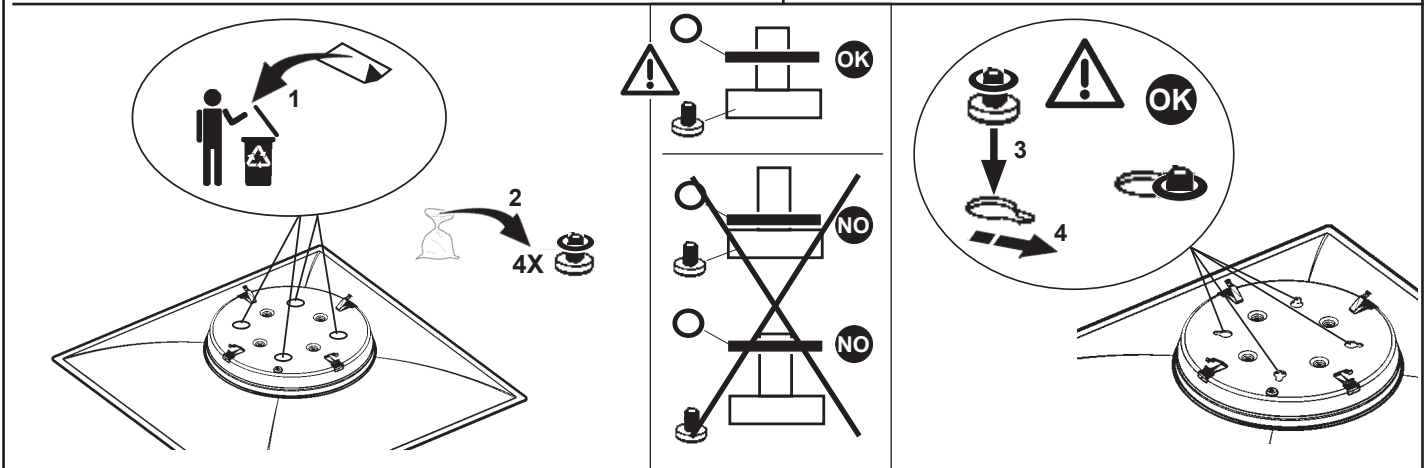
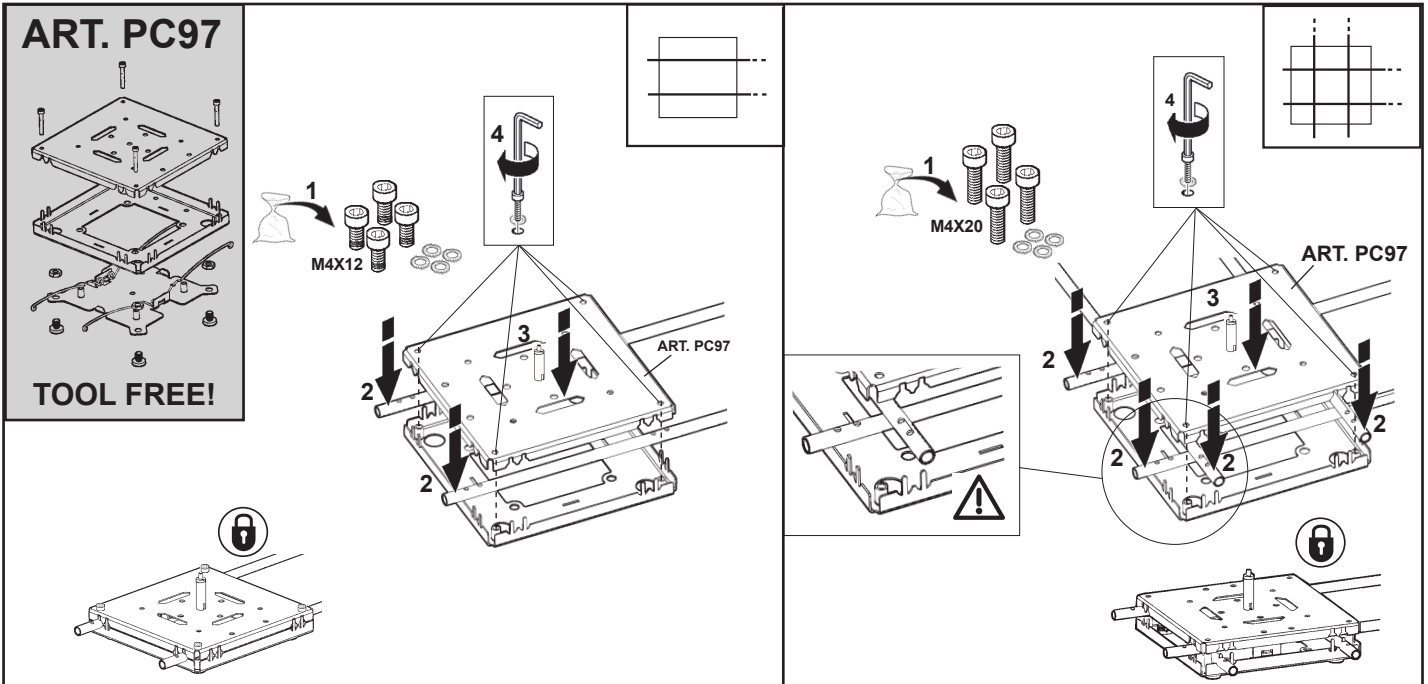

ART. PD40

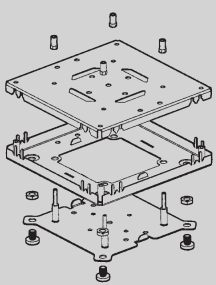

WITH TOOL!

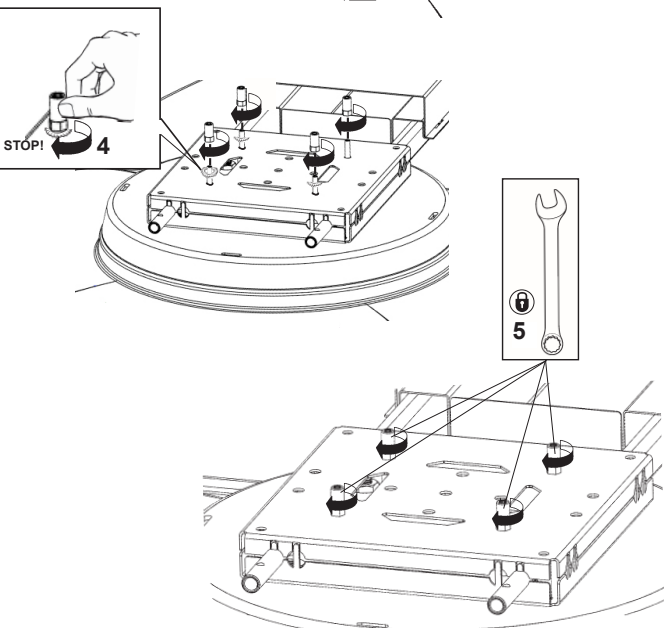
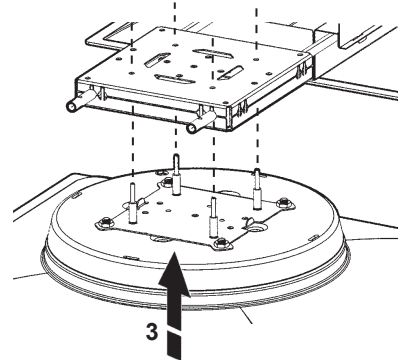
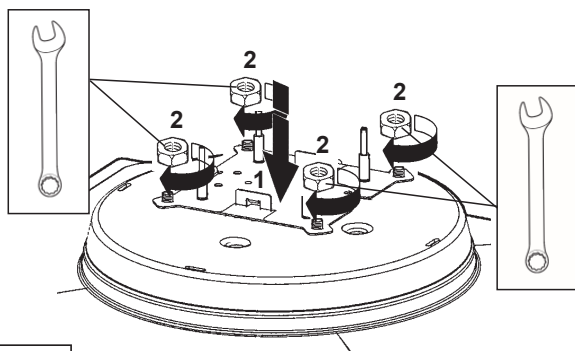
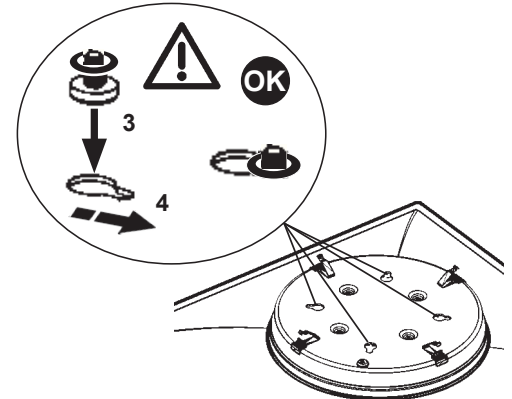
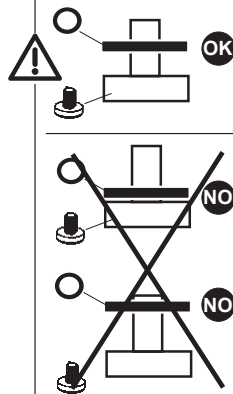
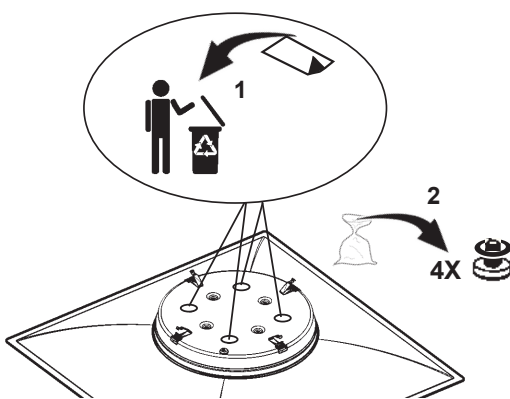
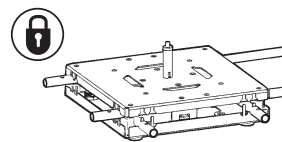
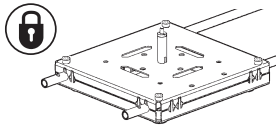
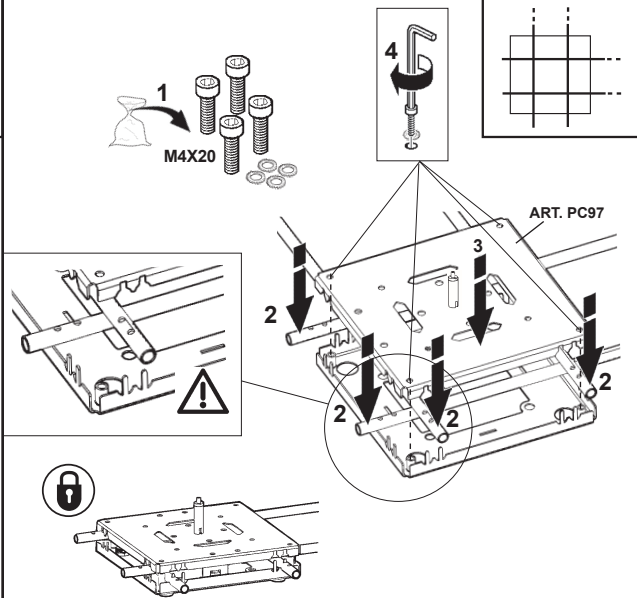
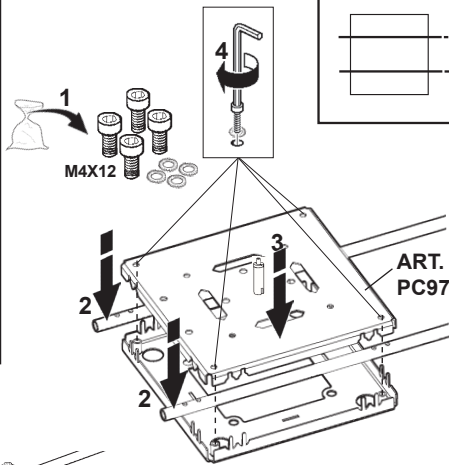

ART. PC97 - PD40

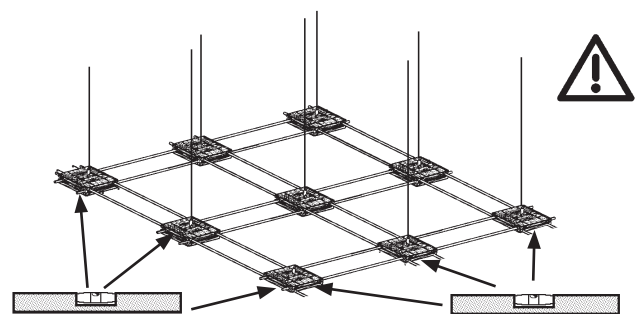
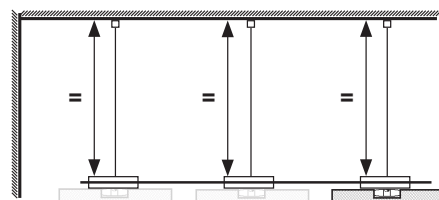

ART. PC98

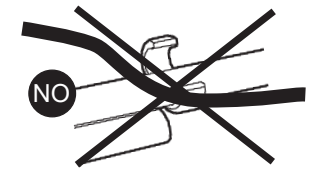
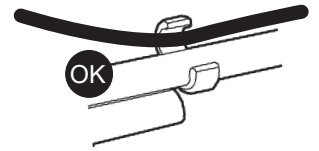
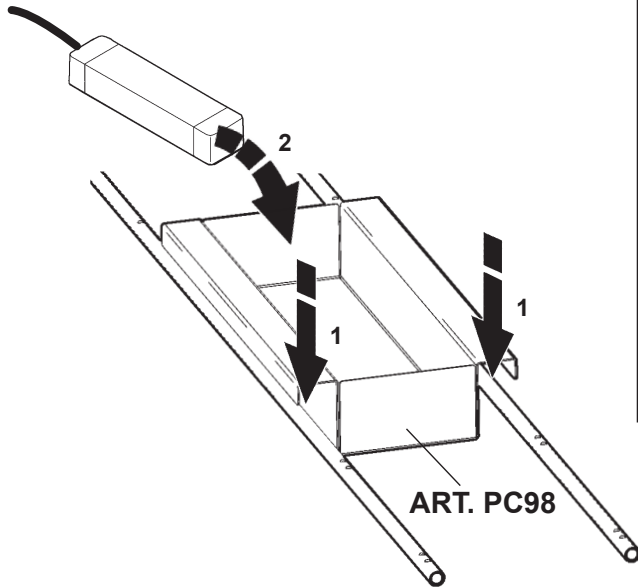
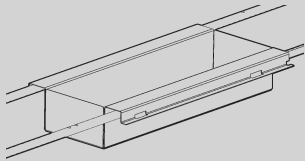

ART. PC98

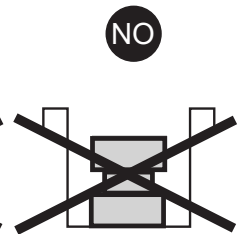
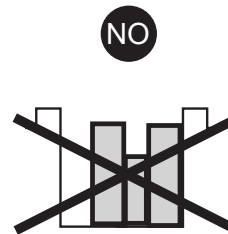
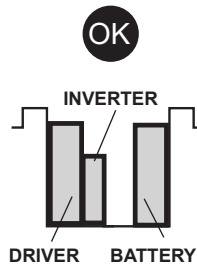
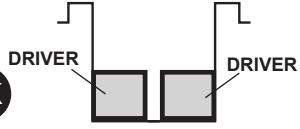
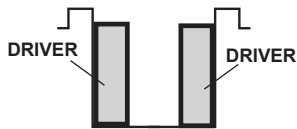
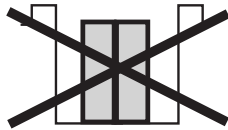
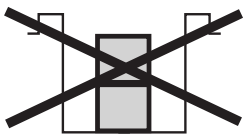
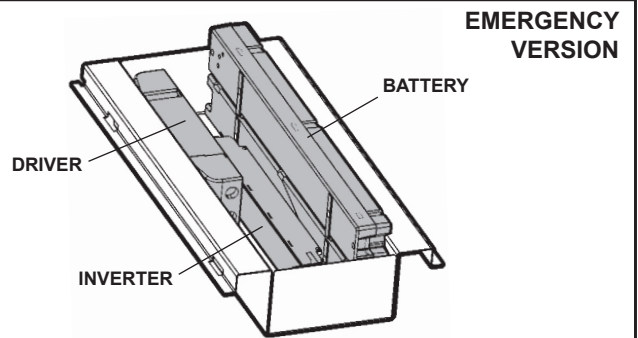
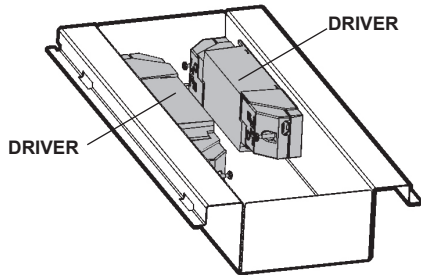

ART. PC99

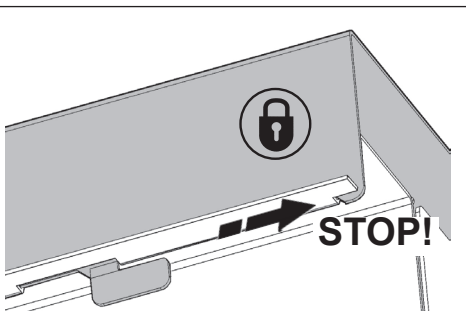
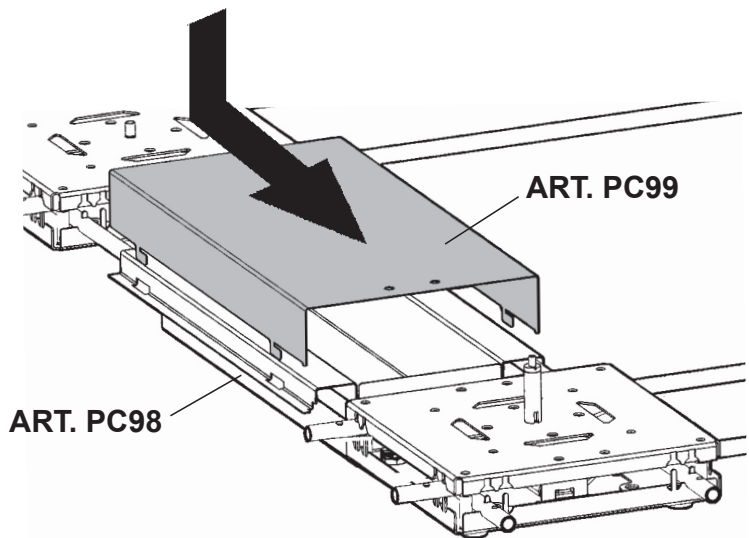
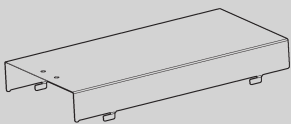

ART. PC96

ONLY FOR WHITE PRODUCT

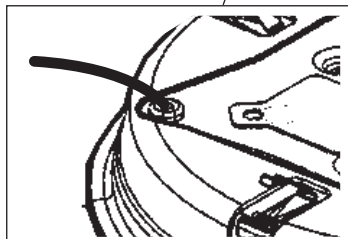
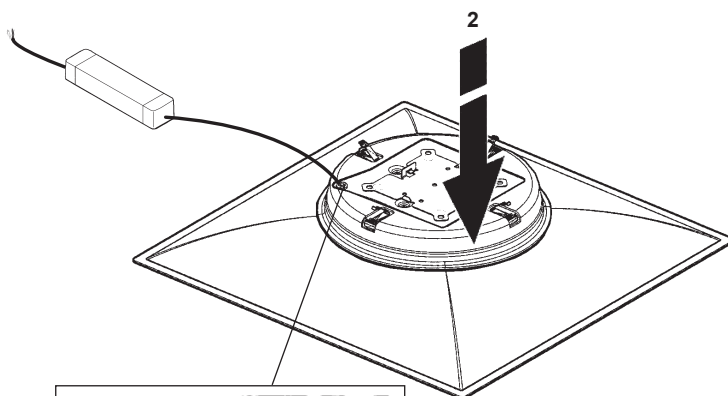
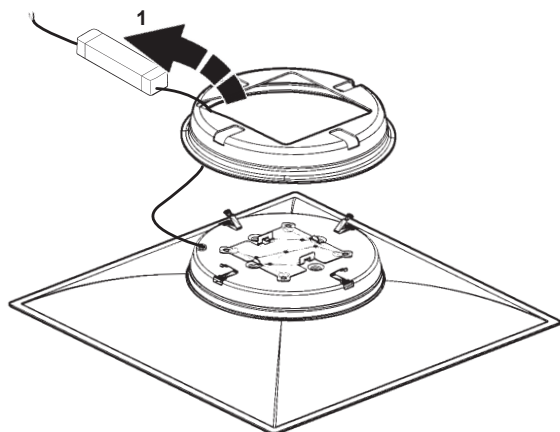
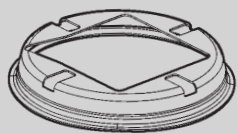

IT Consultare il foglio istruzioni del prodotto.

EN Refer to the product instruction sheet.

FR Veuillez consulter la notice d'instructions du produit.

DE Das Anweisungsblatt des Produkts zu Rate ziehen.

NL Raadpleeg het instructieblad van het product.

ES Consulte la hoja de instrucciones del producto.

DA Se produktvejledning.

NO Se anvisningene for produktet.

SV Se produktens instruktionsblad.

RU Смотреть прилагающийся инструкции к изделию

ZH 请参考产品说明书。

AR

الرجوع إلى ورقة تعليمات المنتج



2.510.285.01
IS17795/01

iGuzini

- IT** Consultare il foglio istruzioni del prodotto art. PD04 - PD05.
EN Refer to the product instruction sheet art. PD04 - PD05.
FR Veuillez consulter la notice d'instructions du produit art. PD04 - PD05.
DE Das Anweisungsblatt des Produkts zu Rate ziehen art. PD04 - PD05.
NL Raadpleeg het instructieblad van het product art. PD04 - PD05.
ES Consulte la hoja de instrucciones del producto art. PD04 - PD05.
DA Se produktvejledningerne art. PD04 - PD05.
NO Se anvisningene for produktet art. PD04 - PD05.
SV Se produktens instruktionsblad art. PD04 - PD05.
RU Смотреть прилагающийся инструкции к изделию art. PD04 - PD05
ZH 请参考产品说明书 art. PD04 - PD05.

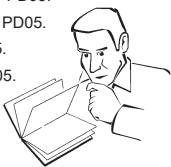

راجع ورقة التعليمات الخاصة بـفـن المنتج.



ART. PD04



ART. PD05

2.510.285.01
IS17795/01

iGuzini

- IT** Consultare il foglio istruzioni del prodotto art. PD04 - PD05.
EN Refer to the product instruction sheet art. PD04 - PD05.
FR Veuillez consulter la notice d'instructions du produit art. PD04 - PD05.
DE Das Anweisungsblatt des Produkts zu Rate ziehen art. PD04 - PD05.
NL Raadpleeg het instructieblad van het product art. PD04 - PD05.
ES Consulte la hoja de instrucciones del producto art. PD04 - PD05.
DA Se produktvejledningerne art. PD04 - PD05.
NO Se anvisningene for produktet art. PD04 - PD05.
SV Se produktens instruktionsblad art. PD04 - PD05.
RU Смотреть прилагающийся инструкции к изделию art. PD04 - PD05
ZH 请参考产品说明书 art. PD04 - PD05.

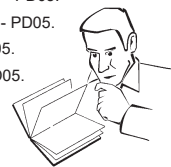

راجع ورقة التعليمات الخاصة بـفـن المنتج.



ART. PD04



ART. PD05

2.510.285.01
IS17795/01

iGuzini

- IT** Consultare il foglio istruzioni del prodotto art. PD04 - PD05.
EN Refer to the product instruction sheet art. PD04 - PD05.
FR Veuillez consulter la notice d'instructions du produit art. PD04 - PD05.
DE Das Anweisungsblatt des Produkts zu Rate ziehen art. PD04 - PD05.
NL Raadpleeg het instructieblad van het product art. PD04 - PD05.
ES Consulte la hoja de instrucciones del producto art. PD04 - PD05.
DA Se produktvejledningerne art. PD04 - PD05.
NO Se anvisningene for produktet art. PD04 - PD05.
SV Se produktens instruktionsblad art. PD04 - PD05.
RU Смотреть прилагающийся инструкции к изделию art. PD04 - PD05
ZH 请参考产品说明书 art. PD04 - PD05.

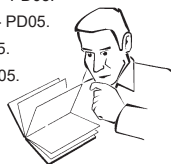

راجع ورقة التعليمات الخاصة بـفـن المنتج.



ART. PD04



ART. PD05

2.510.285.01
IS17795/01

iGuzini

- IT** Consultare il foglio istruzioni del prodotto art. PD04 - PD05.
EN Refer to the product instruction sheet art. PD04 - PD05.
FR Veuillez consulter la notice d'instructions du produit art. PD04 - PD05.
DE Das Anweisungsblatt des Produkts zu Rate ziehen art. PD04 - PD05.
NL Raadpleeg het instructieblad van het product art. PD04 - PD05.
ES Consulte la hoja de instrucciones del producto art. PD04 - PD05.
DA Se produktvejledningerne art. PD04 - PD05.
NO Se anvisningene for produktet art. PD04 - PD05.
SV Se produktens instruktionsblad art. PD04 - PD05.
RU Смотреть прилагающийся инструкции к изделию art. PD04 - PD05
ZH 请参考产品说明书 art. PD04 - PD05.

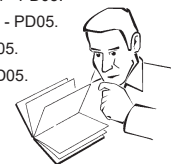

راجع ورقة التعليمات الخاصة بـفـن المنتج.



ART. PD04



ART. PD05

2.510.285.01
IS17795/01

iGuzini

- IT** Consultare il foglio istruzioni del prodotto art. PD04 - PD05.
EN Refer to the product instruction sheet art. PD04 - PD05.
FR Veuillez consulter la notice d'instructions du produit art. PD04 - PD05.
DE Das Anweisungsblatt des Produkts zu Rate ziehen art. PD04 - PD05.
NL Raadpleeg het instructieblad van het product art. PD04 - PD05.
ES Consulte la hoja de instrucciones del producto art. PD04 - PD05.
DA Se produktvejledningerne art. PD04 - PD05.
NO Se anvisningene for produktet art. PD04 - PD05.
SV Se produktens instruktionsblad art. PD04 - PD05.
RU Смотреть прилагающийся инструкции к изделию art. PD04 - PD05
ZH 请参考产品说明书 art. PD04 - PD05.

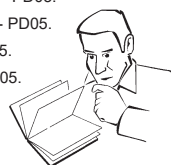

راجع ورقة التعليمات الخاصة بـفـن المنتج.



ART. PD04



ART. PD05

2.510.285.01
IS17795/01

iGuzini

- IT** Consultare il foglio istruzioni del prodotto art. PD04 - PD05.
EN Refer to the product instruction sheet art. PD04 - PD05.
FR Veuillez consulter la notice d'instructions du produit art. PD04 - PD05.
DE Das Anweisungsblatt des Produkts zu Rate ziehen art. PD04 - PD05.
NL Raadpleeg het instructieblad van het product art. PD04 - PD05.
ES Consulte la hoja de instrucciones del producto art. PD04 - PD05.
DA Se produktvejledningerne art. PD04 - PD05.
NO Se anvisningene for produktet art. PD04 - PD05.
SV Se produktens instruktionsblad art. PD04 - PD05.
RU Смотреть прилагающийся инструкции к изделию art. PD04 - PD05
ZH 请参考产品说明书 art. PD04 - PD05.

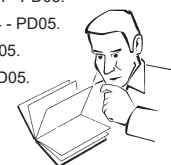

راجع ورقة التعليمات الخاصة بـفـن المنتج.



ART. PD04



ART. PD05