

## LANDER

iGuzzini

IT ISTRUZIONI PER L'INSTALLAZIONE DEL SISTEMA "LANDER"  
 EN INSTALLATION INSTRUCTIONS FOR "LANDER" SYSTEM MODE  
 FR D'INSTALLATION DU SYSTEME "LANDER"  
 DE HINWEISE ZUR INSTALLATION DER "LANDER"  
 NL INSTRUCTIES VOOR HET INSTALLEREN VAN HET "LANDER"  
 ES INSTRUCCIONES PARA LA INSTALACIÓN DEL SISTEMA "LANDER"  
 DA INSTALLATIONSVEJLEDNING TIL SYSTEMET "LANDER"  
 ND INSTALLASJONSANVISNING FOR SYSTEMET "LANDER"  
 SV INSTALLATIONSANVISNINGAR FÖR SYSTEM "LANDER"  
 RU ИНСТРУКЦИИ ПО МОНТАЖУ СИСТЕМЫ «LANDER»  
 ZH "LANDER" 系统的安装说明

## IT ATTENZIONE:

LA SICUREZZA DELL'APPARECCHIO E' GARANTITA SOLO CON L'USO APPROPRIATO DELLE SEGUENTI ISTRUZIONI; PERTANTO E' NECESSARIO CONSERVARLE.

## EN WARNING:

THE SAFETY OF THIS FIXTURE IS GUARANTEED ONLY IF YOU COMPLY WITH THESE INSTRUCTIONS; REMEMBER TO CONSERVE IN A SAFE PLACE.

## FR ATTENTION:

LA SECURITE DE L'APPAREIL N'EST GARANTIE QU'EN CAS D'UTILISATION CORRECTE DES INSTRUCTIONS SUIVANTES; IL FAUT PAR CONSEQUENT LES CONSERVER.

## DE ACHTUNG:

DIE SICHERHEIT DES GERÄTES WIRD NUR DURCH SACHGEMÄSSE BEFOLGUNG NACHSTEHENDER ANWEISUNGEN GEWÄHRLEISTET; IHRE AUFBEWAHRUNG IST DESHALB SEHR WICHTIG.

## NL ATTENTIE:

DE VEILIGHEID VAN DE APPARATUUR IS SLECHTS DAN GEGARANDEERD ALS MEN DE VOLGENDE INSTRUCTIES STRIKT OPVOLGT; DAAROM MOET MEN ZE OOK BEWAREN.

## ES ATENCION:

LA SEGURIDAD DEL APARATO SE GARANTIZA SOLO CUMPLIENDO CUIDADOSAMENTE LAS SIGUIENTES INSTRUCCIONES; POR ELLO, ES NECESARIO CONSERVARLAS.

## DA BEMÆRK:

SIKKERHEDEN VED BRUG AF ARMATURET KAN KUN GARANTERES, HVIS DISSE ANVISNINGER FØLGES; SØRG DERFOR FOR AT GEMME DEM.

## ND ADVARSEL:

SIKKERHETEN TIL DETTE APPARATET GARANTERES KUN HVIS DU OVERHOLDER DISSE INSTRUKSJONENE; HUSK Å OPPBEVARE DEM PÅ ET TRYGT STED.

## SV OBSERVERA!

UTRUSTNINGENS SÄKERHET KAN ENDAST GARANTERAS OM DESSA ANVISNINGAR RESPEKTERAS I DETALJ. SPARA DÄRFÖR DESSA ANVISNINGAR FÖR FRAMTIDA KONSULTATION.

## RU ВНИМАНИЕ:

МЫ ГАРАНТИРУЕМ БЕЗОПАСНУЮ ЭКСПЛУАТАЦИЮ ИЗДЕЛИЯ ТОЛЬКО ПРИ СОБЛЮДЕНИИ СЛЕДУЮЩИХ ИНСТРУКЦИЙ; С ЭТОЙ ЦЕЛЬЮ НЕОБХОДИМО СОХРАНИТЬ ДАННУЮ БРОШЮРУ.

## ZH 警告:

为确保该装置安全, 请遵守操作指示, 并于安全场所放置。

IT N.B.: DURANTE L'INSTALLAZIONE DEL SISTEMA "LANDER" RISPETTARE SCRUPOLOSAMENTE LE NORME IMPIANTISTICHE NAZIONALI VIGENTI.

EN N.B.: WHEN INSTALLING THE "LANDER" SYSTEM, MAKE SURE ALL CURRENT NATIONAL REGULATIONS RELATING TO INSTALLATION ARE OBSERVED.

FR N.B.: LORS DE L'INSTALLATION DU SYSTÈME "LANDER" VEUILLEZ RESPECTER RIGOREUSEMENT LES NORMES EN VIGUEUR EN LA MATIÈRE DANS LE PAYS.

DE N.B.: BEACHTENSIEBEIDERINSTALLATIONDESSYSTEMS"LANDER"UNBEDINGT DIE IM LAND GELTENDEN ANLAGETECHNISCHEN VORSCHRIFTEN.

NL N.B.: BIJ HET INSTALLEREN VAN HET "LANDER" SYSTEEM MOET U DE GELDENDE NATIONALE INSTALLATIENORMEN STRIKT NALEVEN.

ES NOTA: DURANTE LA INSTALACIÓN DEL SISTEMA "LANDER" RESPETARE SCRUPULOSAMENTE LAS NORMAS NACIONALES DE INSTALACIÓN EN VIGOR.

DA N.B.: UNDERINSTALLATIONAF"LANDER"SYSTEMETSKALMANNØJE OVERHOLDE DE GÆLDENDE REGLER FOR DISSE ANLÆG.

ND N.B.: UNDER INSTALLASJON AV SYSTEMET "LANDER" MÅ DE NASJONALE ANLEGGSFORSKRIFTENE OVERHOLDES NØYE.

SV OBS! UNDER INSTALLATION AV SYSTEMET "LANDER" SKA GÄLLANDE NATIO-NELLA INSTALLATIONSFORESKRIFTER RESPEKTERAS I DETALJ.

RU ПРИМЕЧАНИЕ: В ПРОЦЕССЕ МОНТАЖА СИСТЕМЫ "LANDER" СТРОГО СОБЛЮДАЙТЕ НАЦИОНАЛЬНЫЕ ДЕЙСТВУЮЩИЕ НОРМАТИВЫ ПО ЭЛЕКТРОПРОВОДКЕ.

ZH 注意: 在安装 "LANDER" 系统时请遵守设备的安装规定。

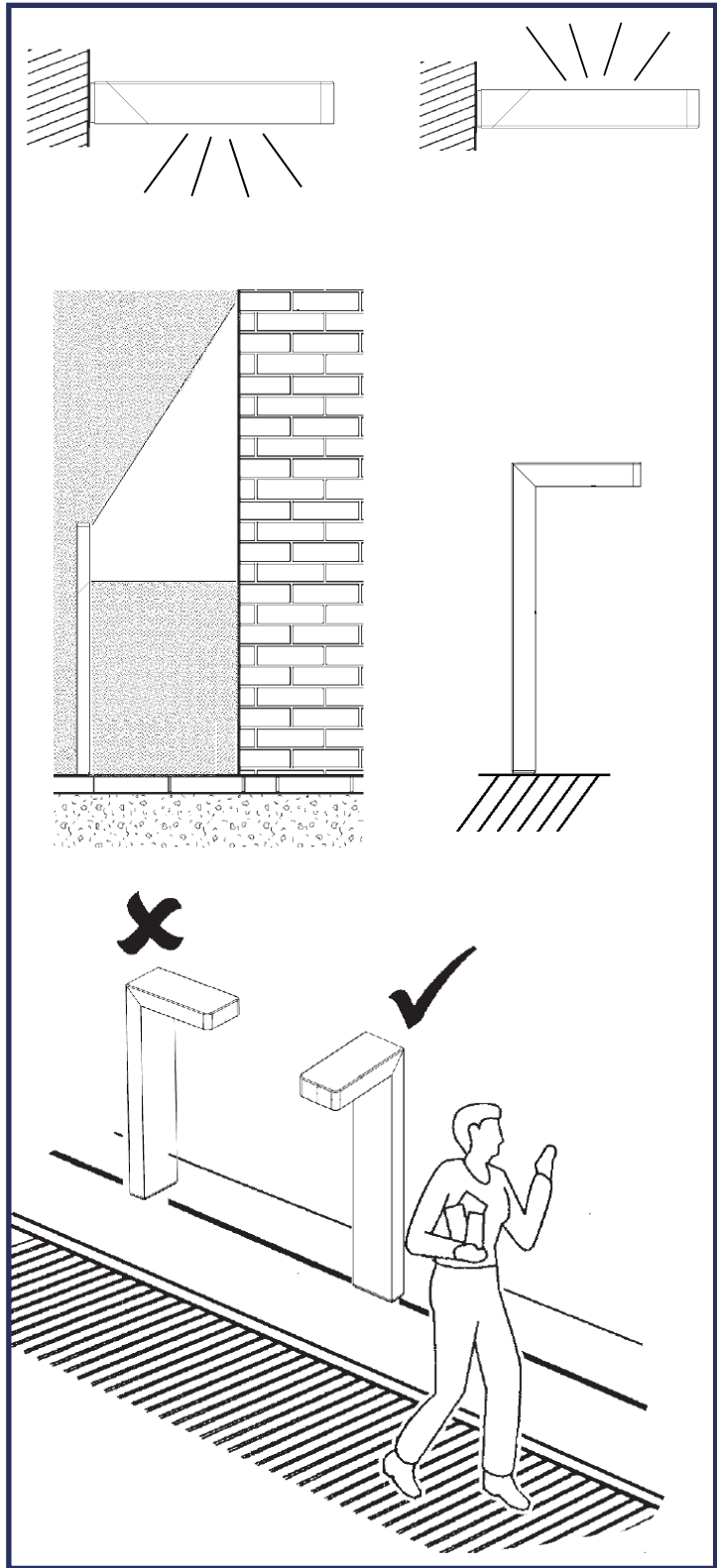

IT N.B.: Installando l'apparecchio, evitare che la base venga interrata o posizionata in punti soggetti al ristagno dell'acqua.

EN N.B.: Whilst installing the appliance, avoid concealing its base or placing it in areas which are susceptible to damp.

FR N.B.: Lors de l'installation de l'appareil, veillez à ce que la base ne soit pas enterrée ou positionnée dans un endroit sujet à la stagnation de l'eau.

DE N.B.: Bei der Installation des Gerätes ist darauf zu achten, daß das Unterteil nicht eingegraben oder an Stellen placiert wird, an denen sich Wasser stauen könnte.

NL N.B.: Het apparaat mag niet met de basis ingebouwd worden of op punten geïnstalleerd die stilstaand water veroorzaken.

ES NOTA: Al instalar el aparato, evite que la base se entierre o se coloque en puntos donde se pueda estancar el agua.

DA N.B.: Ved installation af armaturet skal man undgå, at soklen er under niveau eller placeres på et sted, hvor der ophobes vand.

ND N.B.: Under installasjon av apparatet, unngå å skjule basen eller plassere den på områder som er utsatt for damp.

SV OBS! När utrustningen installeras ska du undvika att basen hamnar under marken eller placeras på ställen där vatten ansamlas.

RU ПРИМЕЧАНИЕ: При монтаже прибора следует избегать закрывать его базу или устанавливать его в местах, подверженных застою воды.

ZH 注意: 安装该灯具时, 避免隐藏底座或将灯具放置在易受潮的区域。

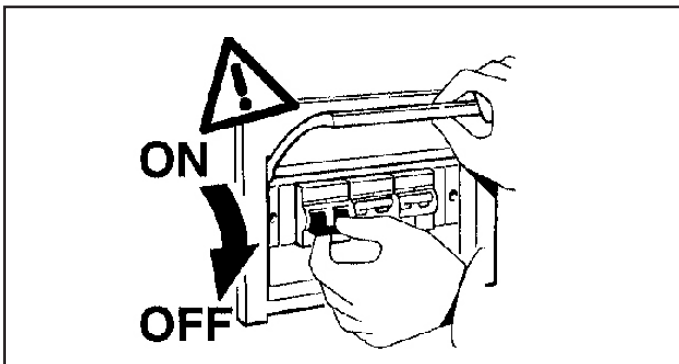

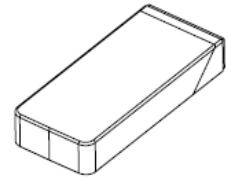
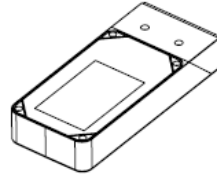
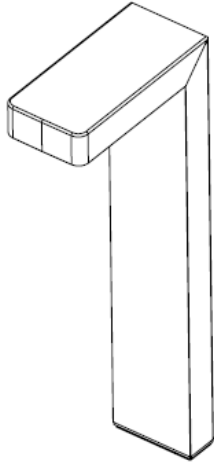
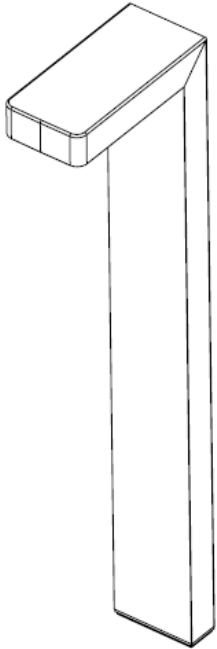

AKU1  
AKU2  
ALS4  
ALS5  
ALS6  
ALS7

AKS9  
AKT0  
ALS0  
ALS1  
ALS2  
ALS3

AKS7  
AKS8  
ALS8  
ALS9

AKS3  
AKS4  
ALW0  
ALW1

AKS5  
AKS6  
ALW2  
ALW3

IT	PESO, DIMENSIONI E SUPERFICIE DELLA COMPOSIZIONE DI MASSIMO INGOMBRO.
EN	WEIGHT, DIMENSIONS AND SURFACE AREA OF THE LARGEST COMPOSITION.
FR	POIDS, DIMENSIONS ET SURFACE DE LA COMPOSITION D'ENCOMBREMENT MAXIMUM.
DE	GEWICHT, ABMESSUNGEN UND OBERFLÄCHE DER ZUSAMMENSTELLUNG MIT DEM GRÖßTEN RAUMBEDARF.
NL	GEWICHT, AFMETINGEN EN OPPERVLAKTE VAN DE SAMENSTELLING MET DE MEESTE PLAATSRUIMTE.
ES	PESO, DIMENSIONES Y SUPERFICIE DE LA COMPOSICIÓN DE MÁXIMO VOLUMEN.
DA	VÆGT, DIMENSIONER OG SAMLET OVERFLADEMÅL PÅ SAMMENSÆTTNINGEN.
ND	VEKT, DIMENSJONER OG OVERFLATE PÅ DEN STØRSTE SAMMENSETNINGEN.
SV	VIKT, MÅ...TT OCH YTA FÅ-R UTFÅ-RANDE MED MAX. YTTRE MÅ...TT.
RU	ВЕС, ГАБАРИТНЫЕ РАЗМЕРЫ И МАКСИМАЛЬНАЯ ЗАНИМАЕМАЯ ПЛОЩАДЬ КОНСТРУКЦИИ
ZH	组件的最大重量, 尺寸及面积。

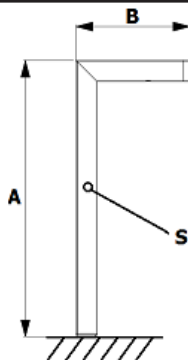

ART.	PESO WEIGHT POIDS GEWICHT GEWICHT PESO VÆGT VEKT VIKT BEC 重量 ( Kg )	Dimensioni Dimensions Dimensions Abmessungen Afmetingen Dimensiones - Mål Mål - Mått Размеры 尺寸 a x b (mm)	Superficie Surface Surface Oberfläche Oppervlak Superficie Overflade Overflate Yta Поверхность 面积 (mq)
AKU1 - AKU2 - ALS4 ALS5 - ALS6 - ALS7	8,1	950X271	0,41
AKS9 - AKT0 - ALS0 ALS1 - ALS2 - ALS3	5,8	650X271	0,3

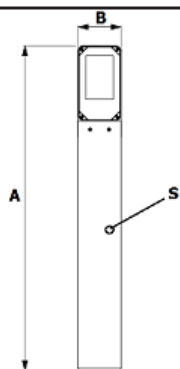

ART.	PESO WEIGHT POIDS GEWICHT GEWICHT PESO VÆGT VEKT VIKT BEC 重量 ( Kg )	Dimensioni Dimensions Dimensions Abmessungen Afmetingen Dimensiones - Mål Mål - Mått Размеры 尺寸 a x b (mm)	Superficie Surface Surface Oberfläche Oppervlak Superficie Overflade Overflate Yta Поверхность 面积 (mq)
AKS7 - AKS8 ALS8 - ALS9	6,8	950X126	0,33

ART.	PESO WEIGHT POIDS GEWICHT GEWICHT PESO VÆGT VEKT VIKT BEC 重量 ( Kg )	Dimensioni Dimensions Dimensions Abmessungen Afmetingen Dimensiones - Mål Mål - Mått Размеры 尺寸 a x b (mm)	Superficie Surface Surface Oberfläche Oppervlak Superficie Overflade Overflate Yta Поверхность 面积 (mq)
AKS3 - AKS4 - AKS5 - AKS6 ALW0 - ALW1 - ALW2 - ALW3	2,8	290X126	0,1



- IT **N.B.:** Per il collegamento elettrico alla rete, servirsi dell'art. **X188** o di altri dispositivi di connessione in classe II che garantiscano il grado di protezione IP66.
- EN **N.B.:** For connection to the mains electricity supply, use item **X188** or other Class II connection devices which offer the IP66 degree of protection.
- FR **N.B.:** Pour le raccordement électrique au secteur, utiliser l'art **X188** ou tout autre dispositif de connexion en classe II assurant un indice de protection IP66.
- DE **N.B.:** Für den elektrischen Anschluss verwenden Sie den Art. **X188** oder andere Anschlussvorrichtungen der Klasse II, die den Schutzgrad IP66 gewährleisten.
- NL **N.B.:** Voor de aansluiting op het elektrische net moet u gebruik maken van het art. **X188** of van andere verbindingsapparaten van klasse II, die een beschermingsgraad IP66 garanderen.
- ES **N.B.:** Para la conexión eléctrica a la red, consultar el Art. **X188** o emplear otros dispositivos de conexión en la clase II que garantizan el grado de protección IP66.
- DA **N.B.:** For elektrisk kobling til nettet, brug art. **X188** eller andre koblingsanordninger i klasse II som sikrer vernegrad IP66.
- ND **N.B.:** For elektrisk tilslutning til forsyningsnettet skal man bruge art. **X188** eller en anden forbindelsesanordning i klasse II, der garanterer en beskyttelsesgrad lig med IP66.
- SV **OBS!** För anslutningen till elnätet, använd art. **X188** eller andra anslutningsanordningar i klass II som garanterar skyddsgrad IP66.
- RU **ПРИМЕЧАНИЕ:** Для подключения электрической сети используйте артикул **X188** или другие устройства защиты от поражения электрическим током с степенью защиты IP66.
- ZH **注意事项:** 对于电力网络连接, 需要 **X188** 产品或者其他可以确保IP66保护等级的连接设备。



IT PER IL FISSAGGIO SI CONSIGLIA DI UTILIZZARE TASSELLI PER ANCORAGGI PESANTI TIPO FZA- I- + 8 FISCHER, O SIMILARI ANCHE DI ALTRI COSTRUTTORI.  
EN FOR FIXING USE HEAVY DUTY PLUGS, SUCH AS FZA- I- + 8 FISCHER OR SIMILAR, INCLUDING FROM OTHER MANUFACTURERS.  
FR POUR LA FIXATION, IL EST CONSEILLÉ D'UTILISER DES CHEVILLES POUR ANCRAGES LOURDS DE TYPE FZA- I- M 6 + 8 FISCHER OU SIMILAIRES (D'AUTRES FABRICANTS AUSSI) .  
DE ZUR BEFESTIGUNG EMPFEHLEN WIR, STARKE VERANKERUNGSDÜBEL ZU VERWENDEN, ZUM BEISPIEL VOM TYP FZA-I- + 8 VON FISCHER ODER ENTSPRECHENDE PRODUKTE VON ANDEREN HERSTELLERN.  
NL VOOR DE BEVESTIGING RADEN WIJ U AAN PLUGGEN VOOR ZWARE VERANKERINGEN TE GEBRUIKEN, ZOALS HET TYPE FZA- I- + 8 FISCHER OF DERGELIJKE, OOK VAN ANDERE PRODUCTEN.  
ES PARA LA FIJACIÓN SE RECOMIENDA UTILIZAR TACOS PARA ANCLAJES DE GRAN RESISTENCIA, TIPO FZA-I- + 8 FISCHER, O SIMILARES, INCLUSO DE OTROS FABRICANTES.  
DA VED MONTERING ANBEFALES BRUG AF RAWLPLUGS TIL TUNGE EMNER AF TYPEN FZA- I- + 8 FISCHER, ELLER LIGNENDE FRA ANDRE FABRIKANTER.  
ND FOR FESTE BRUKES HØYYTELSES PLUGGER, SLIK SOM FZA - I- + 8 FISCHER ELLER LIGNENDE, INKLUDERT FRA ANDRE PRODUSENTER.  
SV FÖR FASTSÄTTNINGEN REKOMMENDERAS ATT ANVÄNDA PLUGGAR FÖR FASTSÄTTNING AV TYNGRE FÖREMÅL AV TYP FZA- I- + 8 FISCHER, ELLER LIKANDE AV ANNAT MÄRKE.

## OSUHAUSUI ÄOSUI ÄOSUI ÄOSUI ÄOSY €ÄOSY FÄOSY GÄOSY H

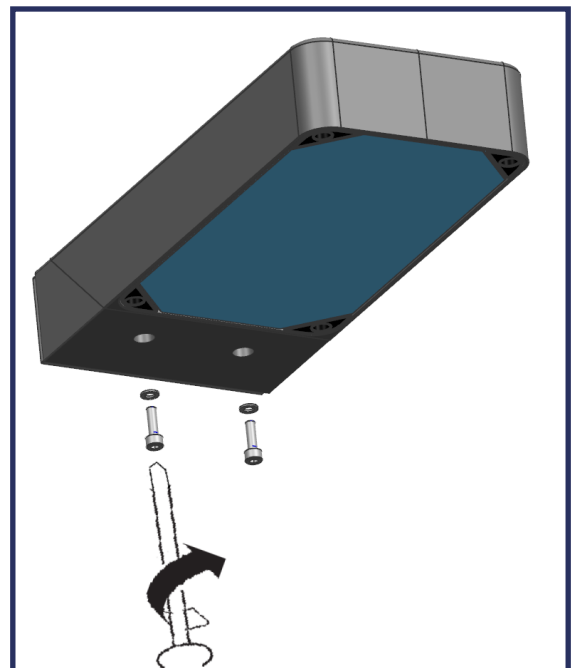
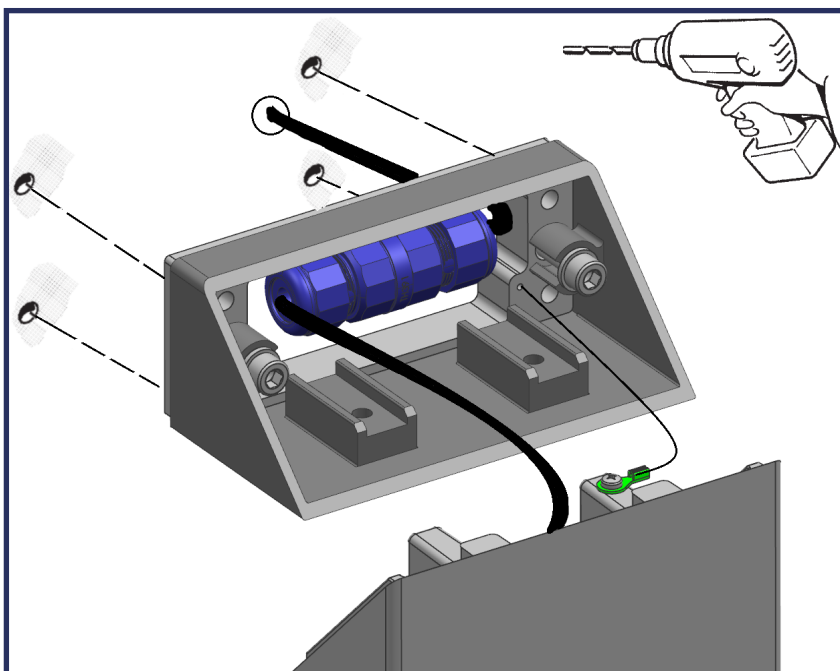
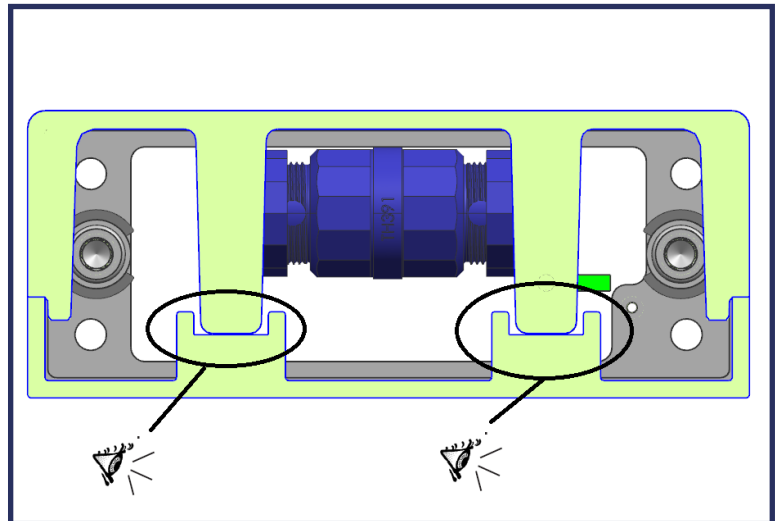
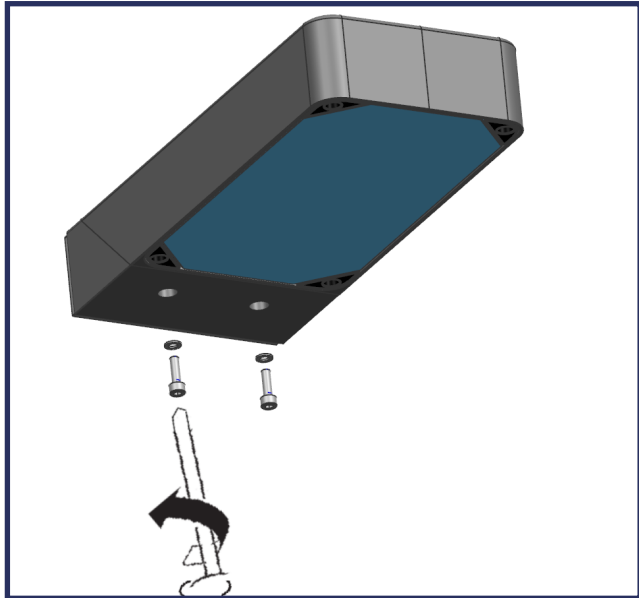
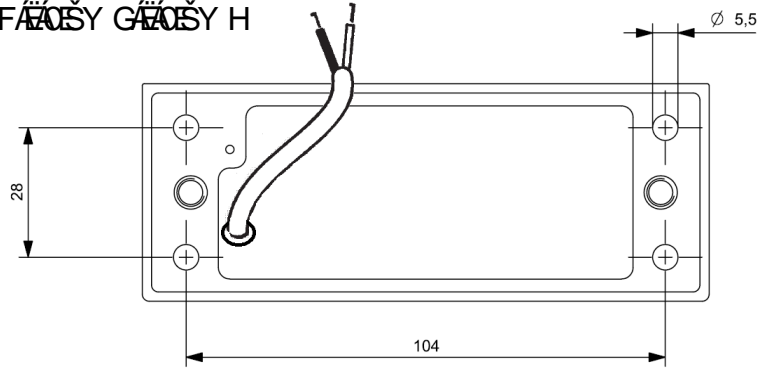
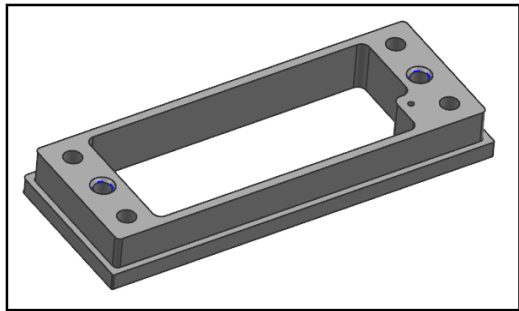

- 1 - L
- 2 - N
- 3 - DA
- 4 - DA

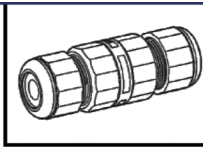

1,5 ÷ 2 Nm

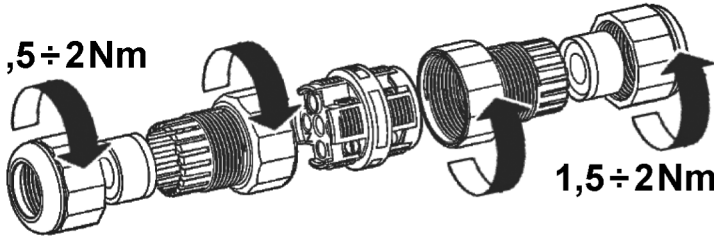

1,5 ÷ 2 Nm

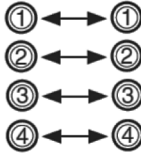

MAX 4 mm<sup>2</sup>

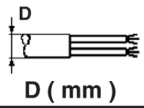
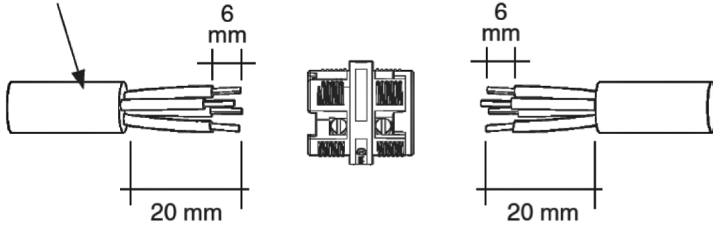

2,5 ÷ 3,5 mm



1,5 ÷ 2 mm



2,5 ÷ 3 mm



1,5 ÷ 2 mm

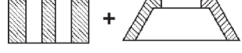

5,5 ÷ 7 mm



4,5 ÷ 6,5 mm



2,5 ÷ 3 mm



1,5 ÷ 2 mm



5 ÷ 7 mm



7 ÷ 9 mm

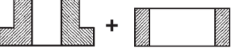

9 ÷ 12 mm



ALW0 - ALW1 - ALW2 - ALW3



+





IT PER IL FISSAGGIO SI CONSIGLIA DI UTILIZZARE TASSELLI PER ANCORAGGI PESANTI TIPO FZA-I- 8 FISCHER, O SIMILARI ANCHE DI ALTRI COSTRUTTORI.  
 EN FOR FIXING USE HEAVY DUTY PLUGS, SUCH AS FZA-I- 8 FISCHER OR SIMILAR, INCLUDING FROM OTHER MANUFACTURERS.  
 FR POUR LA FIXATION, IL EST CONSEILLÉ D'UTILISER DES CHEVILLES POUR ANCRAGES LOURDS DE TYPE FZA-I-M 6 + 8 FISCHER OU SIMILAIRES (D'AUTRES FABRICANTS AUSSI) .  
 DE ZUR BEFESTIGUNG EMPFEHLEN WIR, STARKE VERANKERUNGSDÜBEL ZU VERWENDEN, ZUM BEISPIEL VOM TYP FZA-I- 8 VON FISCHER ODER ENTSPRECHENDE PRODUKTE VON ANDEREN HERSTELLERN.  
 NL VOOR DE BEVESTIGING RADEN WIJ U AAN PLUGGEN VOOR ZWARE VERANKERINGEN TE GEBRUIKEN, ZOALS HET TYPE FZA-I- 8 FISCHER OF DERGELIJKE, OOK VAN ANDERE PRODUCENTEN.  
 ES PARA LA FIJACIÓN SE RECOMIENDA UTILIZAR TACOS PARA ANCLAJES DE GRAN RESISTENCIA, TIPO FZA-I- 8 FISCHER, O SIMILARES, INCLUSO DE OTROS FABRICANTES.  
 DA VED MONTERING ANBEFALES BRUG AF RAWLPLUGS TIL TUNGE EMNER AF TYPEN FZA-I- 8 FISCHER, ELLER LIGNENDE FRA ANDRE FABRIKANTER.  
 ND FOR FESTE BRUKES HØYYTELSES PLUGGER, SLIK SOM FZA-I- 8 FISCHER ELLER LIGNENDE, INKLUDERT FRA ANDRE PRODUSENTER.  
 SV FÖR FASTSÄTTNINGEN REKOMMENDERAS ATT ANVÄNDA PLUGGAR FÖR FASTSÄTTNING AV TYNGRE FÖREMÅL AV TYP FZA-I- 8 FISCHER, ELLER LIKANDE AV ANNAT MÄRKE.

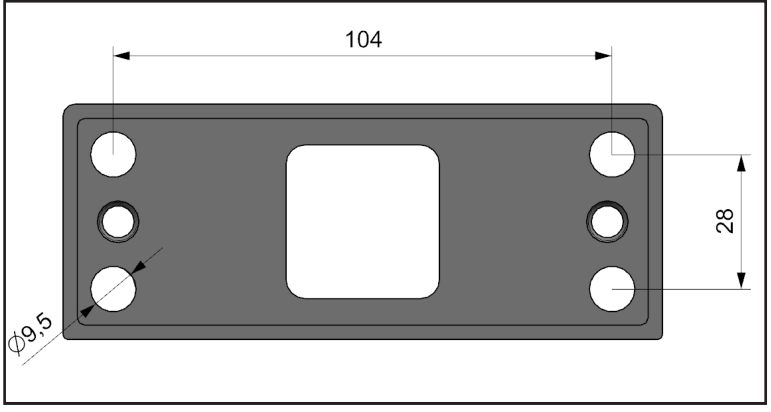
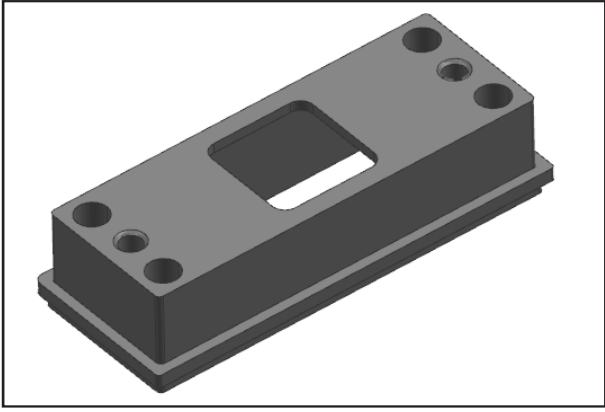

AKS9 - AKT0 - AKU1  
 AKU2 - AKS7 - AKS8  
 ALS0 - ALS1 - ALS2  
 ALS3 - ALS4 - ALS5  
 ALS6 - ALS7 - ALS8  
 ALS9

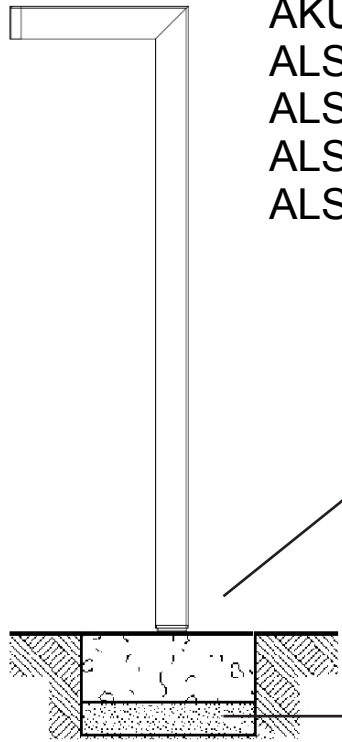

CALCESTRUZZ  
 O CONCRETE  
 BETON  
 BETON  
 CEMENT  
 HORMIGÓN  
 RMIGÓN  
 BETON  
 BETONG  
 BETONG  
 БЕТОН  
 混凝土

GHIAIA PER DRENAGGIO  
 GRAVEL LAYER FOR  
 DRAINAGE GRAVIER DE  
 DRAINAGE  
 KIES FÜR DIE DRAINAGE  
 GRINT VOOR DRAINAGE  
 GRAVILLA PARA DRENAJE  
 GRUS TIL DRÆNING  
 KISLAG FOR TØMMING  
 DRÄNERINGSGRUS  
 ДРЕНАЖНЫЙ ГРАВИЙ  
 排水砂砾层

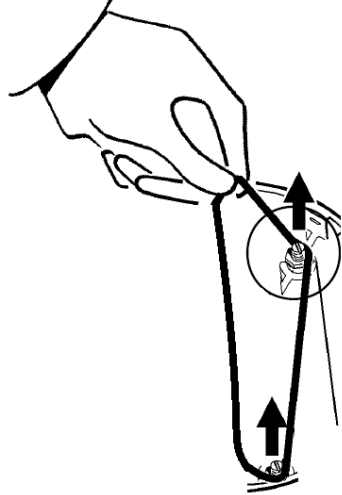

IT Prima di utilizzare il prodotto asportare gli elastici.  
 EN Remove the elastic bands before using the product.  
 FR Enlevez les élastiques avant d'utiliser le produit.  
 DE Bevor Sie das Produkt verwenden, entfernen Sie die Gummis.  
 NL Voordat u het product gaat gebruiken moeten de elastieken verwijderd worden.  
 ES Remover los elásticos antes de utilizar el producto.  
 DA Fjern elastikbåndene inden produktet tages i brug.  
 ND Fjern de elastiske båndene før bruk av produktet.  
 SV Ta bort gummisnoddarna innan utrustningen används.  
 RU Перед началом эксплуатации прибора снимите с него резинки.  
 ZH 在使用产品之前先取下弹性木梢。

AKS7 - AKS8 - ALS8 - ALS9

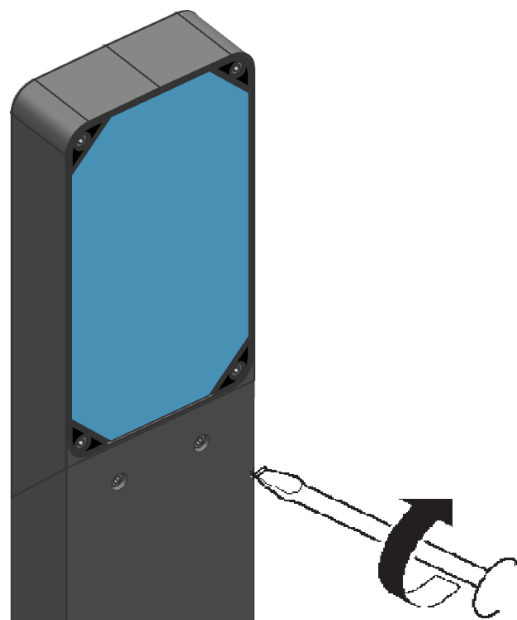
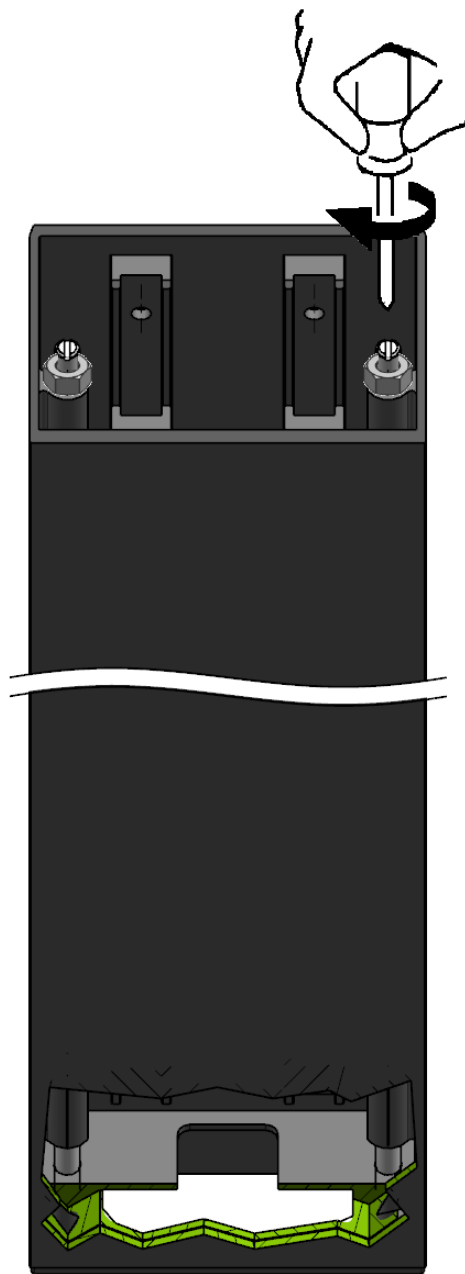
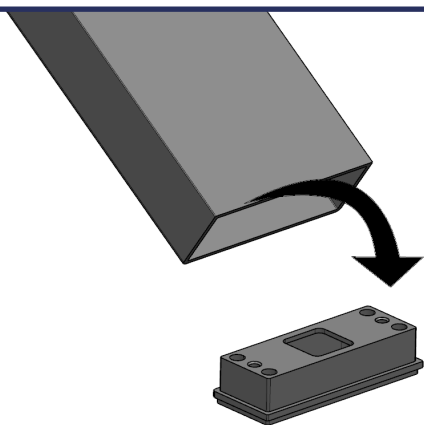
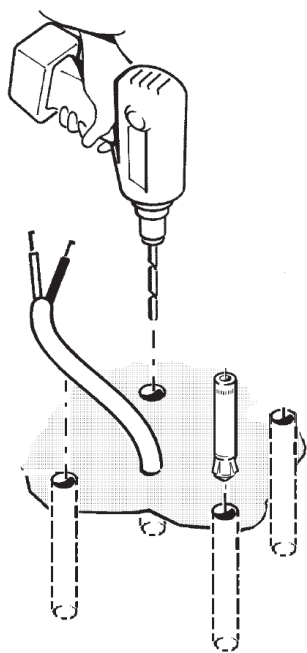
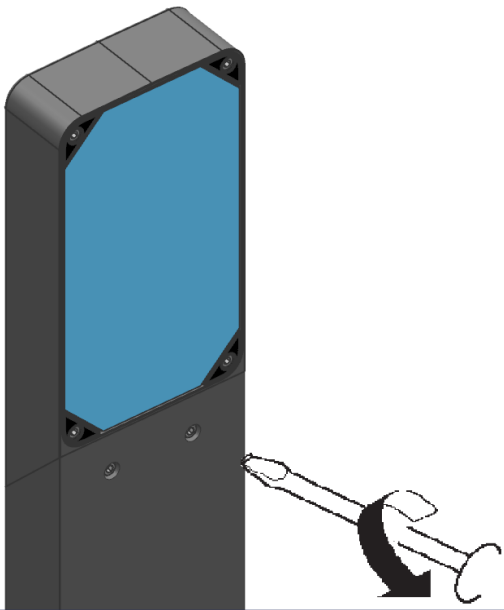

AKS9-AKT0-AKU1-AKU2  
ALS0-ALS1-ALS2-ALS3  
ALS4-ALS5-ALS6-ALS7

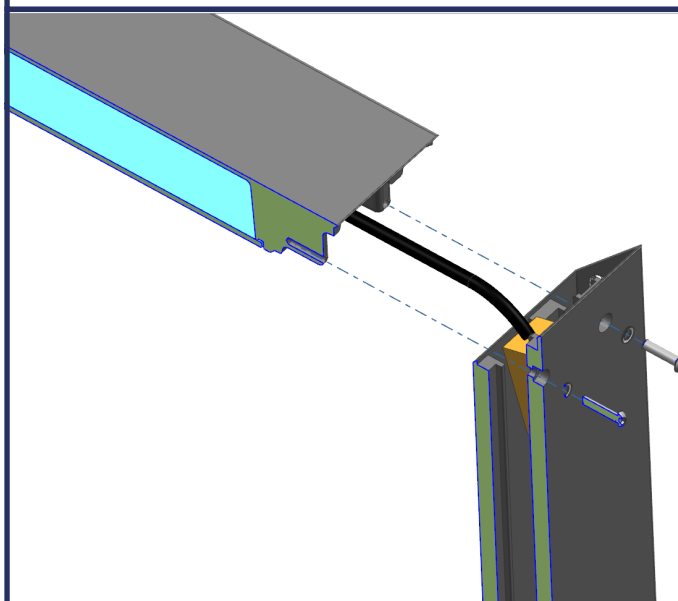
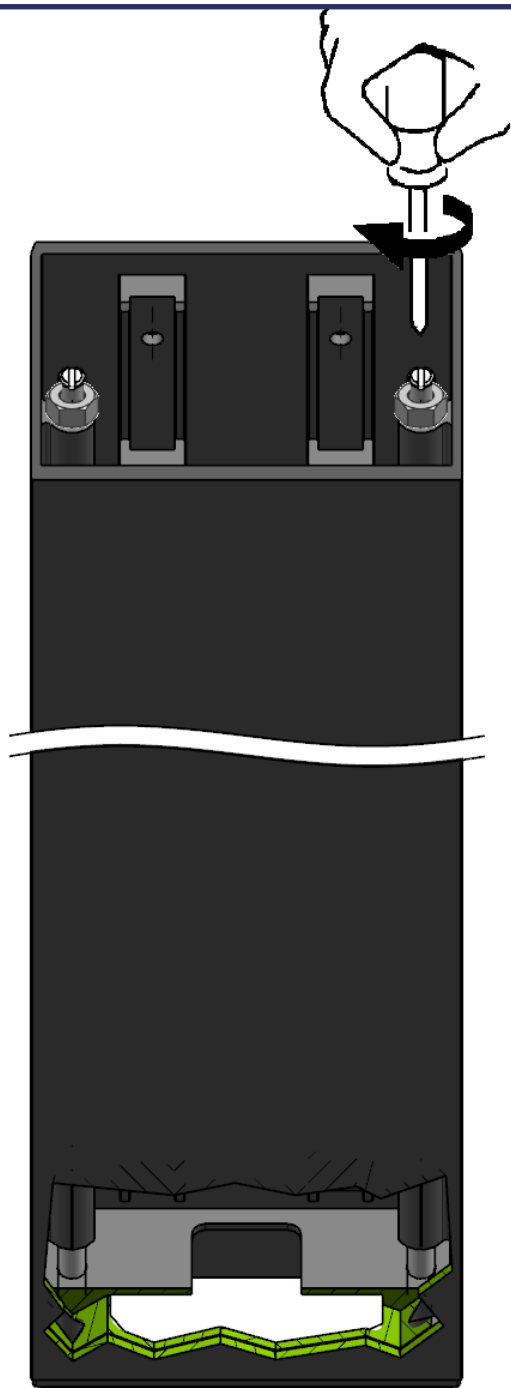
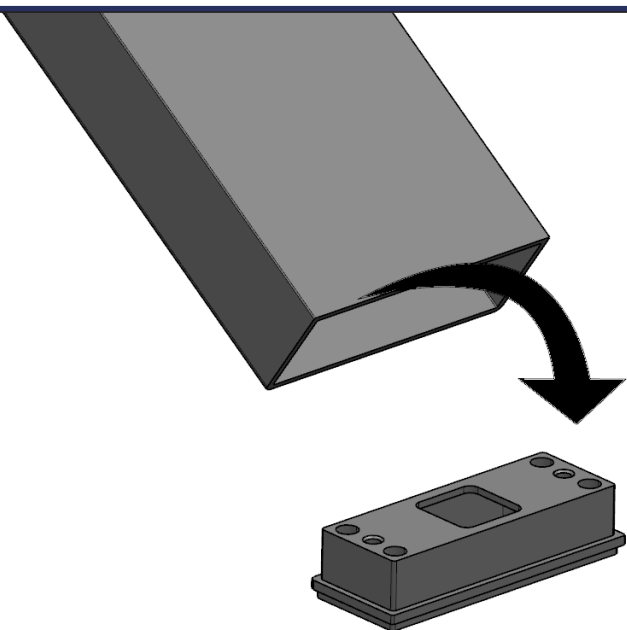
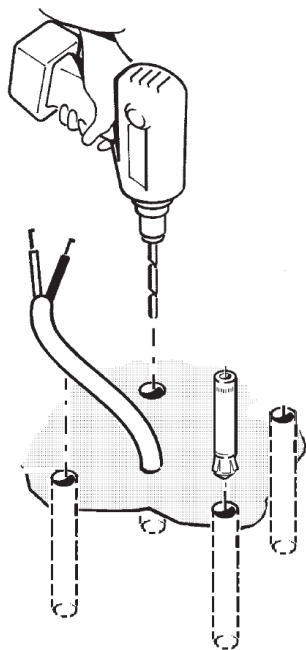



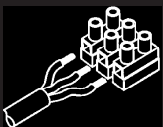

AKS9 - AKT0 - AKU1 - AKU2 - AKS7 - AKS8 - ALS0 - ALS4

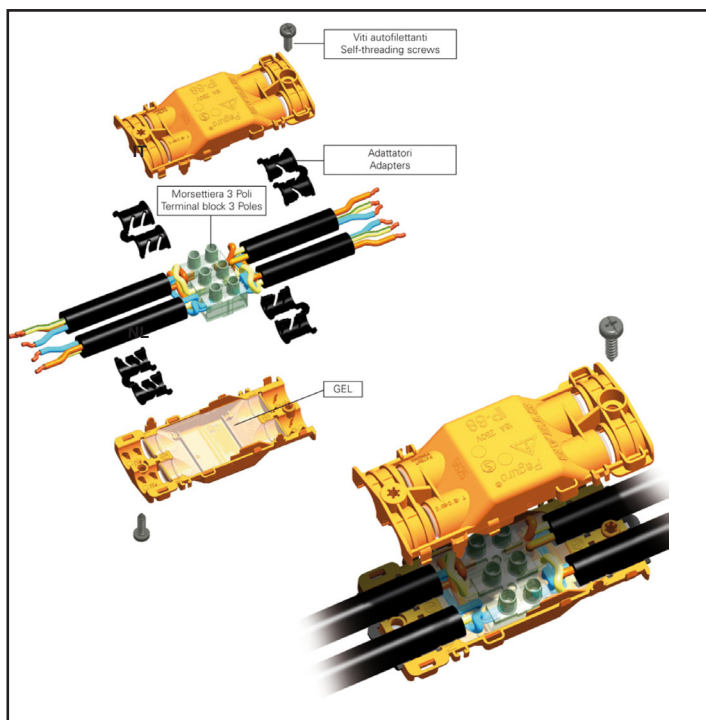

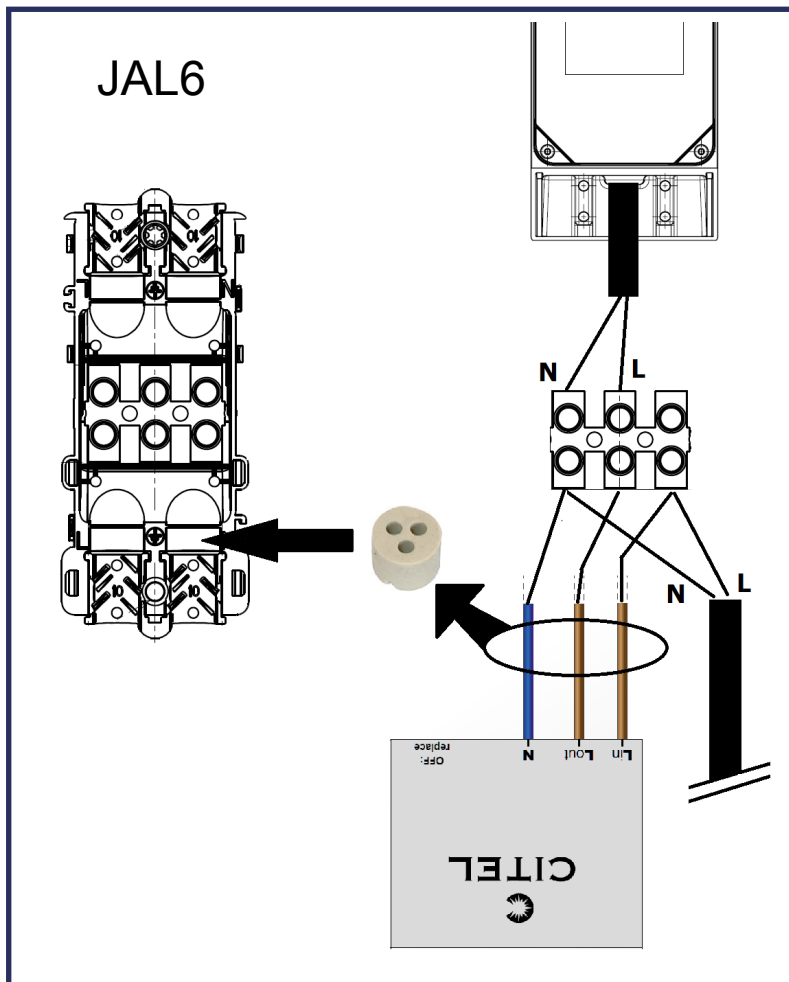

<p><b>Posizione cavo</b></p> <p><b>min.6</b></p>	<p><b>Schema sguainatura cavo</b></p>
<p>Morsettiera 3x4 mm<sup>2</sup>          Per cavi tondi <math>\varnothing_{est} D = \text{min } 9.5 - \text{max } 12</math>  <math>\text{min } 6.5 - \text{max } 9.5</math> con adattatori</p>	

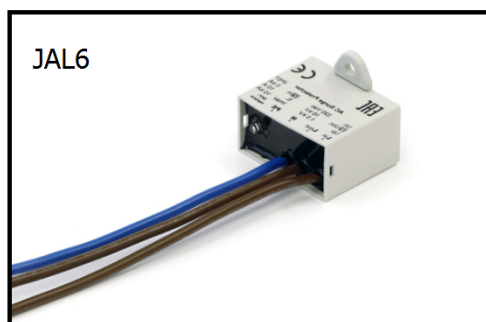
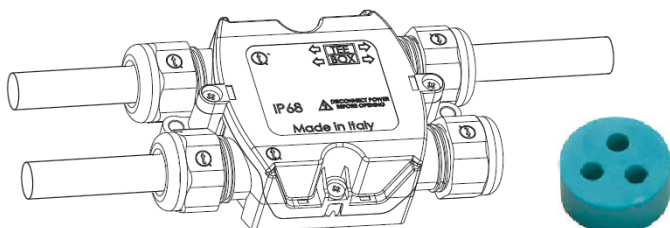
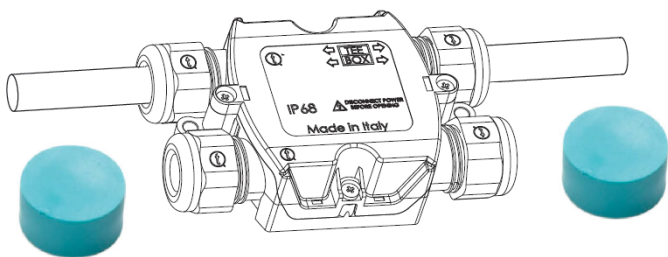
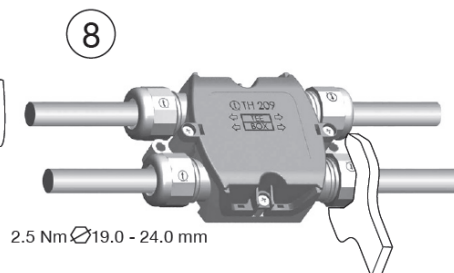
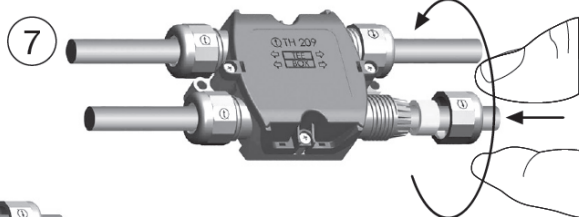
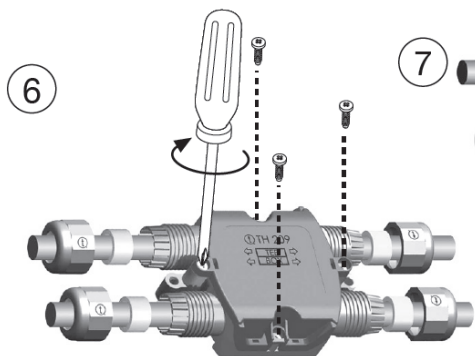
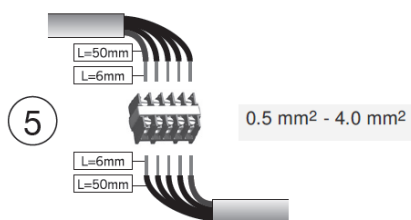
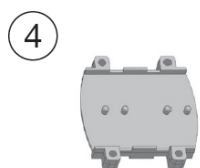
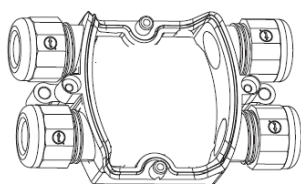
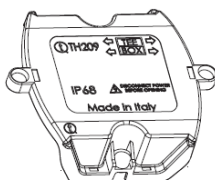
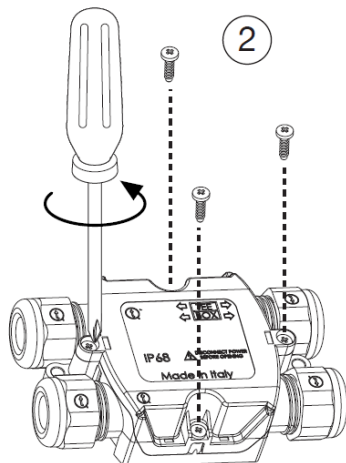
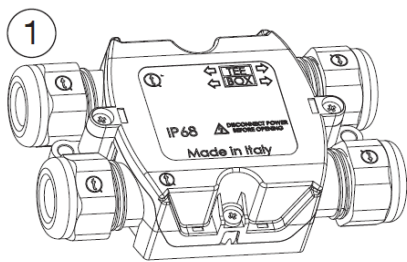

# ALS1 - ALS2 - ALS3 - ALS5 - ALS6 - ALS7 - ALS8 - ALS9

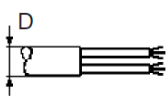
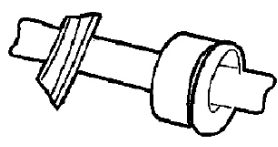
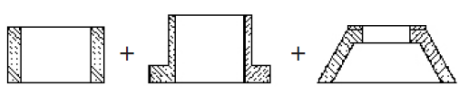
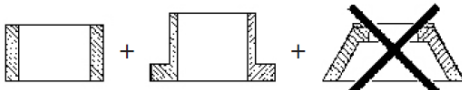

 <p>D ( mm )</p>	
6 ÷ 7 mm	
7 ÷ 9 mm	
9 ÷ 13,5 mm	

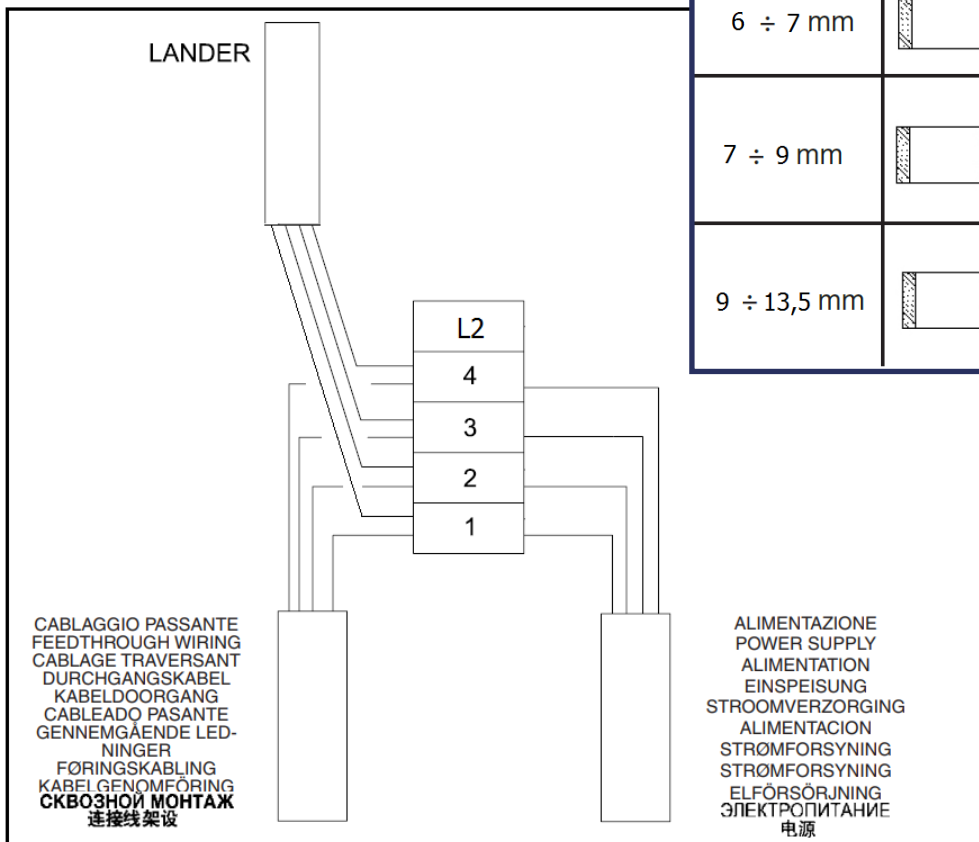

- 1 - L
- 2 - N
- 3 - DA
- 4 - DA
- L2 - PROTECTED LINE

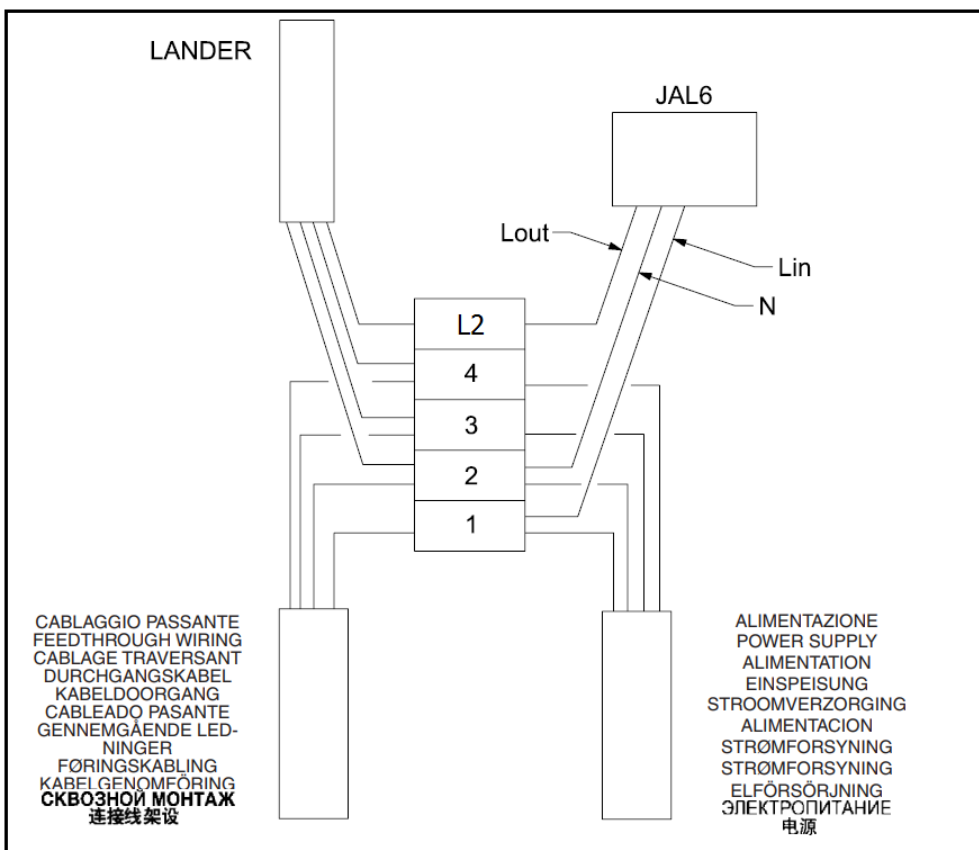

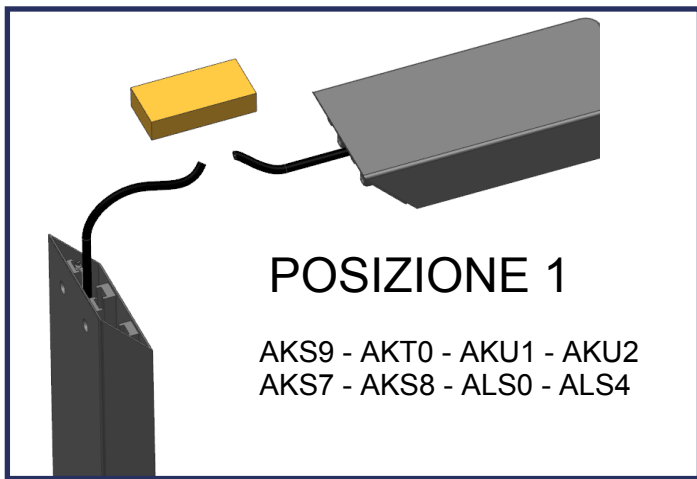

## POSIZIONE 1

AKS9 - AKT0 - AKU1 - AKU2  
AKS7 - AKS8 - ALS0 - ALS4

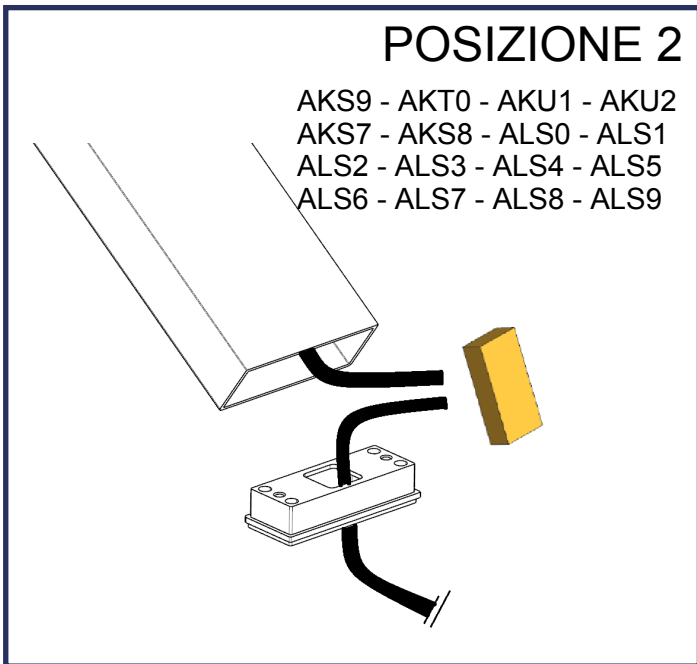

## POSIZIONE 2

AKS9 - AKT0 - AKU1 - AKU2  
AKS7 - AKS8 - ALS0 - ALS1  
ALS2 - ALS3 - ALS4 - ALS5  
ALS6 - ALS7 - ALS8 - ALS9

IT Per il cablaggio elettrico utilizzare cavi con doppio isolamento.  
EN Use cable with double insulation for the electric wiring.  
FR Pour le câblage électrique, utiliser des câbles à double isolation.  
DE Für die elektrische Verdrahtung sind Kabel mit Mantel zu verwenden.  
NL Gebruik dubbel-geïsoleerde kabels voor de elektrische aansluiting.  
ES Para el cableado eléctrico servirse de cables con doble aislamiento.  
DA De anvendte ledninger skal have dobbelt isolering.  
ND Bruk kabel med dobbelt isolasjon til elektrisk kabling.  
SV Använd elkablar med dubbel isolering för kabeldragnigen.  
RU Для монтажа кабелепроводки используйте провода с двойной изоляцией.  
ZH 针对架线，使用双重绝缘的电缆。

IT In caso di danneggiamento del cavo flessibile esterno, questo deve essere sostituito dal costruttore, o dal suo servizio di assistenza, o da personale qualificato equivalente, al fine di evitare pericoli.  
EN Should the outer flexible cable be somehow damaged, the latter should be replaced by the manufacturer, or by the corresponding service centre, or by an appropriate and qualified member of staff in order to avoid all risk of danger.  
FR Si le câble flexible extérieur est abîmé, faites-le remplacer par le fabricant, par son service après-vente ou par un professionnel du secteur agréé afin d'éviter tout danger.  
DE Sollte das äußere Kabel beschädigt sein, so muss es aus Sicherheitsgründen vom Hersteller, dessen Kundendienst oder von dazu autorisiertem Personal ausgewechselt werden.  
NL Mocht de externe flexibele slang beschadigd worden, dan moet deze worden vervangen door de fabrikant of door een bevoegde installateur, zodat eventueel gevaar vermeden wordt.  
ES En caso de daños el cable flexible externo debe substituirse por el fabricante, su servicio de asistencia o personal calificado equivalente para evitar peligros.  
DA Hvis den yderste ledning beskadiges, skal den udskiftes af producenten eller et autoriseret teknisk servicecenter, eller af kvalificerede fagfolk, så man undgår farlige situationer.  
ND Hvis ytre fleksible kabel skulle bli skadet, skal denne skiftes ut av produsenten eller tilsvarende servicecenter eller av en egnet og kvalifisert fagperson for å unngå farerisiko.  
SV Om den ytre kabeln skadas ska den bytas ut av tillverkaren, av dess auktoriserade verkstad eller av likvärdig kvalificerad personal för att undvika alla typer av risker.  
RU В случае повреждения внешнего гибкого кабеля во избежание риска поручите его замену производителю, уполномоченному сервису или квалифицированному электрику.  
ZH 如果外部软缆损坏，须由生产商、对应服务中心或能胜任和资深的员工更换新的电缆，以避免任何可能的危险。

IT Calcolare il numero massimo dei prodotti collegabili in cascata, tenendo conto dell'assorbimento dei prodotti, della sezione dei cavi, della lunghezza dei cavi e della corrente max dei connettori.  
EN Calculate the maximum number of products connectable in cascade based on products' consumption, connectors' maximum current, cables' section and length.  
FR Calculer le nombre maximum de produits raccordables en cascade en tenant compte de la puissance absorbée par les luminaires, de la section et de la longueur des câbles ainsi que du courant maximum des connecteurs.  
DE Die maximale Anzahl der in Kaskadenschaltung anschließbaren Produkte unter Berücksichtigung der Leistungsaufnahme der Produkte, Kabeldurchmesser und -länge sowie des max. Stroms der Verbinder berechnen.  
NL Bereken het maximale aantal producten dat in cascadevolgorde kan worden aangesloten. Houd rekening met de stroomopnamen van de producten, van de kabeldiameter, de lengte van de kabels en van de max stroom van de connectoren.  
ES Calcular el número máximo de productos conectables en cascada, teniendo en cuenta la absorción de los productos, la sección de los cables, la longitud de los cables y la corriente máxima de los conectores.  
DA Beregn det maksimale antal produkter, der kan tilsluttes på række, idet der tages højde for produkternes strømoptag, kablernes tværsnit og længde samt stikkernes maksimale strømstyrke.  
ND Beregne maksimalt antall produkter som kan kaskadekobles. Ta med i betraktningen produktenes strømopptak, ledningenes tverrsnitt og lengde, samt koblingsstykkenes toppstrøm.  
SV Beräkna max. antal produkter som kan kaskadkopplas genom att ta hänsyn till produkternas strömförbrukning, kablarnas tvärsnitt och längd, samt kontaktarnas max. ström.  
RU Рассчитать максимальное число последовательно подсоединяемых изделий, учитывая поглощение изделий, сечение и длину проводов и макс. ток разъемов.  
ZH 根据产品的能耗、连接端的最大电流、电缆的截面大小和长度，计算出可并列连接的最多产品数。

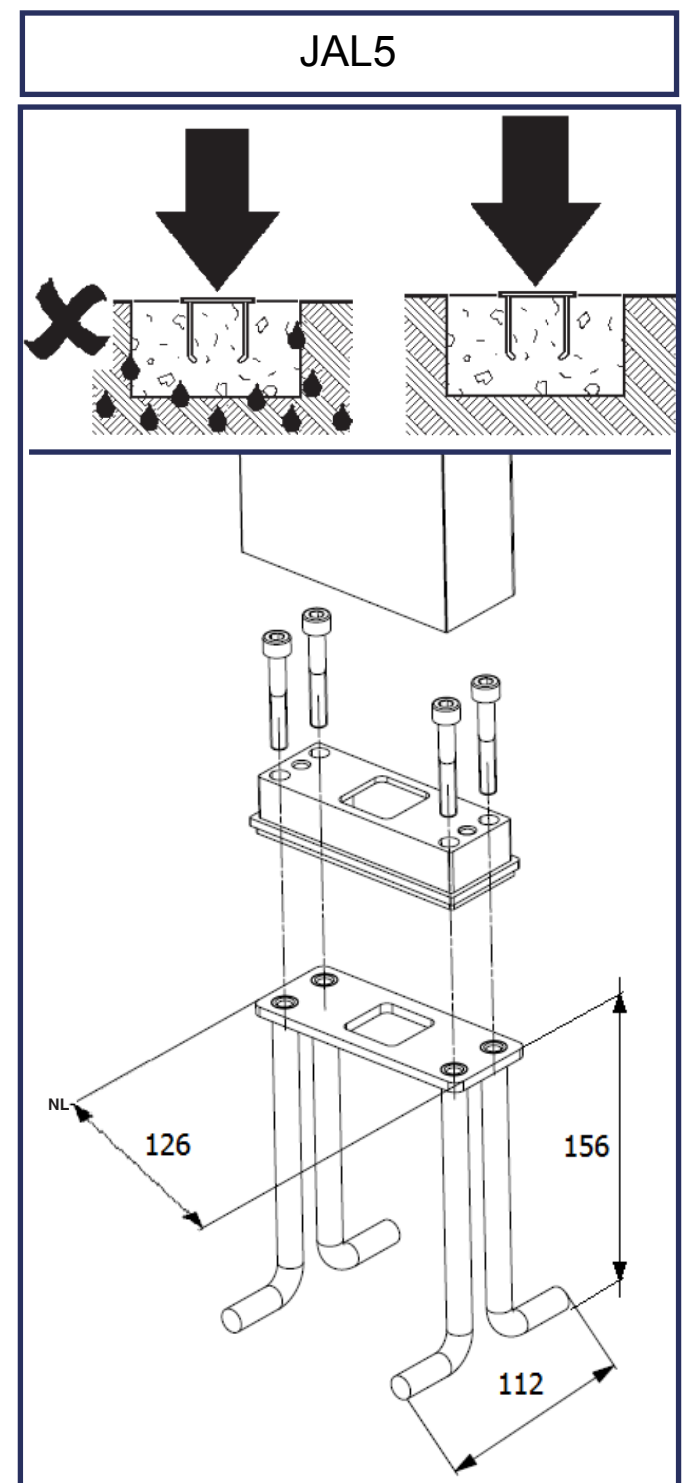



IT In caso di rottura del vetro il prodotto non può essere utilizzato, contattare il costruttore per la sua sostituzione.

EN Should the glass break, the product cannot be used and you should contact the manufacturer for its replacement.

FR En cas d'endommagement de l'écran de protection le produit ne peut pas être utilisé, contactez le fabricant pour le remplacement.

DE Falls das Glas kaputt sein sollte, kann das Produkt nicht verwendet werden. Kontaktieren Sie in dem Fall den Hersteller, um das Glas zu ersetzen.

NL Als het glas gebroken is kan het apparaat niet worden gebruikt en moet u zich tot de fabrikant wenden voor het vervangen van het glas.

ES No utilizar el producto en caso de ruptura del vidrio y contactar el fabricante para la sustitución.

DA Hvis produktets glas ødelægges, kan det ikke anvendes. Kontakt forhandleren med henblik på udskiftning.

ND Hvis glasset skulle knuses, kan ikke produktet brukes, og du må ta kontakt med produsenten for å få det skiftet.

SV Om glaset går sönder kan inte produkten användas. Kontakta tillverkaren för att byta ut glaset.

RU В случае разбивания стекла не использовать прибор, обратиться к его производителю для замены.

ZH 一旦玻璃破碎后产品将不能再使用，须联系生产商予以更换。

IT **N.B.:** Per la sostituzione del LED contattare l'azienda iGuzzini.

EN **N.B.:** For information on LED replacement please contact iGuzzini.

FR **N.B.:** Pour procéder au remplacement de la LED, adressez-vous à la société iGuzzini.

DE **N.B.:** Bezüglich des Austausches der LED kontaktieren Sie bitte die Firma iGuzzini.

NL **N.B.:** Voor het vervangen van de LED neemt u contact op met het bedrijf iGuzzini.

ES **NOTA:** Para sustituir el LED llame a la empresa iGuzzini.

DA **N.B.:** For udskiftning af lysdioden, skal man kontakte iGuzzini.

ND **N.B.:** For informasjon om skifte av LED, vennligst ta kontakt med iGuzzini.

SV **OBS!** För byte av lysdioden, kontakta företaget iGuzzini.

RU **ПРИМЕЧАНИЕ:** Для замены СИДов обращайтесь в компанию iGuzzini.

ZH **注意:** 如需LED更换的信息，请联系iGuzzini。

CARICO DALI / DALI LOAD CHARGE DALI (COURANT MAXI ADMISSIBLE) DALI-LAST DALI VERMOGEN CARGA DALI DALI STRØMSTYRKE BELASTNING FOR "DALI" DALI-BELASTNING МАКС. ТОК СИСТЕМЫ DALI С РЕГУЛЯЦИЕЙ ИНТЕНСИВНОСТИ СВЕТА DALI 智能调光系统允许的最大电流量	INDIRIZZI DALI DALI ADDRESSES ADRESSES DALI DALI-ADRESSEN DALI ADRESSEN DIRECCIONES DALI DALI ADDRESSER ADRESSER TIL "DALI" DALI-ADRESSER ЛОГИЧЕСКИЕ АДРЕСА СИСТЕМЫ DALI DALI智能调光系统计算机指定控制参数
1 (2 mA)	1

IT Il prodotto è conforme allo standard DALI, con riferimento alle norme EN 62386-101, EN62386-102, EN62386-207.

The product complies with the DALI standard, with reference to the EN 62386-101, EN 62386-102 and EN 62386-207 standards.

Le produit est conforme à la norme DALI, repris dans les documents EN 62386-101, EN62386-102, EN62386-207.

Das Produkt erfüllt den DALI-Standard unter Bezugnahme auf die Normen EN 62386-101, EN62386-102, EN62386-207.

Het product voldoet aan de DALI-standaard, verwijzend naar de normen EN 62386-101, EN62386-102, EN62386-207.

El producto es conforme al estándar DALI, con referencia a las normas EN 62386-101, EN62386-102, EN62386-207.

Produktet stemmer overens med DALI-standarden med henvisning til standarderne EN 62386-101, EN62386-102, EN62386-207.

Produktet er i samsvar med DALI-standarden i henhold til standardene NEK-EN 62386-101, NEK-EN-62386-102, NEK-EN-62386-207.

Produkten överensstämmer med DALI-standarden, med hänvisning till standarderna EN 62386-101, EN62386-102, EN62386-207.

Товар отвечает стандарту DALI, со ссылкой на стандарты EN 62386-101, EN62386-102, EN62386-207.

该产品符合数字寻址灯控接口 (DALI) 标准，并且参考 EN 62386-101、EN 62386-102 和 EN 62386-207 标准。

**iGuzzini**

ART.	fattore di potenza power factor facteur de puissance Leistungsfaktor vermogensfactor factor de potencia effektfaktor effektfaktor effektfaktor фактор мощности 功率因数	corrente assorbita absorbed current courant absorbé Stromaufnahme stroomopname corriente absorbida absorberet strøm absorbert strøm tillförd ström поглощаемая мощность 电源电流 (A)
AKS9 - AKU1 - AKT0 - AKU2 ALS2 - ALS6 - ALS3 - ALS7	0,86	0,06
ALS0 - ALS4 - ALS1 - ALS5	0,82	0,05
ALW2 - ALW3 - AKS5 - AKS6	> 0,9	0,07
ALS8 - ALS9 - AKS7 - AKS8	> 0,9	0,08
ALW0 - ALW1 - AKS3 - AKS4	> 0,9	0,11

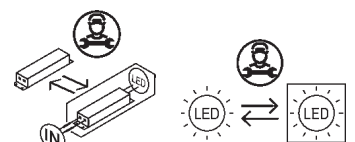

Headquarters iGuzzini illuminazione spa  
via Mariano Guzzini, 37 - 62019 Recanati Italy

## LANDER

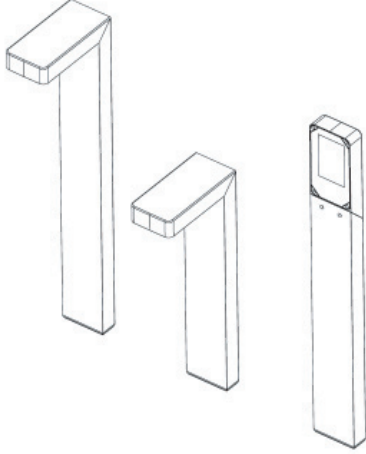

تحذير:

لا يمكن ضمان سلامة هذا الجهاز إلا إذا التزمت بهذه التعليمات. يجب حفظها في مكان آمن.

### ATTENZIONE:

LA SICUREZZA DELL'APPARECCHIO E' GARANTITA SOLO CON L'USO APPROPRIATO DELLE SEGUENTI ISTRUZIONI; PERTANTO E' NECESSARIO CONSERVARLE.

### WARNING:

THE SAFETY OF THIS FIXTURE IS GUARANTEED ONLY IF YOU COMPLY WITH THESE INSTRUCTIONS; REMEMBER TO CONSERVE IN A SAFE PLACE.

### ATENCION:

LA SEGURIDAD DEL APARATO SE GARANTIZA SOLO CUMPLIENDO CUIDADOSAMENTE LAS SIGUIENTES INSTRUCCIONES; POR ELLO, ES NECESARIO CONSERVARLAS.

AR	ملاحظة: أثناء تركيب النظام "LANDER" تم مراعاة قواعد المنظومة المحلية السارية بدقة.
IT	N.B.: DURANTE L'INSTALLAZIONE DEL SISTEMA "LANDER" RISPETTARE SCRUPolosAMENTE LE NORME IMPIANTISTICHE NAZIONALI VIGENTI.
EN	N.B.: WHEN INSTALLING THE "LANDER" SYSTEM, MAKE SURE ALL CURRENT NATIONAL REGULATIONS RELATING TO INSTALLATION ARE OBSERVED.
ES	NOTA: DURANTE LA INSTALACIÓN DEL SISTEMA "LANDER" RESPETAR ESCRUPULOSAMENTE LAS NORMAS NACIONALES DE INSTALACION EN VIGOR.

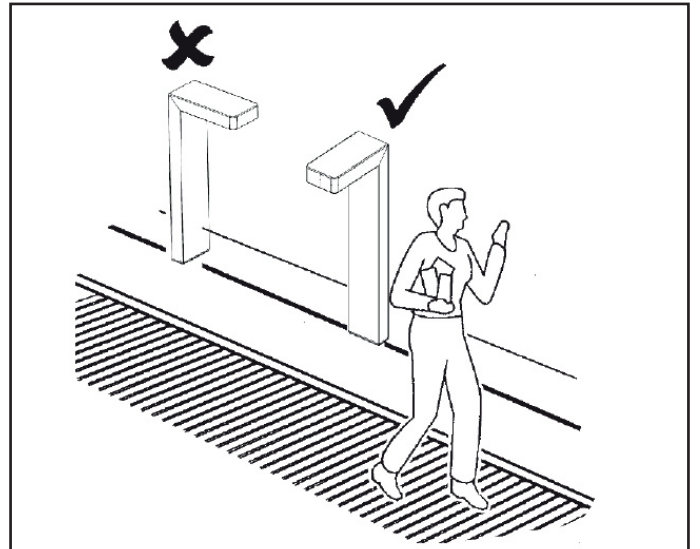
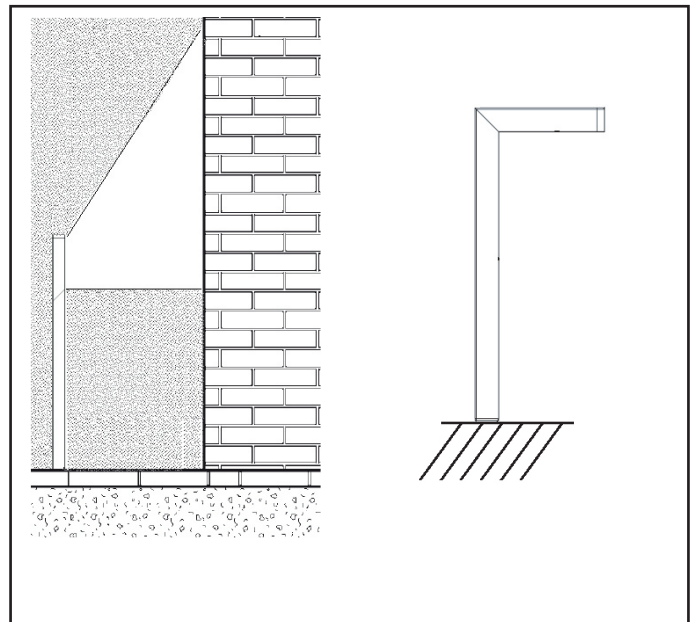
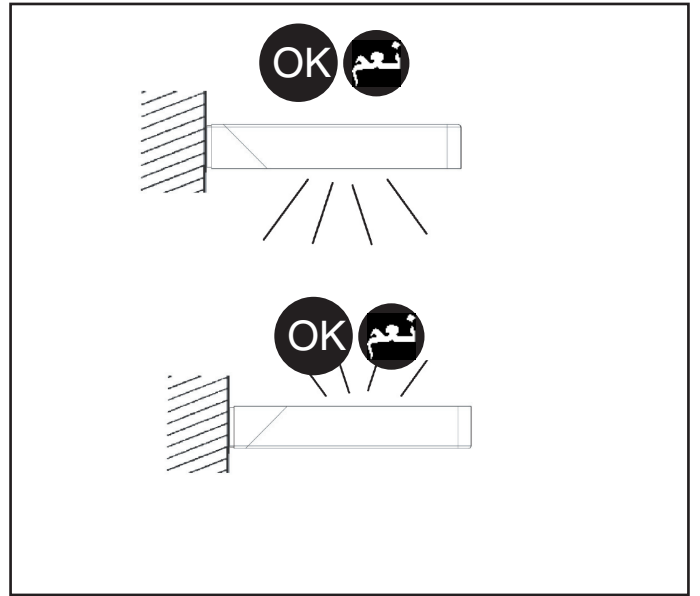
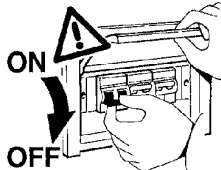

AR

تأكد حينما يتم تركيب الجهاز من عدم وضع القاعدة تحت الأرض أو تمرکزها في المناطق المعرضة لركود الماء.





IT N.B.: Installando l'apparecchio, evitare che la base venga interrata o posizionata in punti soggetti al ristagno dell'acqua.



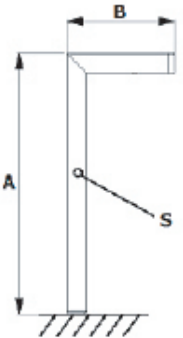

EN N.B.: Whilst installing the appliance, avoid concealing its base or placing it in areas which are susceptible to damp.



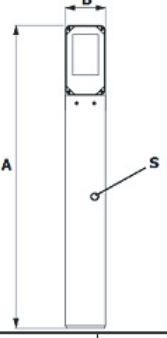

ES NOTA: Al instalar el aparato, evite que la base se entierre o se coloque en puntos donde se pueda estancar el agua.

وزن وقياسات وسطح التركيبة التي تتسفر أقصى حد من الحجم.

PESO, DIMENSIONI E SUPERFICIE DELLA COMPOSIZIONE DI MASSIMO INGOMBRO.  
WEIGHT, DIMENSIONS AND SURFACE OF THE COMPOSITION WITH THE GREATEST SIZE.  
PESO, DIMENSIONES Y SUPERFICIE DE LA COMPOSICIÓN DE MÁXIMO VOLUMEN.

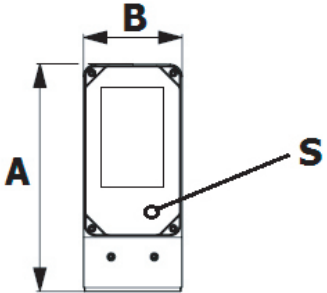
			
ART. الصف	الوزن Peso Weight Peso	الأبعاد Dimensioni Dimensions Dimensiones	السطح Superficie Surface Superficie
ART. الصف			
	8,1	950X271	0,41
	5,8	650X271	0,3

			
ART. الصف	الوزن Peso Weight Peso	الأبعاد Dimensioni Dimensions Dimensiones	السطح Superficie Surface Superficie
ART. الصف			
	6,8	950X126	0,33

			
ART. الصف	الوزن Peso Weight Peso	الأبعاد Dimensioni Dimensions Dimensiones	السطح Superficie Surface Superficie
ART. الصف			
	2,8	290X126	0,1

**AR** ملحوظة هامة: للتوصيل الكهربائي بالشبكة ، استخدم المنتج X188 ، أو أية أجهزة توصيل قادرة على ضمان درجة الحماية IP66 .

**IT N.B.:** Per il collegamento elettrico alla rete, servirsi dell'art. X188 o di altri dispositivi di connessione che garantiscano il grado di protezione IP66.

**EN N.B.:** To make the connection to the mains, use art. X188 or other connection devices which guarantee an IP66 degree of protection.

**ES NOTA:** Para efectuar el enlace a la red eléctrica, utilizar los art. X188 u otros dispositivos de conexión , que garantizan grado de protección IP66.

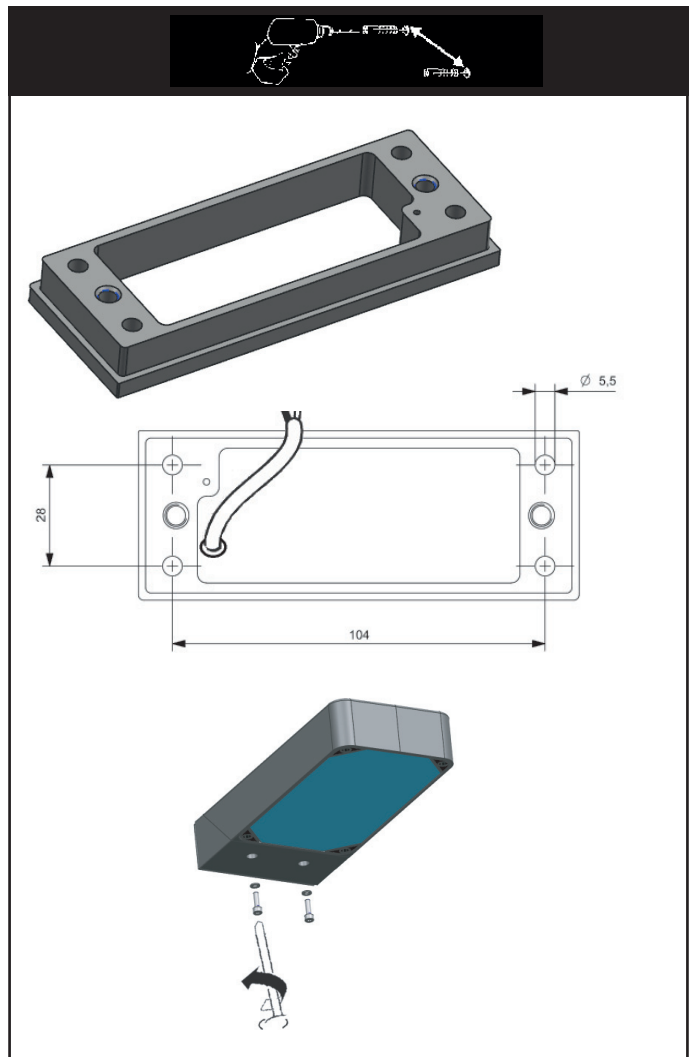

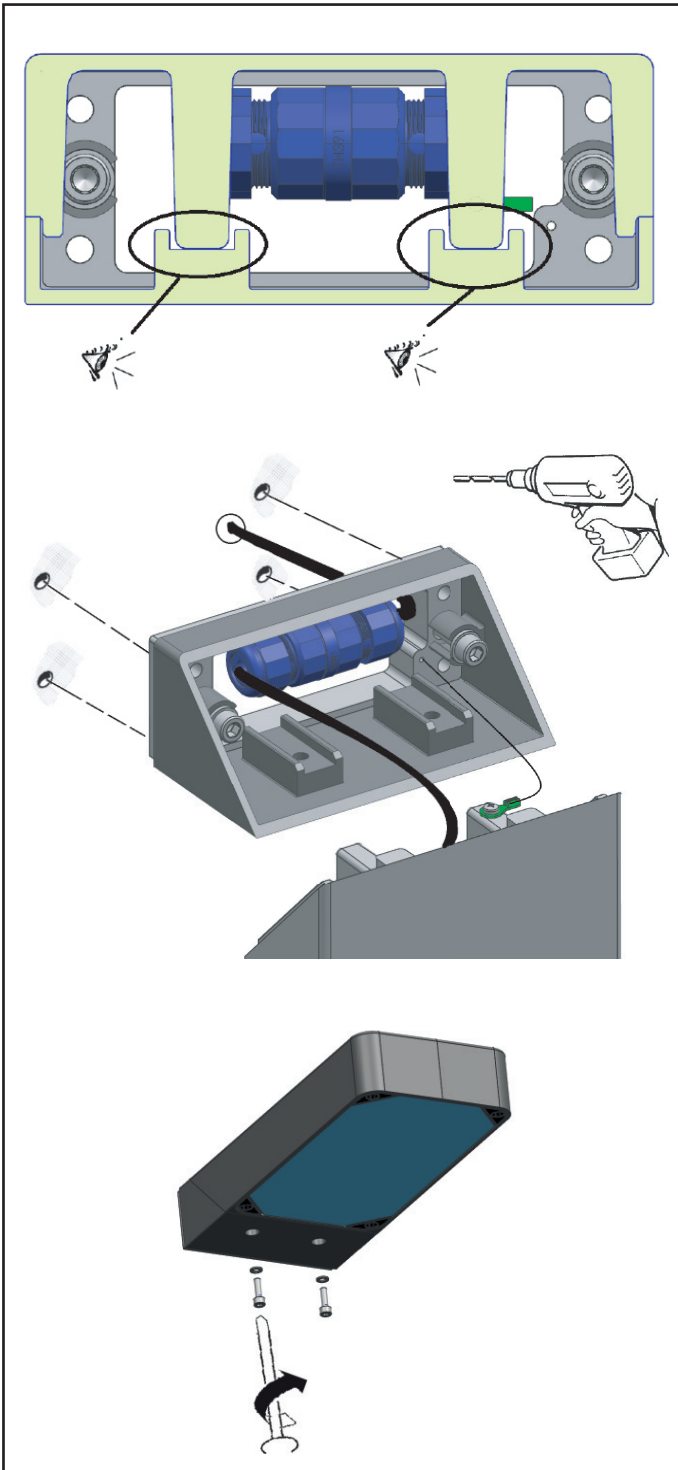

art. ALW0 - ALW1 - ALW2 - ALW3

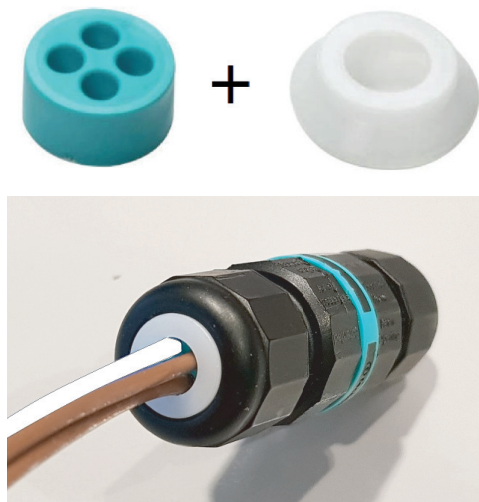

1 - L  
2 - N  
3 - DA  
4 - DA

نیوتن متر  
**1,5 ÷ 2Nm**

نیوتن متر  
**1,5 ÷ 2Nm**

① ↔ ①  
② ↔ ②  
③ ↔ ③  
④ ↔ ④

**MAX 4 mm<sup>2</sup>**

6 mm ملم 6 mm

20 mm 20 mm

D D ( mm )		
2,5 ÷ 3,5 mm		
1,5 ÷ 2 mm		
2,5 ÷ 3 mm		
1,5 ÷ 2 mm		
5,5 ÷ 7 mm		
4,5 ÷ 6,5 mm		
2,5 ÷ 3 mm		
1,5 ÷ 2 mm		
5 ÷ 7 mm		
7 ÷ 9 mm		
9 ÷ 12 mm		

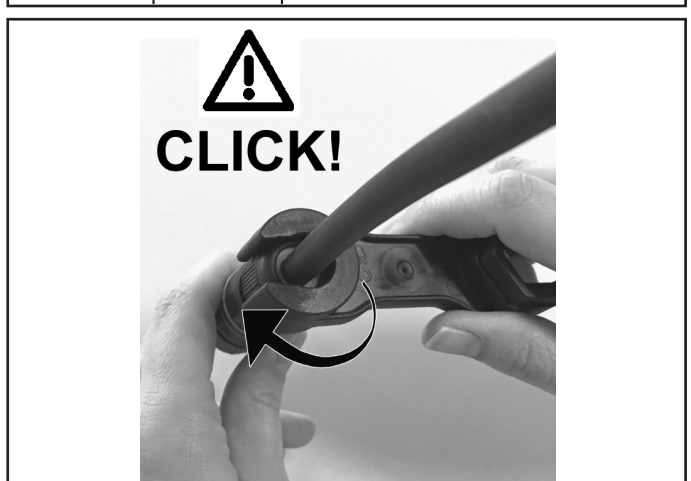



AR عند التثبيت ينصح باستخدام مسامير كبيرة نوع FZA- I- M 6 ÷ 8 أو ما شابهها ومن صنع شركات أخرى.

IT PER IL FISSAGGIO SI CONSIGLIA DI UTILIZZARE TASSELLI PER ANCORAGGI PESANTI TIPO FZA- I- M 6 ÷ 8 FISCHER, O SIMILARI ANCHE DI ALTRI COSTRUTTORI.

EN FOR FIXING USE HEAVY DUTY PLUGS, SUCH AS FZA- I- M 6 ÷ 8 FISCHER OR SIMILAR, INCLUDING FROM OTHER MANUFACTURERS.

ES PARA LA FIJACION SE RECOMIENDA UTILIZAR TACOS PARA ANCLAJES DE GRAN RESISTENCIA, TIPO FZA-I-M 6 ÷ 8 FISCHER, O SIMILARES, INCLUSO DE OTROS FABRICANTES.

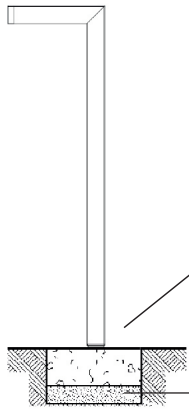
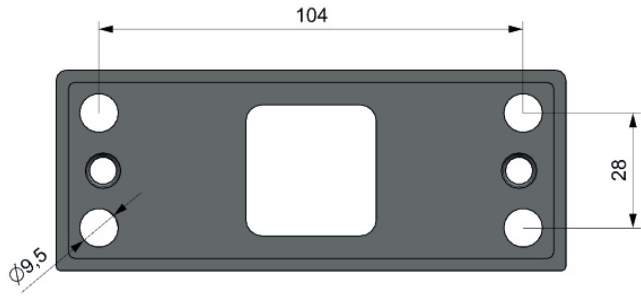
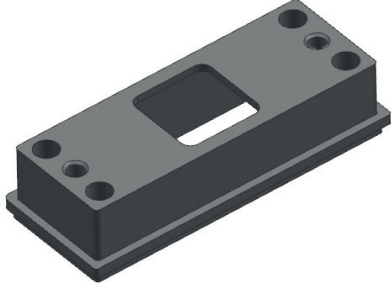

خرسانة  
CALCESTRUZZO  
CONCRETE  
HORMIGÓN

حصى للتصريف  
GHIAIA PER DRENAGGIO  
GRAVEL LAYER FOR DRAINAGE  
GRAVILLA PARA DRENAJ



AR أزل الأشرطة المطاطية قبل استخدام المنتج.

IT Prima di utilizzare il prodotto asportare gli elastici.

EN Remove the elastic bands before using the product.

ES Remover los elásticos antes de utilizar el producto.

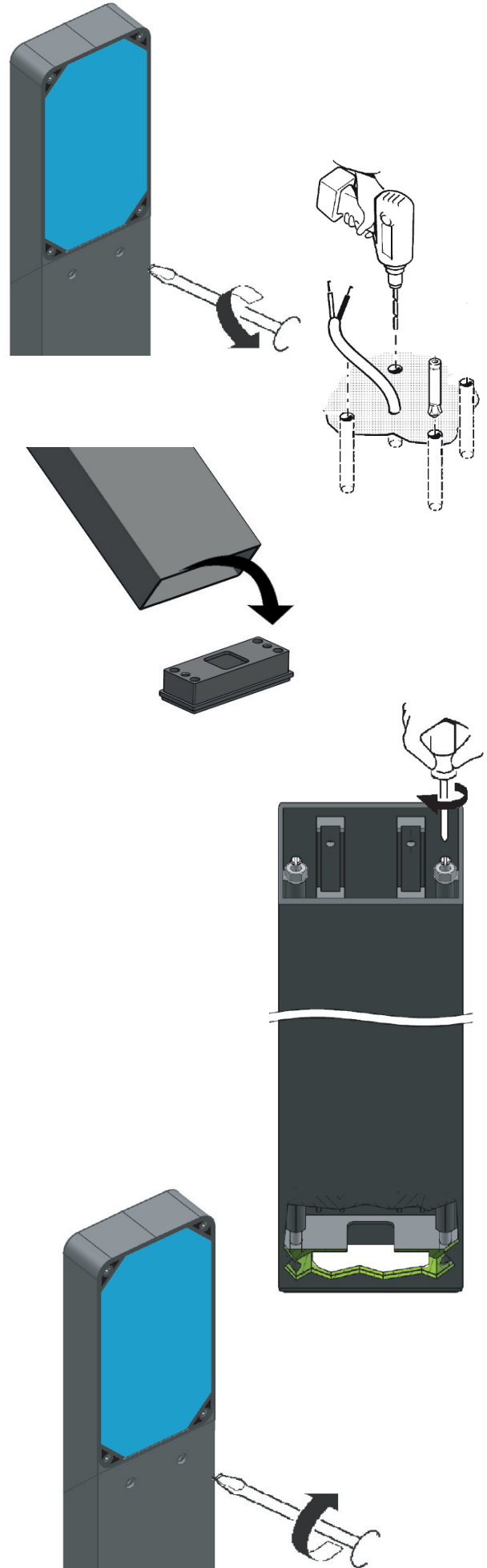

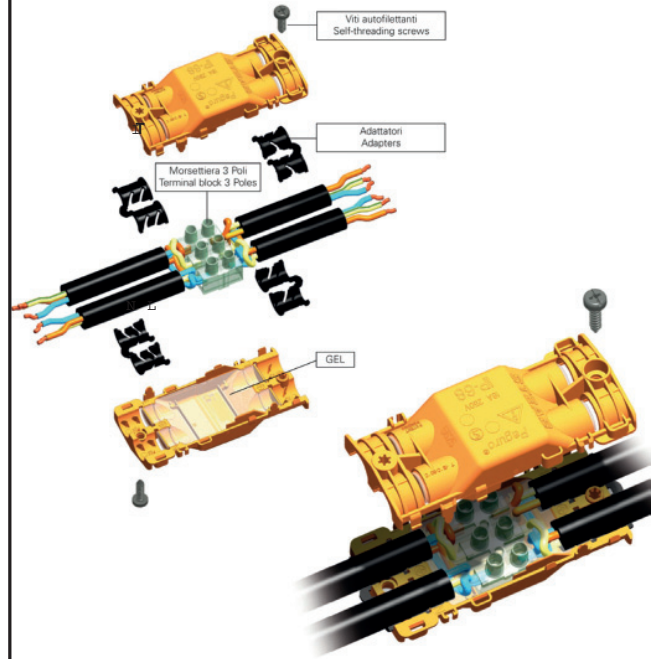
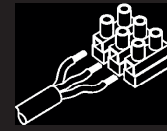
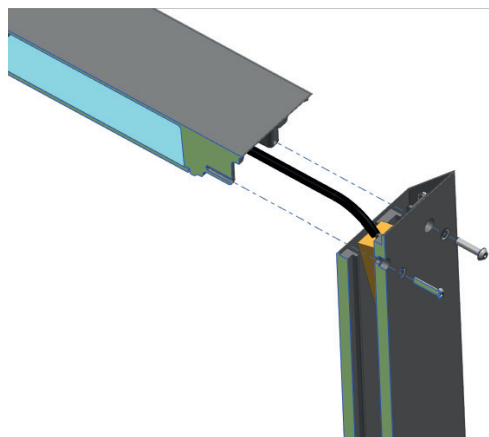
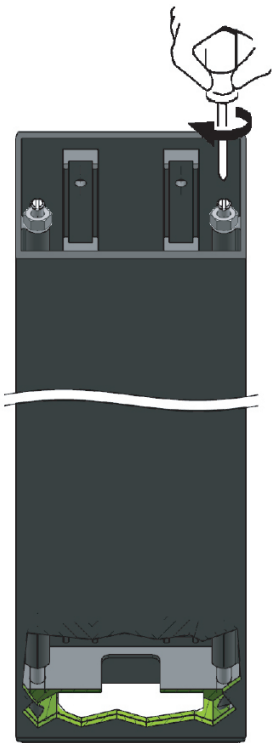
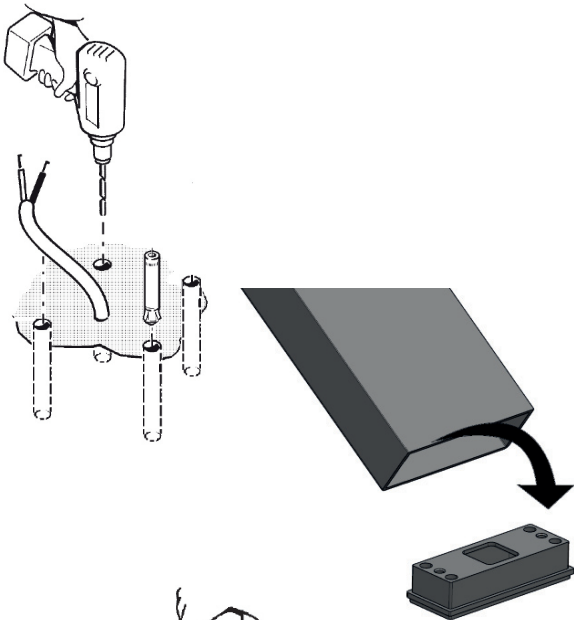

**Posizione cavo**

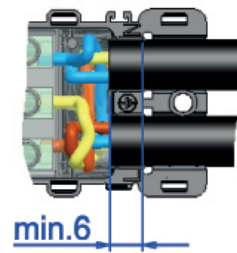

**Schema sguainatura cavo**

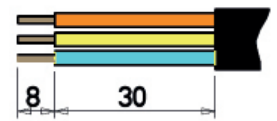

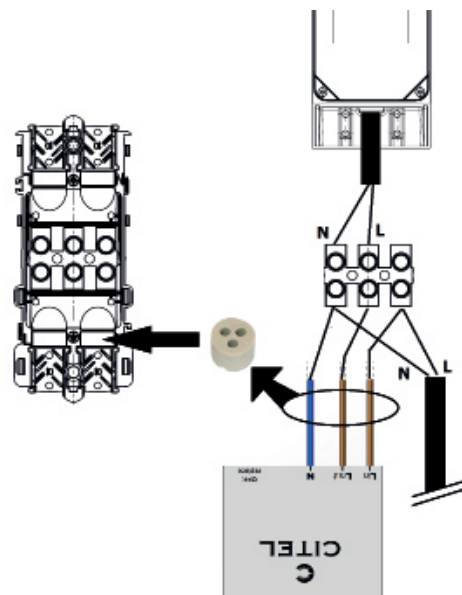

**Morsettiere 3x4 mm<sup>2</sup>**

Per cavi tondi  $\varnothing_{est} D = \text{min } 9.5 - \text{max } 12$   
 $\text{min } 6.5 - \text{max } 9.5$  con adattatori

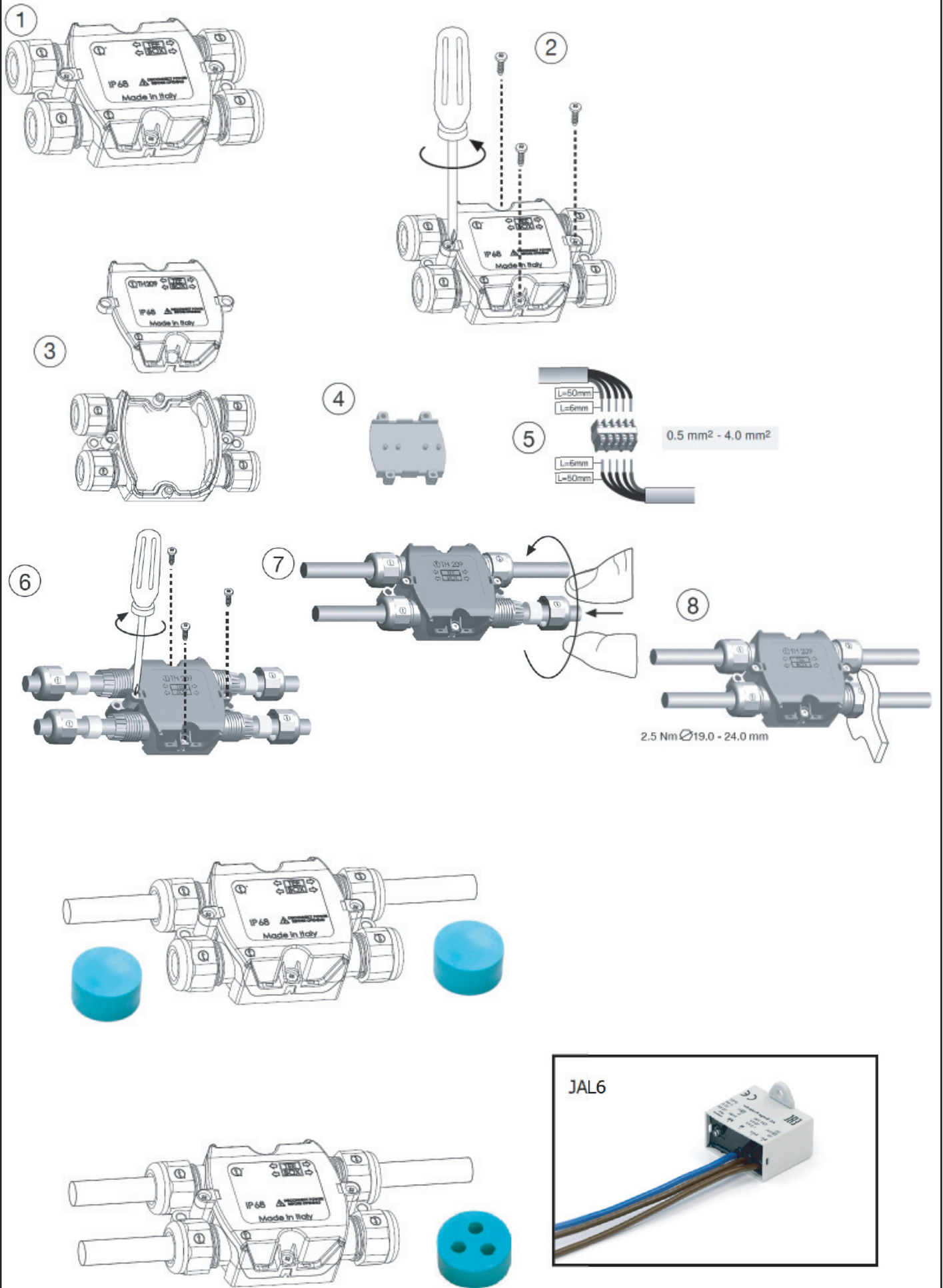

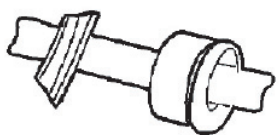
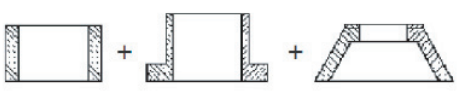
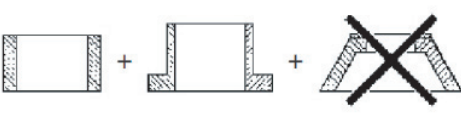

 D ( mm )	
6 ÷ 7 mm	
7 ÷ 9 mm	
9 ÷ 13,5 mm	

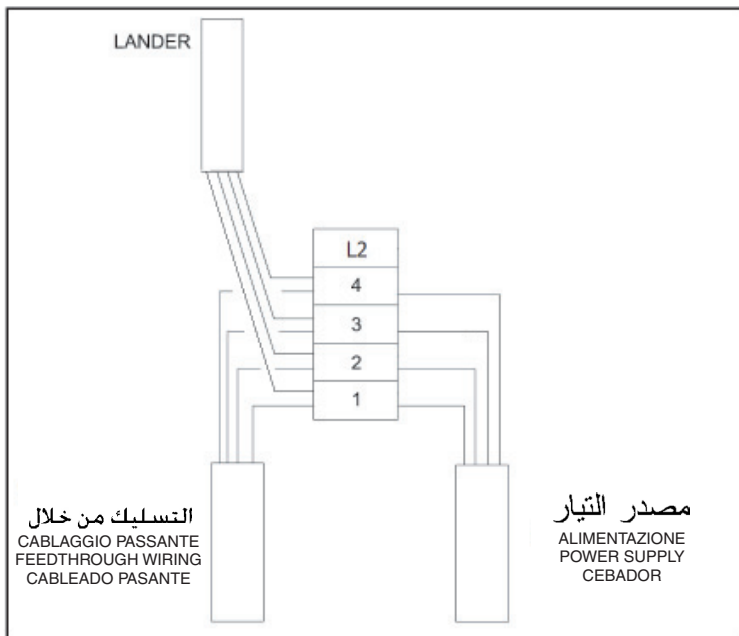

- |  |
|--|
| 1 - L<br>2 - N<br>3 - DA<br>4 - DA<br>L2 - PROTECTED<br>LINE |
|--|

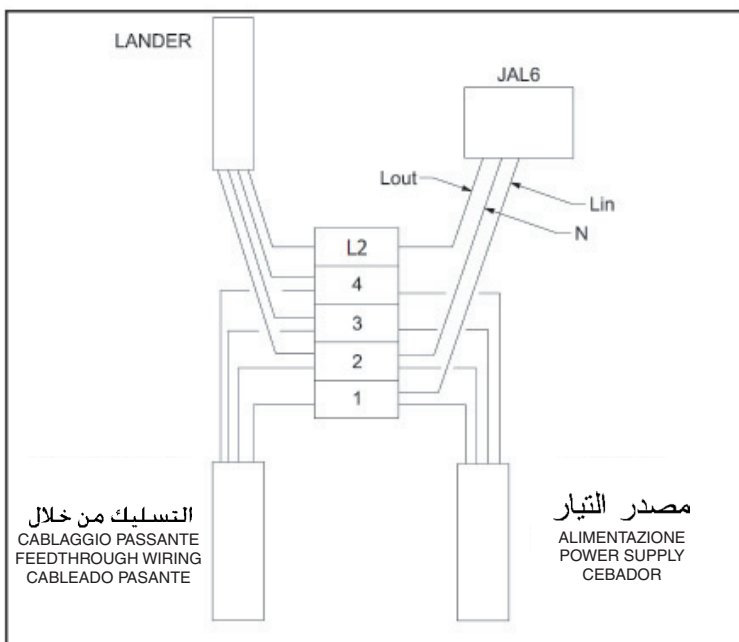

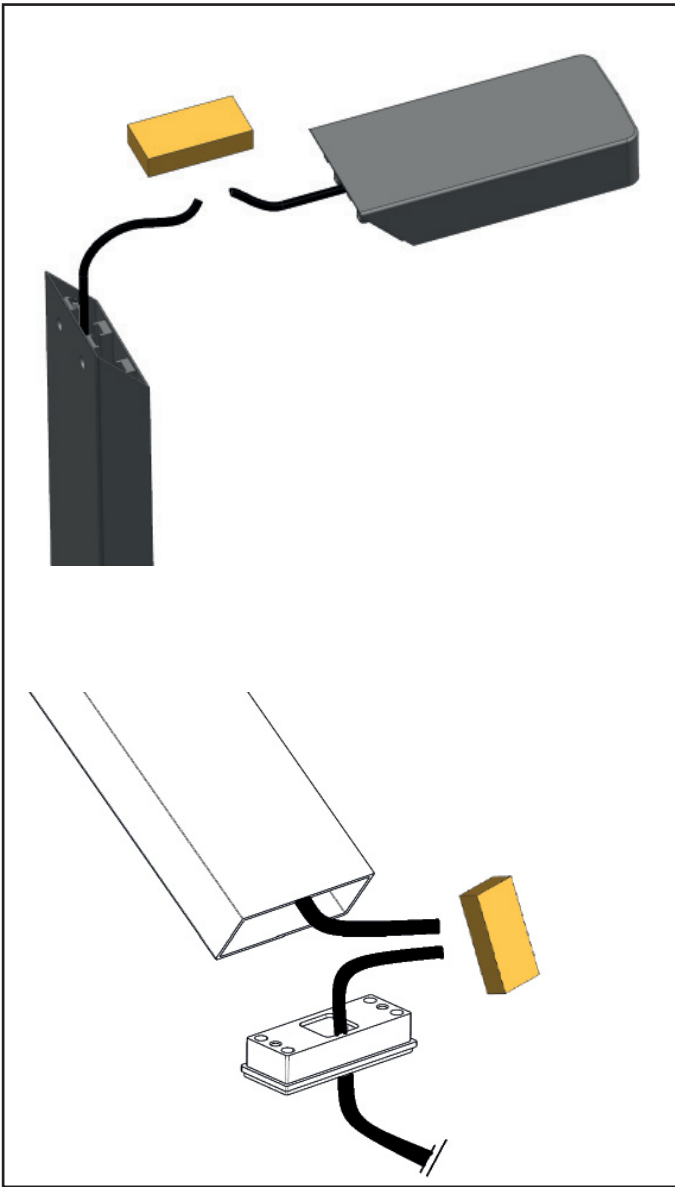

**AR** استعمال كبلات مضاعفة العزل عند التسليك الكهربائي.  
تنبيه: تحقق من عدم تعرية الكبل بشكل زائد.

**IT** Per il cablaggio elettrico utilizzare cavi con doppio isolamento.  
**N.B.:** Accertarsi che la sguainatura del cavo d'alimentazione non sia eccessiva.

**EN** Use cable with double insulation for the electric wiring.  
**N.B.:** Make sure that the power supply cable is not excessively unsheathed.

**ES** Para el cableado eléctrico servirse de cables con doble aislamiento.  
**NOTA:** Asegurarse que el cable de alimentación no resulte excesivamente descubierto.

**AR** في حال تلف الكبل الخارجي المرن، يجب تغييره من قبل المصنع أو من قبل مركز الخدمة المخول أو من قبل أحد أعضاء الطاقم الملائمين والمؤهلين وذلك لتحاكي إلحاق أي خطر.

**IT** In caso di danneggiamento del cavo flessibile esterno, questo deve essere sostituito dal costruttore, o dal suo servizio di assistenza, o da personale qualificato equivalente, al fine di evitare pericoli.

**EN** Should the outer flexible cable be somehow damaged, the latter should be replaced by the manufacturer, or by the corresponding service centre, or by an appropriate and qualified member of staff in order to avoid all risk of danger.

**ES** En caso de daños el cable flexible externo debe substituirse por el fabricante, su servicio de asistencia o personal calificado equivalente para evitar peligros.

**AR** قم بحساب أقصى عدد من المنتجات التي يمكن توصيلها متعاقبة، مع الأخذ في الاعتبار لقدرة التيار الممتصة من الأجهزة، ومقطع الكابل، وطول الكابلات وأقصى تيار للموصلات (A درجة).

**IT** Calcolare il numero massimo dei prodotti collegabili in cascata, tenendo conto dell'assorbimento dei prodotti, della sezione dei cavi, della lunghezza dei cavi e della corrente max dei connettori.

**EN** Calculate the maximum number of products connectable in cascade based on products' consumption, connectors' maximum current, cables' section and length.

**ES** Calcular el número máximo de productos conectables en cascada, teniendo en cuenta la absorción de los productos, la sección de los cables, la longitud de los cables y la corriente máxima de los conectores.

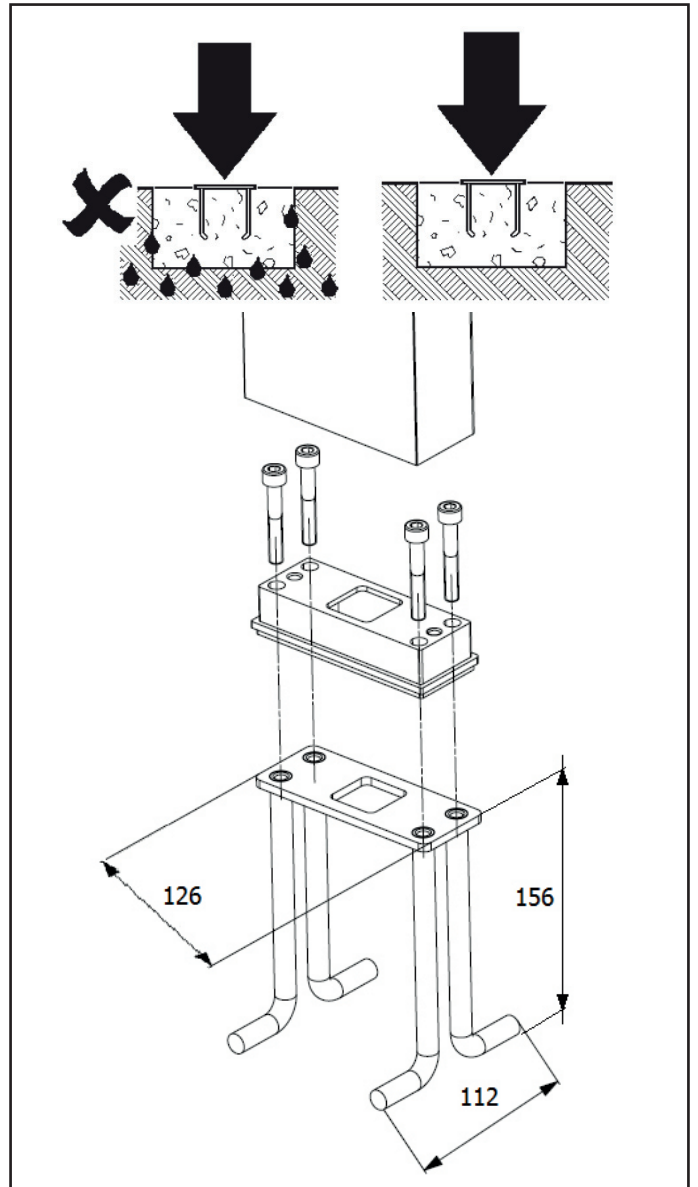

**AR** . iGuzzini LED لاستبدال الضوء اتصل بشركة  
**IT** N.B.: Per la sostituzione del LED contattare l'azienda iGuzzini.  
**EN** N.B.: For information on LED replacement please contact iGuzzini.  
**ES** NOTA: Para sustituir el LED llame a la empresa iGuzzini.

**AR** لا يمكن استعمال المنتج في حالة كسر الزجاج، وبالتالي يجب الاتصال بالمصنع لاستبداله.  
**IT** In caso di rottura del vetro il prodotto non può essere utilizzato, contattare il costruttore per la sua sostituzione.  
**EN** Should the glass break, the product cannot be used and you should contact the manufacturer for its replacement.  
**ES** No utilizar el producto en caso de ruptura del vidrio y contactar el fabricante para la sustitución.

ART. الصنف	عامل القدرة fattore di potenza power factor factor de potencia	التيار الممتص corrente assorbita absorbed current corriente absorbida (A)
AKS9 - AKT0 - AKU1 - AKU2 AKS5 - AKS6 - ALS2 - ALS3 ALS6 - ALS7 - ALW2 - ALW3	0,65	0,09
AKS7 - AKS8 ALS8 - ALS9	0,76	0,106
AKS3 - AKS4 ALW0 - ALW1	0,9	0,127
ALS0 - ALS1 ALS4 - ALS5	0,55	0,08

شحنة DALI / حمل DALI CARICO DALI / DALI LOAD CHARGE DALI CARGA DALI	عناوين DALI INDIRIZZI DALI DALI ADDRESSES DIRECCIONES DALI
1 (2 mA)	1

<p><b>AR</b> المُنْتَج متوافق مع المعيار "دالي" ؛ وذلك مع الإشارة إلى المعايير .EN 62386-101, EN62386-102, EN62386-207</p> <p><b>IT</b> Il prodotto è conforme allo standard DALI, con riferimento alle norme EN 62386-101, EN62386-102, EN62386-207.</p> <p><b>EN</b> The product complies with the DALI standard, with reference to the EN 62386-101, EN 62386-102 and EN 62386-207 standards.</p> <p><b>ES</b> El producto es conforme al estándar DALI, con referencia a las normas EN 62386-101, EN62386-102, EN62386-207.</p>
---