

PALCO LOW VOLTAGE

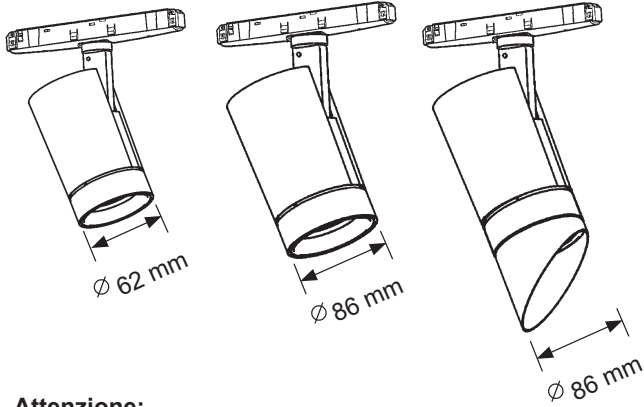

IT **Attenzione:**

La sicurezza dell'apparecchio e' garantita solo con l'uso appropriato delle seguenti istruzioni; pertanto e' necessario conservarle.

EN **Warning:**

The safety of this fixture is guaranteed only if you comply with these instructions; remember to conserve in a safe place.

FR **Attention:**

La sécurité de l'appareil n'est garantie qu'en cas d'utilisation correcte des instructions suivantes; il faut par conséquent les conserver.

DE **Achtung:**

Die sicherheit des gerätes wird nur durch sachgemässe befolgung nachstehender anweisungen gewährleistet; ihre aufbewahrung ist deshalb sehr wichtig.

NL **Opgelet:**

De veiligheid van di atoestel is slechts dan gegarandeerd als indien de volgende instructies strikt worden toegepast: daarom moet men ze ook bewaren.

ES **Atencion:**

La seguridad del aparato se garantiza solo cumpliendo cuidadosamente las siguientes instrucciones; por ello, es necesario conservarlas.

DA **Bemærk:**

Sikkerheden ved brug af armaturet kan kun garanteres, hvis disse anvisninger følges; sørg derfor for at gemme dem.

NO **Advarsel:**

Sikkerheten til dette apparatet garanteres kun hvis du overholder disse instruksjonene; husk å oppbevare dem på et trygt sted.

SV **Observera:**

Utrustningens säkerhet kan endast garanteras om dessa anvisningar respekteras i detalj. Spara därför dessa anvisningar för framtida konsultation.

RU **Внимание:**

Мы гарантируем безопасную эксплуатацию изделия только при соблюдении следующих инструкций; с этой целью необходимо сохранить данную брошюру.

ZH **警告:**

为确保该装置安全, 请遵守操作指示; 并于安全场所放置。

تحذير:

لا يمكن ضمان سلامة هذا الجهاز إلا إذا التزمت بهذه التعليمات. يجب حفظها في مكان آمن.

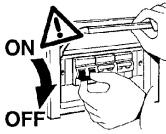

IT N.B.: Durante l'installazione del sistema rispettare scrupolosamente le norme impiantistiche vigenti.

EN N.B.: When installing the system, strictly comply with all regulations on installation in force.

FR N.B.: Lors de l'installation du système veuillez respecter rigoureusement les normes en vigueur en la matière.

DE N.B.: Beachten sie bei der installation des systems gewissenhaft die gültigen bestimmungen bezüglich der anlagentechnik.

NL N.B.: Bij het installeren van het systeem moet u de geldende installatienormen strikt naleven.

ES N.B.: Durante la instalación del sistema respetar e scrupulosamente las normas de instalación vigentes.

DA N.B.: Under installation af systemet skal man nøje overholde de gældende regler for disse anlæg.

NO N.B.: Ved installasjon av systemet skal alle forskrifter om installasjon som gjelder følges strengt.

SV OBS.: Under installationen av systemet ska installationsföreskrifterna respekteras i detalj.

RU примечание: в процессе монтажа системы строго соблюдайте национальные действующие нормативы по электропроводке.

ZH 注意: 在安装系统时请遵守设备的安装规定。

AR ملاحظة: أثناء تركيب النظام يجب التقيد بحرص بالنظم الساندة المتعلقة بالشبكة الكهربائية.



IT IT funzionamento dei prodotti è garantito solo con l'utilizzo di binari ed accessori iGuzzini

EN Correct product operation is only guaranteed if iGuzzini tracks and accessories are used.

FR Le fonctionnement des produits n'est garanti qu'en cas d'utilisation de rails et accessoires iGuzzini

DE Die Funktion der Produkte ist nur mit dem Einsatz von Schienen und Zubehör iGuzzini gewährleistet

NL De werking van de producten wordt alleen gegarandeerd bij het gebruik van iGuzzini rails en accessoires.

ES El funcionamiento de los productos se garantiza solamente si se utilizan railes y accesorios iGuzzini.

DA Produktet er kun garanteret med brug af iGuzzini-skinner og -udstyr.

NO Produktenes korrekte drift garanteres bare ved bruk av spor og tilbehør fra iGuzzini

SV Produkternas funktion garanteras endast vid användning av spår och tillbehör från iGuzzini

RU Функционирование продуктов гарантировано только при использовании бинариев и аксессуаров iGuzzini

ZH 此产品的正常运行只有在使用IGUZZINI的轨道及配件的情况下才可以保证

AR يضمن عمل المنتجات فقط من خلال استعمال سكة ومعدات من نوع iGuzzini

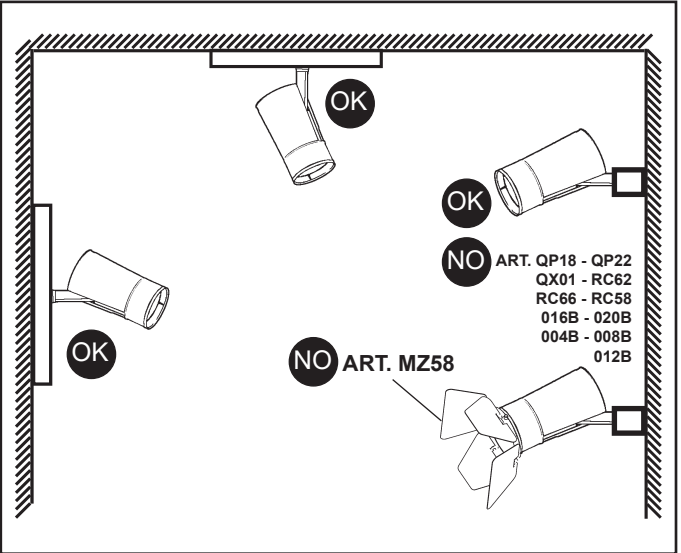

IT Per le posizioni di installazione, attenersi a quelle illustrate, eventualmente contattare la iGuzzini.

EN All installation positions must comply with those illustrated. In the event of any doubt, contact iGuzzini.

FR Pour les positions d'installation, se conformer aux positions illustrées; contacter la société iGuzzini en cas de nécessité.

DE Für die Einbaupositionen die Abbildungen beachten. Eventuell iGuzzini kontaktieren.

NL Houd u voor de installatieposities aan degene die zijn weergegeven. Neem eventueel contact op met iGuzzini.

ES Respetar las posiciones de instalación ilustradas y, en caso de duda, contactar con iGuzzini.

DA For installationspositioner skal man holde sig til de viste, og eventuelt kontakte iGuzzini.

NO For installasjonsplasseringene henviser vi til illustrasjonene, eller ta eventuelt kontakt med iGuzzini.

SV Följ de angivna positionerna för installationen. Kontakta vid behov iGuzzini.

RU При выборе положения для монтажа следует обратиться к проиллюстрированным либо обратиться в компанию iGuzzini.

ZH 安装位置请参考图示, 必要时也可联系iGuzzini.

في ما يتعلق بأوضاع التركيب، التزم بما هو موضح ومحدد، إذا دعت الضرورة اتصل ب iGuzzini

AR

PRODUCT TYPE		ADAPTER	TRACKS V= 48V ± 2V			
				ART. Q618 Q619 Q620 Q621		OK
				ART. Q614 Q615 Q616 Q617		OK
				ART. 6065 6066 6067 6068	12V	OLD NO
				ART. QT52 QT53 QT54 QT55		OK
	PB61			ART. QY65 QY66 QY67 QY68		OK
	PB61			ART. QY69 QY70 QY71 QY72		OK
	PB61			ART. QY73 QY74 QY75 QY76		OK
	PB61			ART. QY77 QY78 QY79 QY80		OK

LOW VOLTAGE TRACK

SUPERRAIL

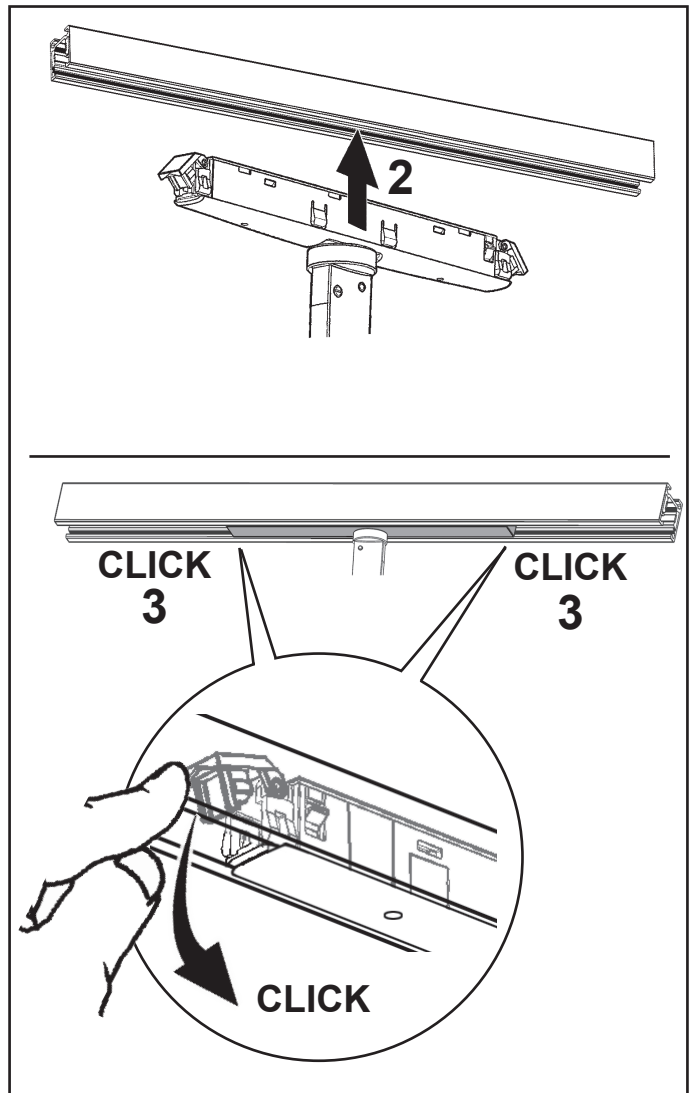
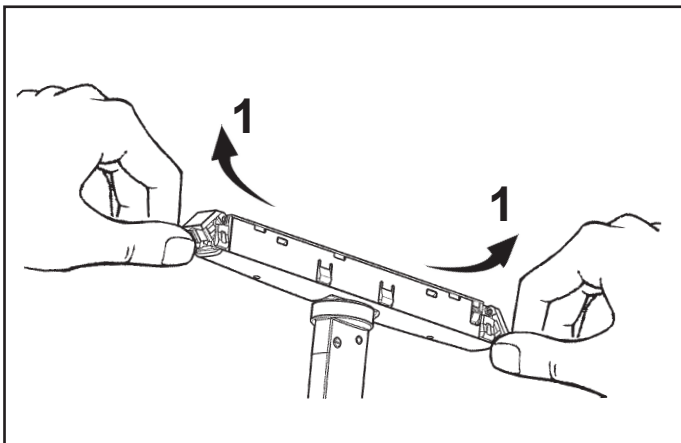

CHANGE POSITION

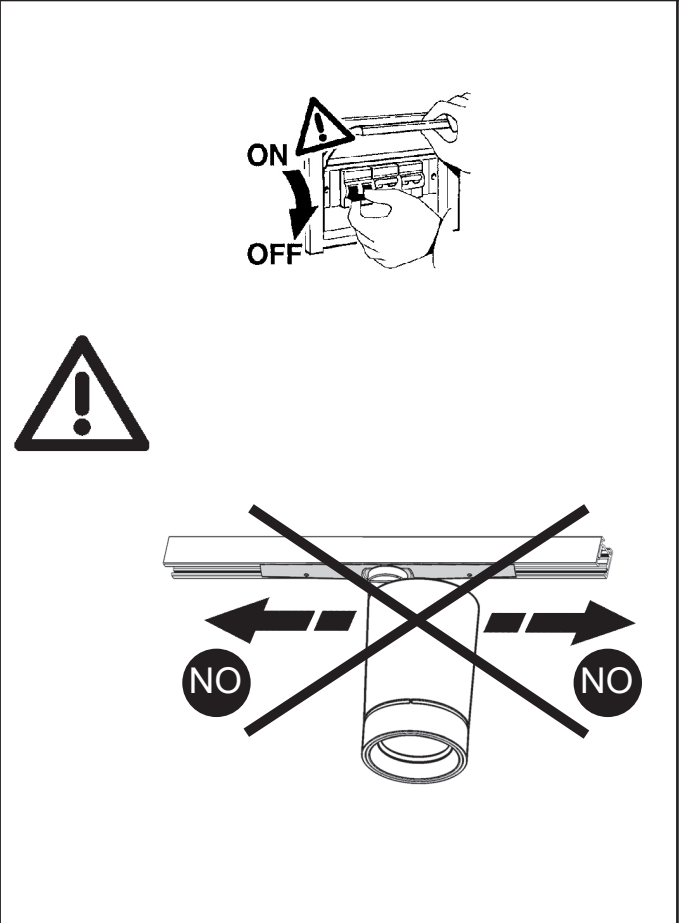

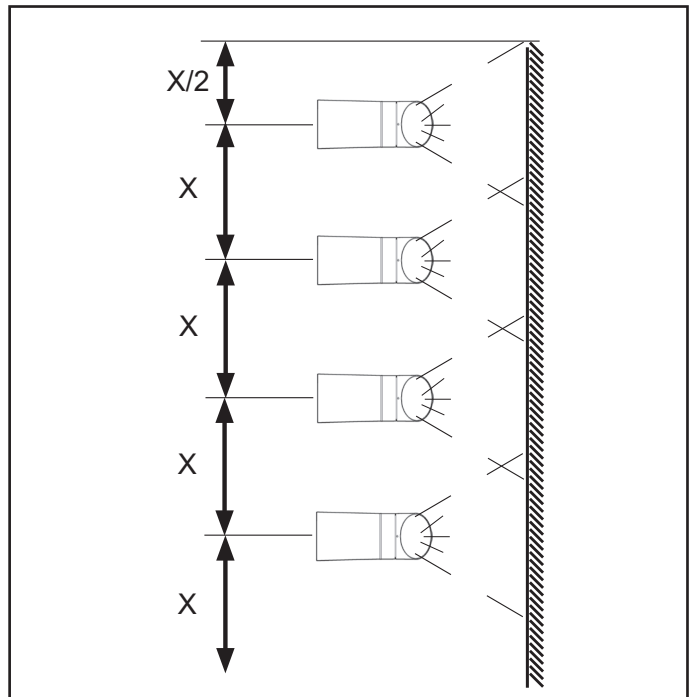
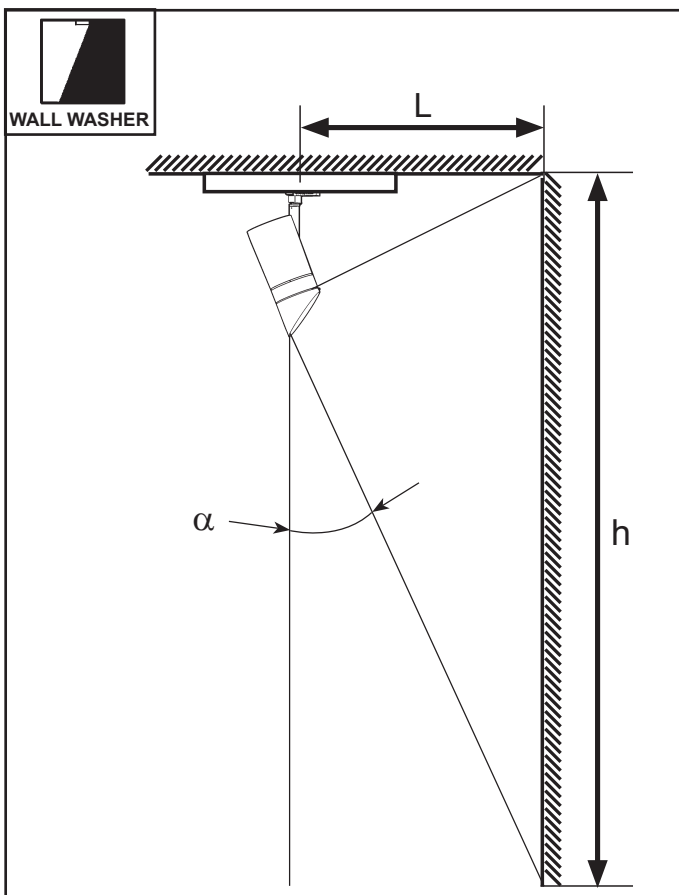
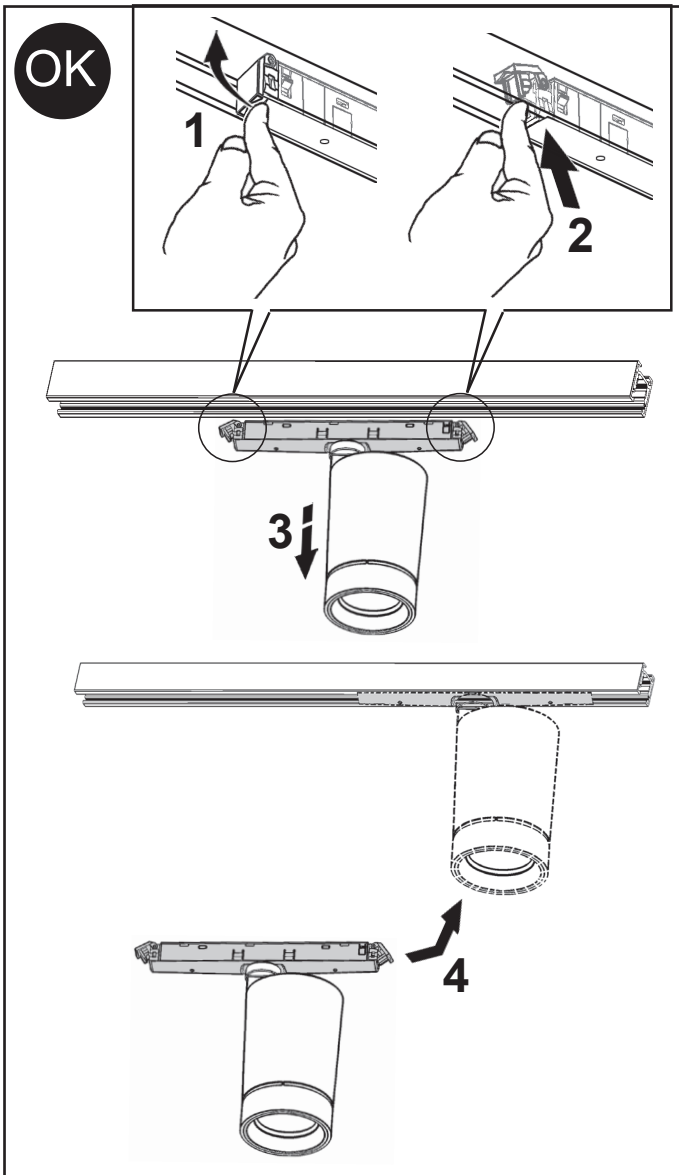

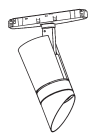
	(X max) m	α	(h) m	(L) m
	0,7	30°	2,7	1

Blocco meccanico del puntamento del vano - mechanical locking of the assembly aiming system - verrouillage mécanique de l'orientation du bloc optique - Mechanische Blockiervorrichtung des Leuchtgehäuses - mechanische blokkering van de richting van de behuizing - bloqueo mecánico del punto de enfoque del cuerpo - mekanisk lås til opsætning af den optiske enheds retning - mekanisk låsing av det optiske rummets retning - mekanisk blockering av det optiska rummets riktning - механическая блокировка ориентации отсека - 装配瞄准系统的机械闭锁 - نظام تثبيت ميكانيكي لتوجيه الصندوق

- IT Se necessario, é possibile bloccare l'orientamento del vano ottico tramite le operazioni "STOP"
- EN If necessary, it is possible to fix the optical assembly by steps "STOP"
- FR Si nécessaire, il est possible de bloquer l'orientation du groupe optique en effectuant les opérations "STOP".
- DE Falls nötig, kann das Optikgehäuse mittels der Operationen "STOP" blockiert werden.
- NL Indien noodzakelijk kunt u de richting van het verlichtingsarmatuur vastzetten door de handelingen "STOP" uit te voeren.
- ES De ser necesario es posible detener la orientación de la Optica, efectuando las operaciones "STOP".
- DA Hvis det er nødvendigt, kan man fastlåse retningen på den optiske enhed ved at følge fremgangsmåden i "STOP"
- NO Ved behov, er det mulig å feste den optiske enheten ved trinn "STOP".
- SV Om det är nödvändigt går det att blockera det optiska rummets riktning med momenten "STOP"
- RU При необходимости можно заблокировать направление оптического проема с помощью операций "STOP".
- ZH 需要时, 可以按照 "STOP" 号操作来固定光学组装位置。
- AR في حالة الضرورة, يمكن غلق توجيه التجويف البصري من خلال عملية الإيقاف "STOP"

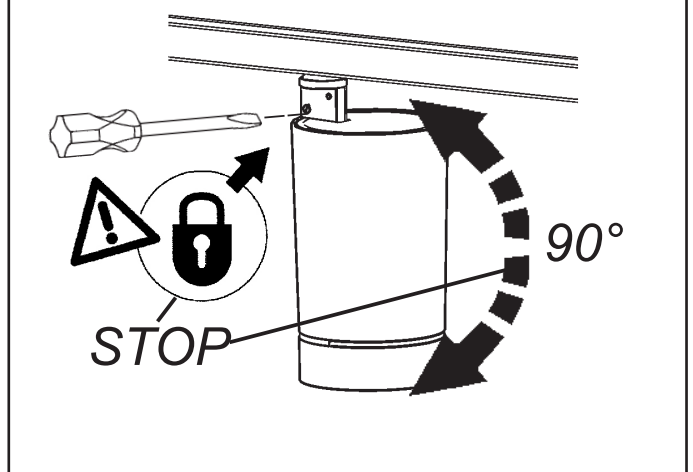

+ Art.

ART.	Soft lens art.	art.	art.	art. *	art.
QP07 - QP08 - QP10 - QP11 QP13 - QP14 - QW99 - QX00 RC44 - RC45 - RC47 - RC48 RC50 - RC51 - RC53 - RC54 990A - 993A - 996A - 991A 994A - 997A	MY23	MY24	MZ81	MZ55	MZ56
QP06 - QP09 - QP12 - QW98 RC43 - RC46 - RC49 - RC52 989A - 992A - 995A - 998A 001B	/				
QP15 - QP16 - QP17 - QP19 QP20 - QP21 - QP23 - QP24 QP25 - QX02 - QX03 - QX04 RC55 - RC56 - RC57 - RC59 RC60 - RC61 - RC63 - RC64 RC65 - RC67 - RC68 - RC69 005B - 009B - 013B - 006B 010B - 014B - 007B - 011B 015B - 017B - 018B - 019B 021B - 022B - 023B	MY46	MXV1	MY38	MZ57	MZ58
QP18 - QP22 - QX01 - RC58 RC62 - RC66 - 004B - 008B 012B - 016B - 020B	/				

IT	Si consiglia l'utilizzo di questo accessorio solo in abbinamento con l'accessorio SOFT LENS.
EN	We recommend using this accessory only in combination with the SOFT LENS accessory
FR	Il est conseillé de n'utiliser cet accessoire qu'en combinaison avec l'accessoire SOFT LENS.
DE	Wir empfehlen, dieses Zubehör nur in Verbindung mit dem Zubehör SOFT LENS zu verwenden
NL	We raden u aan dit accessoire alleen te gebruiken in combinatie met het accessoire SOFT LENS.
ES	Se recomienda el uso de este accesorio sólo en combinación con el accesorio SOFT LENS.
DA	Det tilrådes at bruge denne accessorie udelukkende sammen med udstyre SOFT LENS.
NO	Det anbefales å bruke dette tilbehøret kun sammen med SOFT LENS-tilbehøret
SV	Det rekommenderas att endast använda detta tillbehör tillsammans med tillbehöret SOFT LENS.
RU	ВНИМАНИЕ: ЧТОБЫ РАЗБЛОКИРОВАТЬ ПРОДУКТ, МАКС. 2 ОБОРОТА КЛЮЧА
ZH	我们建议此配件仅与 SOFT LENS 配件配套使用
AR	ننصح باستخدام هذا الملحق فقط بالاقتران مع الملحق SOFT LENS

ART.	super spot	spot	medium	flood	wide
QP15 - QP16 QP17 - QP19 QP20 - QP21 QP23 - QP24 QP25 - QX02 QX03 - QX04 RC55 - RC56 RC57 - RC59 RC60 - RC61 RC63 - RC64 RC65 - RC67 RC68 - RC69 005B - 006B 007B - 009B 010B - 011B 013B - 014B 015B - 016B 017B - 018B 019B - 020B 021B - 022B 023B	/	/	MZ59	MZ60	MZ61

ART.	Super Spot	Medium	Flood	Wide Flood
QP18 - QP22 QX01 - RC58 RC62 - RC66 004B - 008B 012B - 016B 020B	/	MY47	MY48	MY49

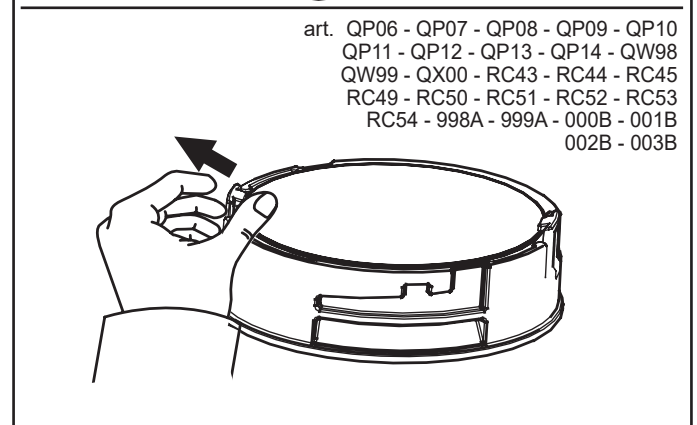
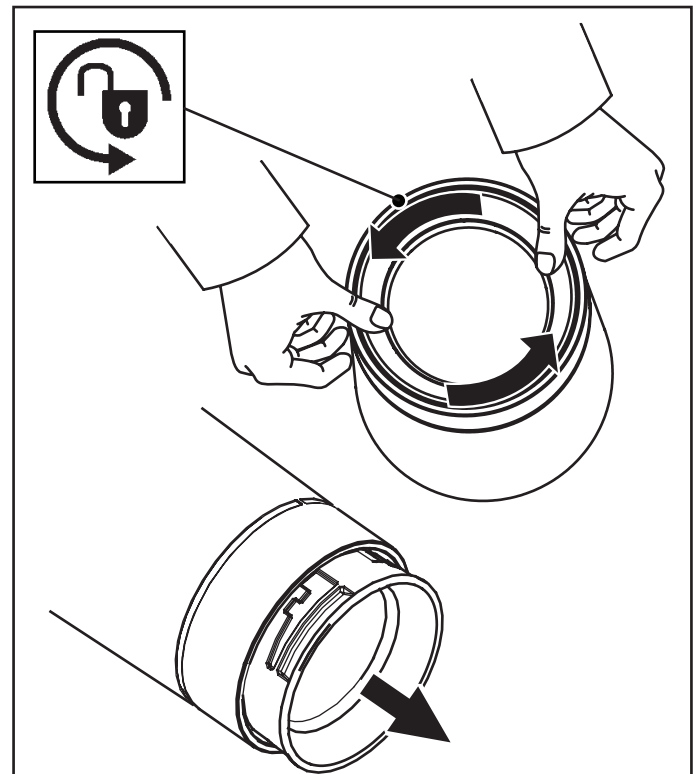
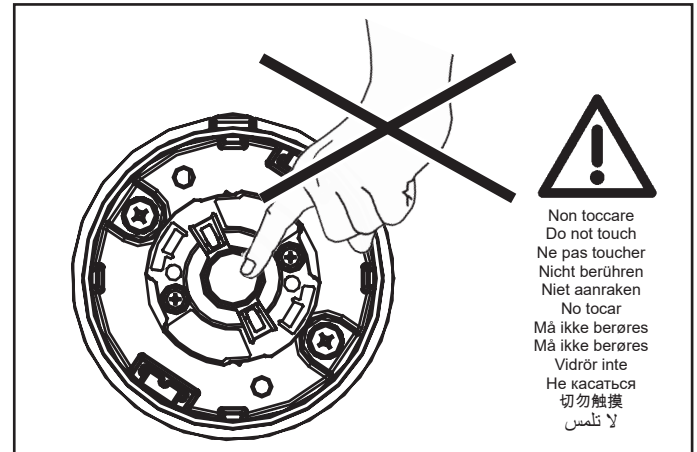

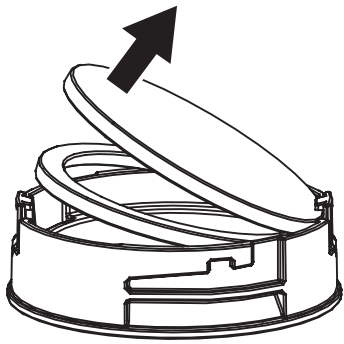

art. MY23

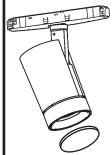
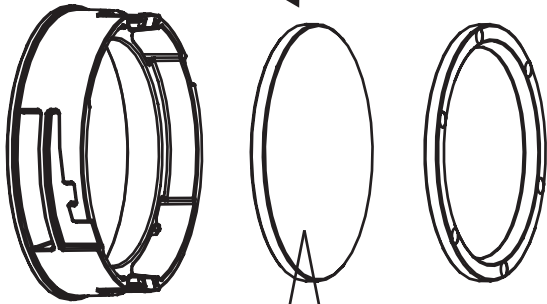

NO

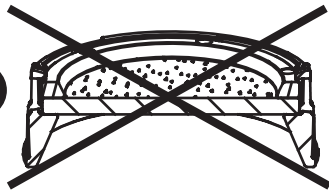

OK

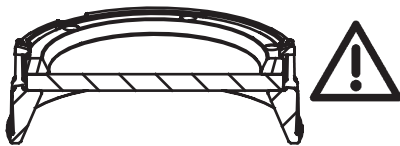

art. MY24

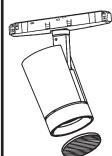
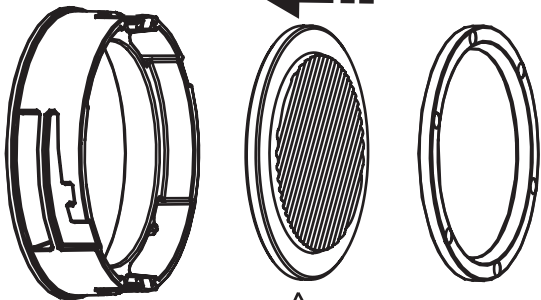

NO

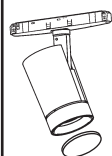
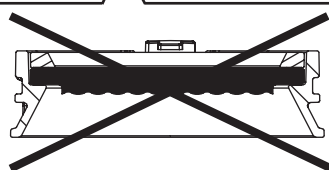

OK



art. MZ81

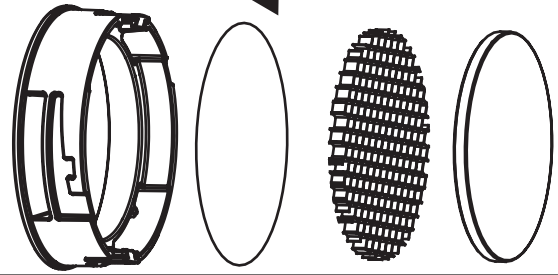

art. QP15 - QP16 - QP17 - QP18 - QP19 - QP20 - QP21 - QP22
 QP23 - QP24 - QP25 - QX01 - QX02 - QX03 - QX04 - RC55
 RC56 - RC57 - RC58 - RC59 - RC60 - RC61 - RC62 - RC63
 RC64 - RC65 - RC66 - RC67 - RC68 - RC69 - 004B - 005B
 006B - 007B - 008B - 009B - 010B - 011B - 012B - 013B - 014B
 015B - 016B - 017B - 018B - 019B - 020B - 021B - 022B - 023B

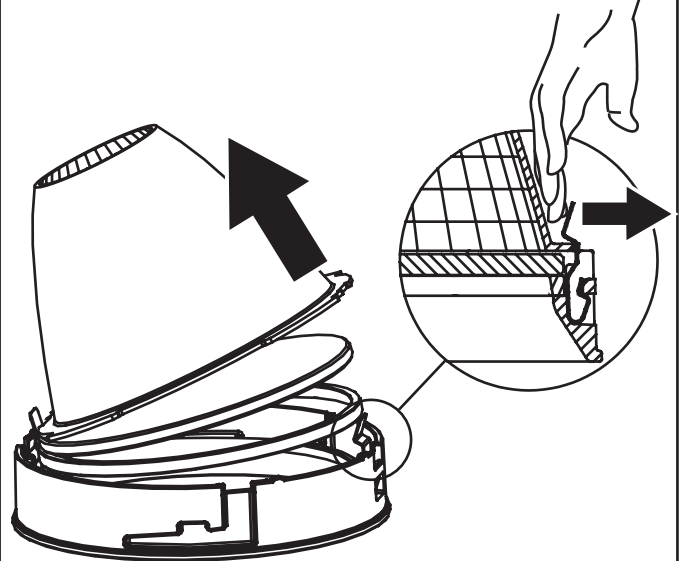

art. MY46

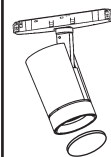
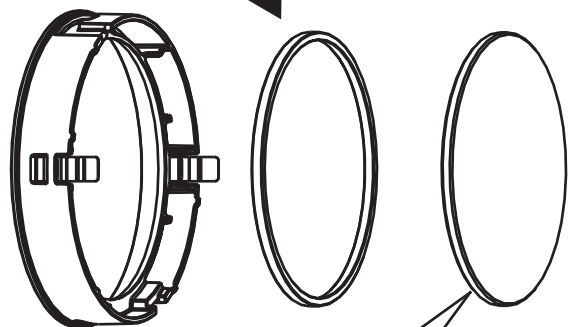

NO

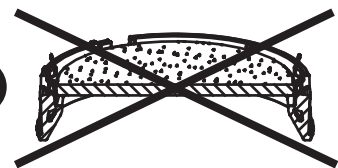

OK

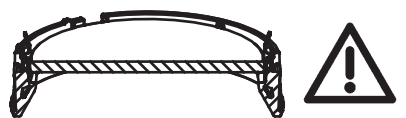

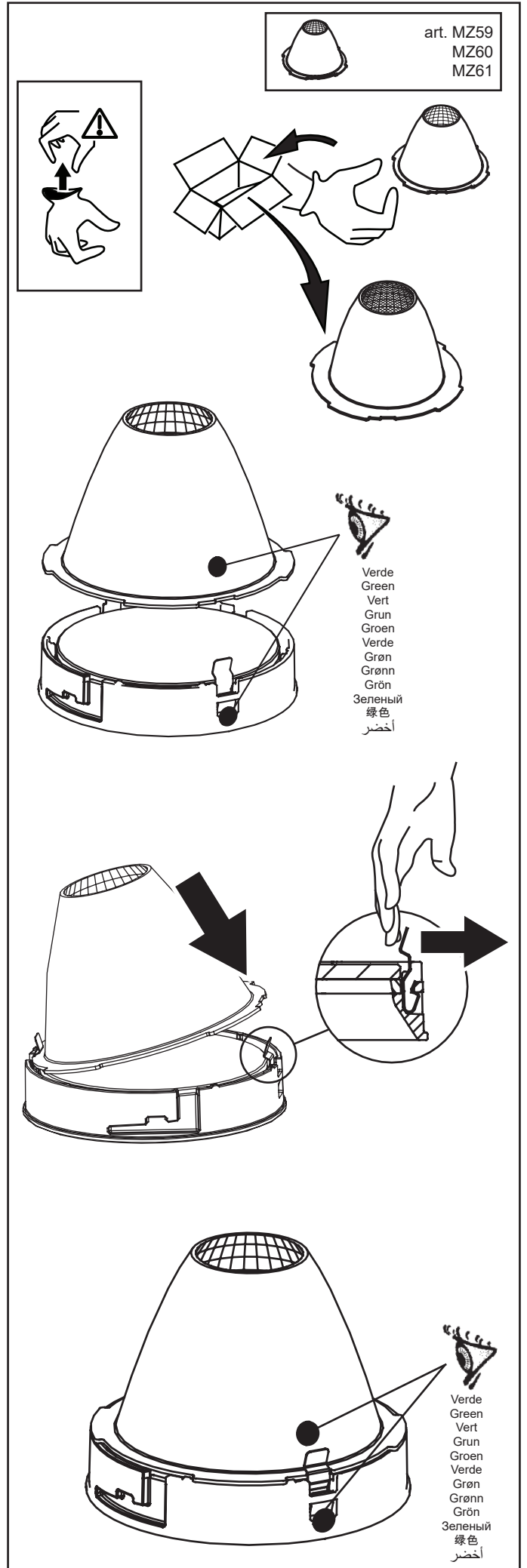
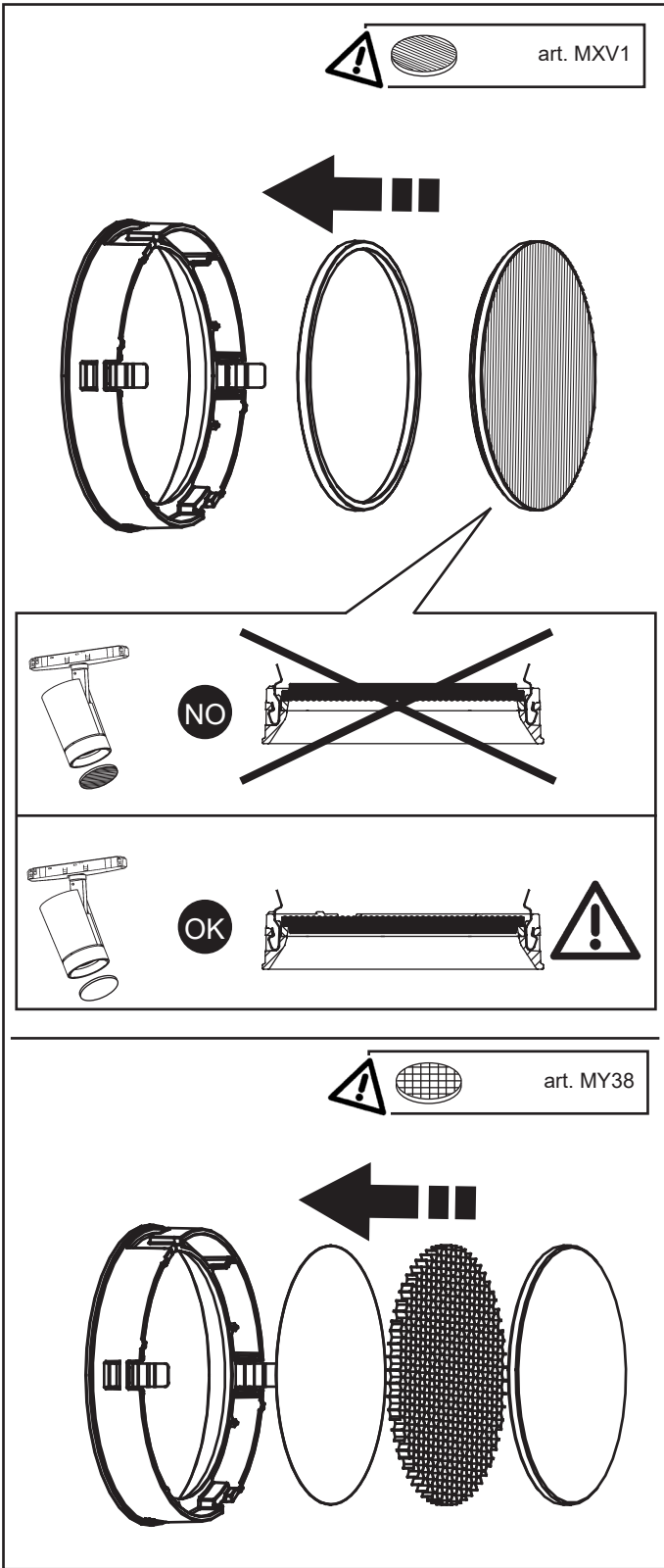

art. QP18 - QP22 - QX01 - RC58 - RC62 - RC66
004B - 008B - 012B - 016B - 020B

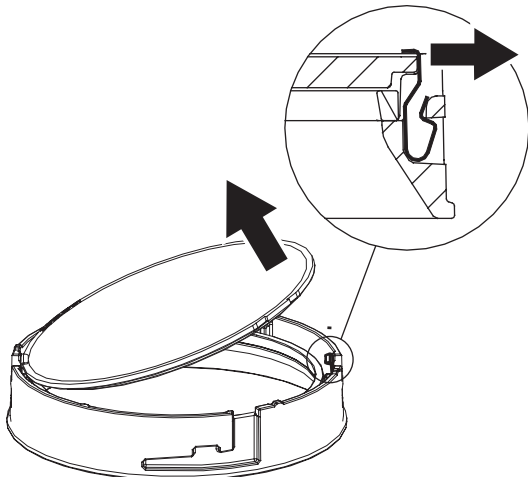

  art. MXV1

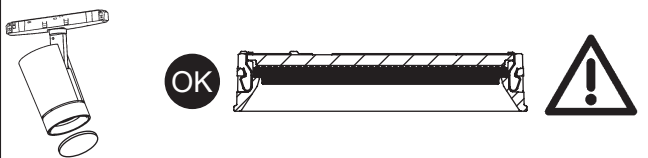
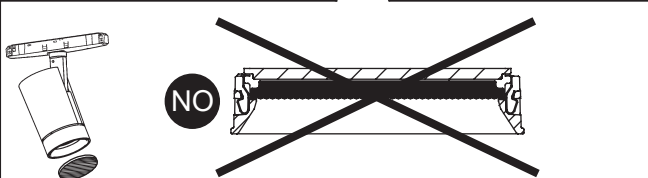
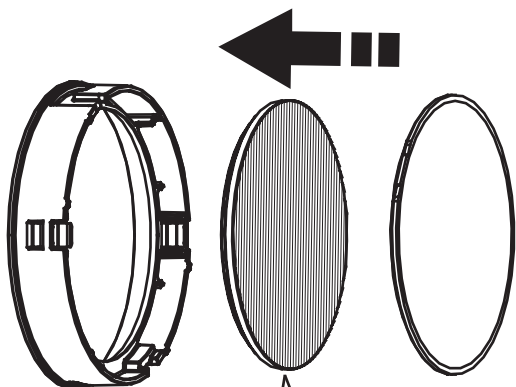



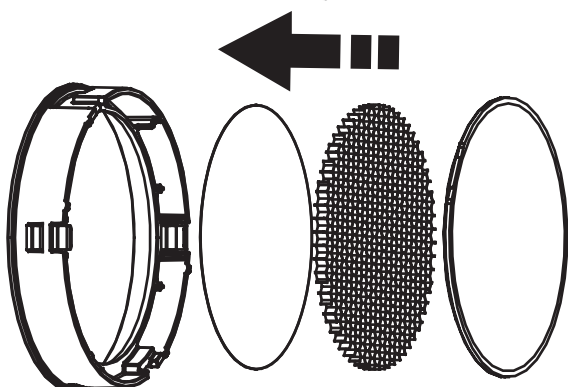



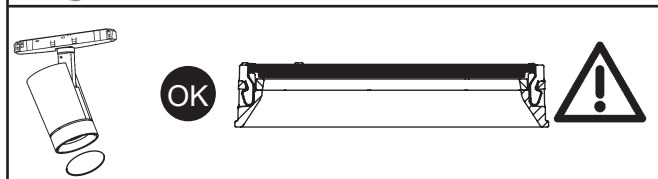
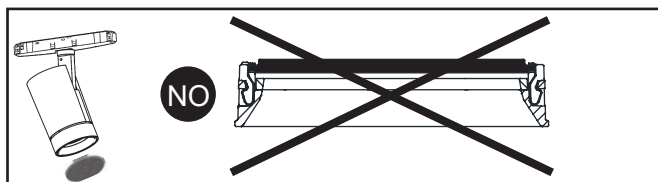
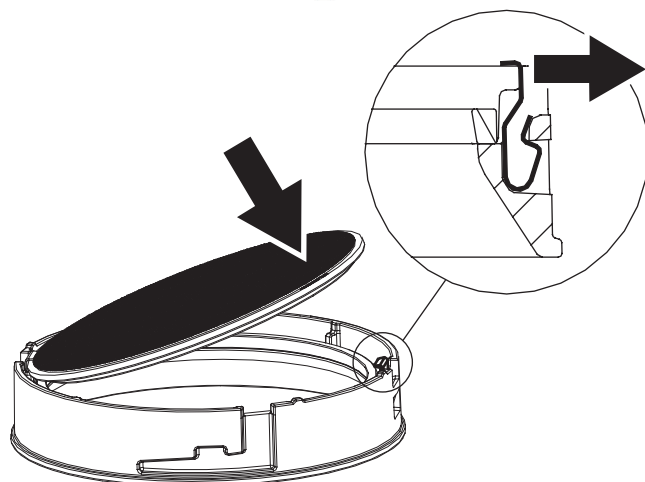
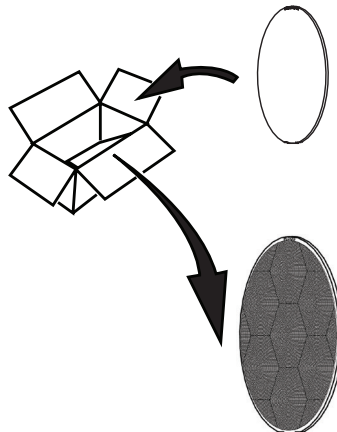











  art. MZ81



art. MY47
MY48
MY49



 art. MZ81
MY38

	 + 	
	 + 	
	 + 	
	 + 	
		

	+			NO	art. MY24 MXV1
	+			NO	
	+			OK	
				OK	

	+			NO	art. MY23 MY46
	+			NO	
				OK	

	+			NO	art. MY47 MY48 MY49
				OK	

ART.		
QP06 - QP07 - QP08 - QP09 - QP10 - QP11 QP12 - QP13 - QP14 - QP15 - QP16 - QP17 QP18 - QP19 - QP20 - QP21 - QP22 - QP23 QP24 - QP25 - QW98 - QW99 - QX00 - QX01 QX02 - QX03 - QX04 - RC43 - RC44 - RC45 RC46 - RC47 - RC48 - RC49 - RC50 - RC51 RC52 - RC53 - RC54 - RC55 - RC56 - RC57 RC58 - RC59 - RC60 - RC61 - RC62 - RC63 RC64 - RC65 - RC66 - RC67 - RC68 - RC69 000B - 001B - 002B - 003B - 004B - 005B 006B - 007B - 008B - 009B - 010B - 011B 012B - 013B - 014B - 015B - 016B - 017B 018B - 019B - 020B - 021B - 022B - 023B 989A - 990A - 991A - 992A - 993A - 994A 995A - 996A - 997A - 998A - 999A	n°2 MAX	n°1 MAX

art. MZ55
MZ57

art. MZ56
MZ58

art. QP06 - QP07 - QP08
 QP09 - QP10 - QP11
 QP12 - QP13 - QP14
 QW98 - QW99 - QX00
 RC43 - RC44 - RC45
 RC46 - RC47 - RC48
 RC49 - RC50 - RC51
 RC52 - RC53 - RC54
 000B - 001B - 002B
 003B - 989A - 990A
 991A - 992A - 993A
 994A - 995A - 996A
 997A - 998A - 999A

art. QP15 - QP16 - QP17 - QP19 - QP20 - QP21 - QP23 - QP24
 QP25 - QX02 - QX03 - QX04 - RC55 - RC56 - RC57 - RC59
 RC60 - RC61 - RC63 - RC64 - RC65 - RC67 - RC68 - RC69
 005B - 006B - 007B - 009B - 010B - 011B - 013B - 014B - 015B
 017B - 018B - 019B - 021B - 022B - 023B

art. QP18 - QP22 - QX01 - RC58 - RC62 - RC66
004B - 008B - 012B - 016B - 020B

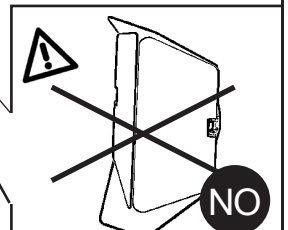
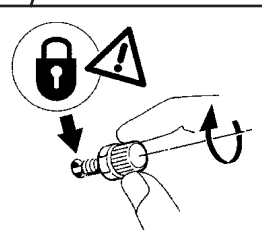
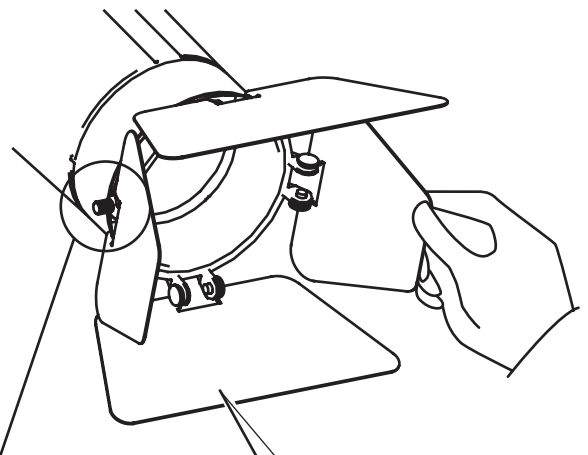
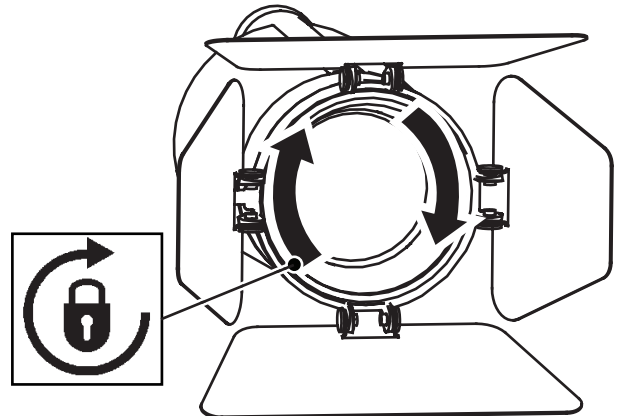
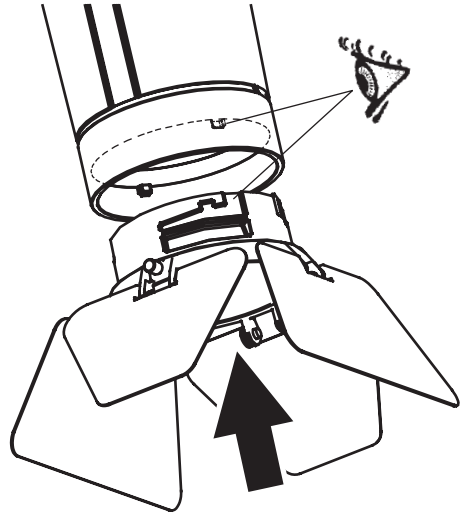
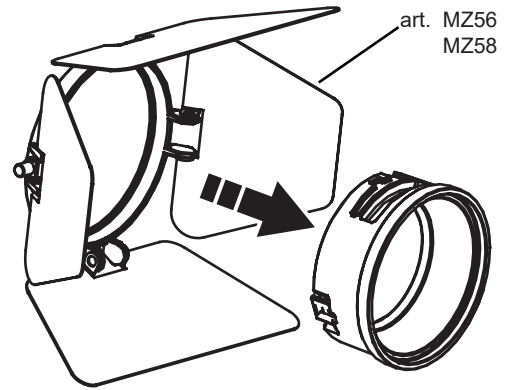
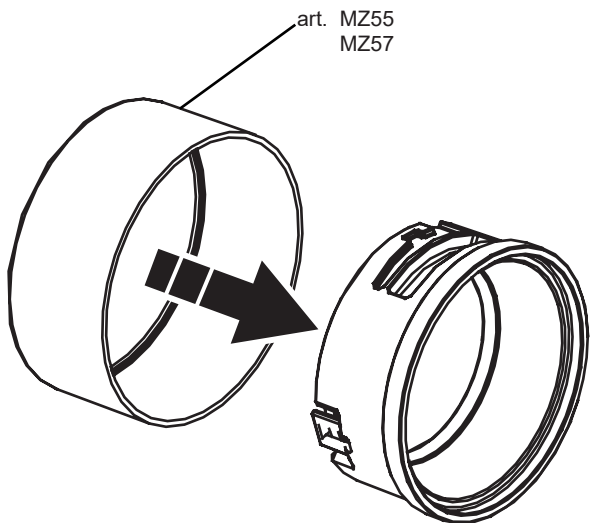
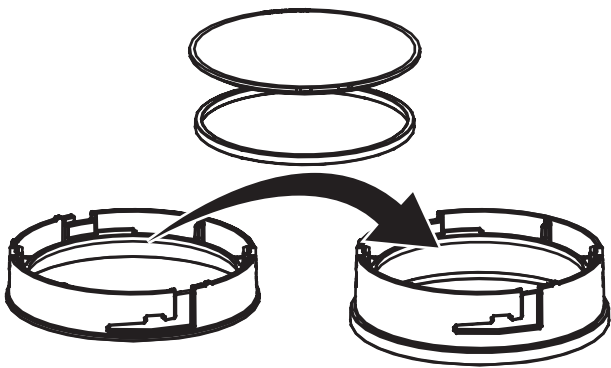
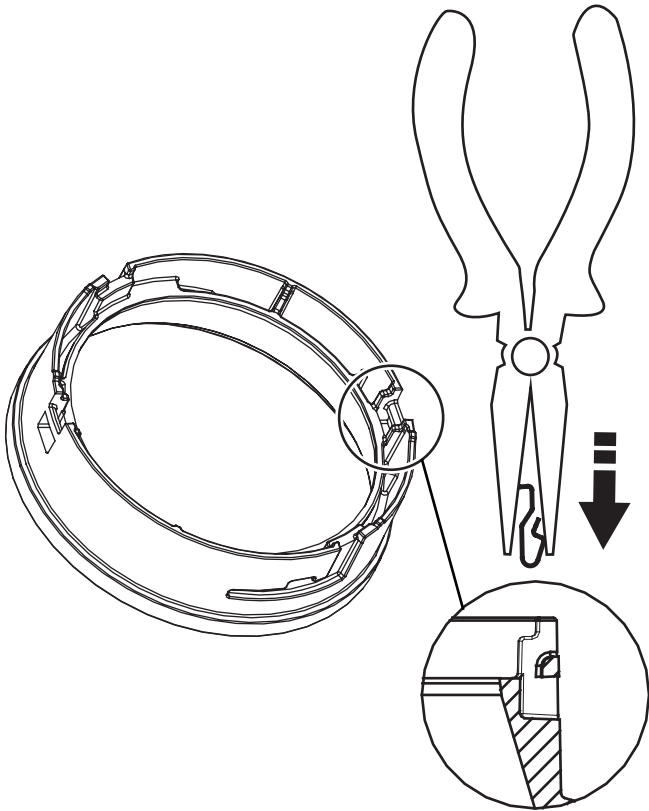

Carico dali / dali load Charge dali (Courant maxi admissible) Dali-last Dali vermogen Carga dali Dali strømstyrke Belastning for "dali" Dali-belastning Макс. Ток системы dali с регуляцией интенсивности света DALI 智能调光系统允许的最大电流量 DALI شحنة / DALI شحنة	Indirizzi dali Dali addresses Adresses dali Dali-adressen Dali adressen Direcciones dali Dali addresser Adresser til "dali" Dali-adresser Логические адреса системы dali DALI智能调光系统计算机指定控制参数 DALI عناوين
1 (2 mA)	1

IT N.B.: Per la sostituzione del LED contattare l'azienda iGuzzini.
EN N.B.: For information on LED replacement please contact iGuzzini.
FR N.B.: Pour procéder au remplacement de la LED, adressez-vous à la société iGuzzini.
DE N.B.: Bezüglich des Austausches der LED kontaktieren Sie bitte die Firma iGuzzini.
NL N.B.: Voor het vervangen van de LED neemt u contact op met het bedrijf iGuzzini.
ES NOTA: Para sustituir el LED llame a la empresa iGuzzini.
DA N.B.: For udskiftning af lysdioden, skal man kontakte iGuzzini.
NO N.B.: For informasjon om skifte av LED, vennligst ta kontakt med iGuzzini.
SV OBS! För byte av lysdioden, kontakta företaget iGuzzini.
RU ПРИМЕЧАНИЕ: Для замены СИДов обращайтесь в компанию iGuzzini.
ZH 注意：如需LED更换的信息，请联系iGuzzini
AR تنبيه: لاستبدال الضوء LED اتصل بشركة iGuzzini



IT o di protezione danneggiato, richiedendo le specifiche tecniche al costruttore. Non utilizzare l'apparecchio senza lo schermo. Attenzione agli oggetti deteriorabili dai raggi U.V.
EN Replace the damaged protective screen, requesting the technical specifications from the manufacturer. Do not use the luminaire without the screen. Be careful of the objects that deteriorate when exposed to UV rays.
FR Remplacez l'écran de protection endommagé en demandant au fabricant les spécifications techniques correspondantes. N'utilisez pas l'appareil sans écran. Attention aux objets craignant les rayons U.V.
DE Ein beschädigter Schutzschirm muß ersetzt werden. Verlangen Sie vom Hersteller Angaben hinsichtlich der technischen Daten. Die Leuchte darf auf keinen Fall ohne diesen Schirm eingesetzt werden. Vorsicht bei Artikeln, die durch UV-Strahlen beschädigt werden könnten.
NL Vervang het protectiescherm als het beschadigd is en verlang van de fabrikant de juiste technische eigenschappen. Gebruik het apparaat niet zonder het scherm. Wees voorzichtig met voorwerpen die door de ultraviolette stralen bedorven kunnen worden.
ES Sustituir la pantalla de protección dañada solicitando las respectivas especificaciones técnicas al fabricante. No utilizar el aparato sin la pantalla. Cuidado con los objetos deteriorables por los rayos ultravioletas.
DA Udskift en beskadiget beskyttelsesskærm; og spørg fabrikanten til råds vedrørende de tekniske detaljer. Brug ikke apparatet uden skærm. Vær opmærksom på genstande, der kan nedbrydes af U.V.-stråler.
NO Skift ut den skadete verneskjermen, idet du ber om de tekniske spesifikasjonene hos produsenten. Ikke bruk apparatet uten skjerm. Pass på de gjenstandene som kan skades av U.V.-stråler.
SV Byt ut skadade skyddsskärmar. Rådfråga tillverkaren om tekniska specifikationer. Använd inte utrustningen utan skärmen. Var försiktig med föremål som kan skadas av U.V.-strålar.
RU Замените поврежденный защитный экран, запросив у производителя технические спецификации. Не использовать прибор без экрана. Обращайте внимание на предметы, которые могут быть повреждены под воздействием УФ излучения.
ZH 更换损坏的保护屏，向生产商索要技术规格。请勿使用无保护屏的光源。请勿使用无保护屏的使用灯具。注意那些受紫外线照射易损坏的物品。
قم بتبديل شاشة الحماية التالفة، واطلب التحديدات التقنية من المصنع. لا تستخدم التركيبية الضوئية بدون الشاشة.
AR احذر من تلف العناصر عند تعرضها للأشعة فوق البنفسجية.

Bluetooth
version

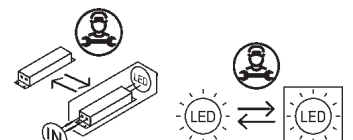
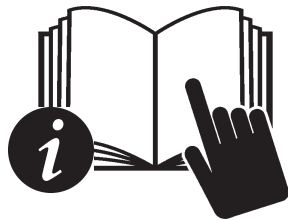

Headquarters iGuzzini illuminazione spa
via Mariano Guzzini, 37 - 62019 Recanati Italy

App  GET IT ON 





App
"iGuzzini Smart Light 2"





<https://qrco.de/bdf6nh>

PHONE/DEVICE OK?



<https://qrco.de/bdDY75>



Video tutorial
O.T.A UPDATE
(over the Air)

IT La iGuzzini si riserva, a sua discrezione, il diritto di modificare ed aggiornare le proprie app. La iGuzzini si esime da ogni responsabilità per eventuali incompatibilità dei dispositivi dovute alle modifiche e agli aggiornamenti apportati dalla iGuzzini sulle proprie app.

EN iGuzzini reserves the right to change and update its apps at its own discretion. iGuzzini accepts no liability whatsoever for the eventual incompatibility of devices caused by changes or updates made by iGuzzini to its apps.

FR iGuzzini se réserve, si elle le juge opportun, le droit de modifier et de mettre à jour ses applications. iGuzzini décline toute responsabilité en cas d'incompatibilité des dispositifs due aux modifications et aux mises à jour qu'elle aura effectuées sur ses applications.

DE iGuzzini behält sich nach eigener Maßgabe das Recht vor, die eigenen Apps zu ändern und zu aktualisieren. iGuzzini übernimmt keine Haftung für die eventuelle Inkompatibilität von Geräten im Zuge von Änderungen und Aktualisierungen durch iGuzzini an seinen Apps.

NL iGuzzini behoudt zich het recht voor om haar apps naar eigen goeddunken te wijzigen en updaten. iGuzzini acht zich niet aansprakelijk voor de eventuele incompatibiliteit tussen de apparaten wegens wijzigen en updates die iGuzzini aan haar apps heeft verricht.

ES iGuzzini se reserva, a su exclusiva discreción, el derecho a modificar y actualizar sus aplicaciones. iGuzzini se exime de toda responsabilidad por incompatibilidad de los dispositivos debida a las modificaciones y las actualizaciones realizadas por iGuzzini a sus aplicaciones.

DA iGuzzini forbeholder sig rettigheden til, efter eget skøn, at modificere og opdatere sine app. iGuzzini fraskriver sig ethvert ansvar for anordningernes eventuelle inkompatibilitet, som skyldes de modifikationer og opdateringer iGuzzini måtte udføre på sine app.

NO iGuzzini forbeholder seg retten til, etter eget skjønn, å endre og oppdatere appene sine. iGuzzini fritar seg fra ethvert ansvar for enhver inkompatibilitet av enhetene på grunn av endringene og oppdateringene som er gjort av iGuzzini på appene sine.

SV Företaget iGuzzini förbehåller sig rätten att efter eget gottfinnande ändra och uppdatera sina appar. Företaget iGuzzini avsäger sig alla ansvarsskyldigheter för eventuella inkompatibiliteter för anordningarna, orsakade av uppdateringar som iGuzzini gjort på sina appar.

RU Компания iGuzzini оставляет за собой право по собственному усмотрению изменять и обновлять свои приложения. Компания iGuzzini снимает с себя ответственность любого рода за возможную несовместимость устройств из-за изменений и обновлений, внесенных iGuzzini в свои приложения.

ZH iGuzzini保留自行决定更改和更新其App应用程序的权利。对于iGuzzini在其App应用程序上进行的更改和更新而导致的设备不兼容，iGuzzini不承担任何责任。

IT La iGuzzini non garantisce la compatibilità del sistema Quick BLE con i prodotti DALI di altri produttori.

EN iGuzzini does not guarantee that the Quick BLE system is compatible with the DALI products of other manufacturers.

FR iGuzzini ne garantit pas la compatibilité du système Quick BLE avec les produits DALI d'autres fabricants.

DE iGuzzini garantiert nicht für die Kompatibilität des Quick BLE-Systems mit DALI-Produkten anderer Hersteller.

NL iGuzzini kan de compatibiliteit van het Quick BLE-systeem met DALI-producten van andere fabrikanten niet waarborgen.

ES iGuzzini no garantiza la compatibilidad del sistema Quick BLE con los productos DALI de otros fabricantes.

DA iGuzzini giver ingen garanti for Quick BLE systemets kompatibilitet med DALI produkter fra andre producenter.

NO iGuzzini garanterer ikke Quick BLE-systemets kompatibilitet med DALI-produkter fra andre produsenter.

SV iGuzzini garanterar inte att systemet Quick BLE är kompatibelt med DALI-produkter från andra tillverkare.

RU Компания iGuzzini не гарантирует совместимость системы Quick BLE с изделиями DALI других производителей.

ZH iGuzzini不保证Quick BLE系统与其他制造商的DALI产品的兼容性。

IT «Il sistema Quick BLE e l'app Smart Light 2, salvo i dati dell'account utente e la configurazione dell'impianto su cloud: dopo 1 anno di completa inattività dell'account verso il cloud, tutti i dati vengono cancellati»

EN «The Quick BLE system and Smart Light 2 app, save the user's account data and system configuration in a cloud. If the account in the cloud is left completely inactive for 1 year, all the data is deleted»

FR «Le système Quick BLE et l'application Smart Light 2 enregistrent les données du compte utilisateur et la configuration de l'installation sur cloud : au bout d'un an de totale inactivité du compte vers le cloud, toutes les données seront supprimées».

DE «Das Quick BLE-System und die App Smart Light 2 speichern die Daten des Kundenaccounts und die Konfiguration der Anlage in der Cloud. Nach einem Jahr vollständiger Cloud-Inaktivität des Accounts werden die Daten gelöscht»

NL «Het Quick BLE-systeem en de app Smart Light 2 slaan de gegevens van het account van de gebruiker en de configuratie van de installatie op in de cloud: alle gegevens worden gewist als het account 1 jaar lang geen enkele handeling richting de cloud verricht»

ES «El sistema Quick BLE y la aplicación Smart Light 2 guardan los datos de la cuenta de usuario y la configuración del sistema en la nube: después de 1 año de inactividad total de la cuenta hacia la nube, se eliminan todos los datos»

DA «Systemet Quick BLE og app'en Smart Light 2 gemmer brugerkontoens data og anlæggets konfiguration på platformen cloud: Alle dataene slettes efter 1 år uden nogen aktivitet fra kontoen til cloud»

NO «Systemet Quick BLE appen Smart Light 2, lagrer dataene fra brukerkontoen og konfigurasjonen av systemet på skyen: etter 1 år med fullstendig inaktivitet mellom kontoen og skyen vil alle dataene bli slettet»

SV «Systemet Quick BLE och appen Smart Light 2 sparar användarkontots data och systemkonfigurationen i molnet: när kontot varit totalt inaktivt i förhållande till molnet under 1 års tid kommer all data att raderas»

RU «Система Quick BLE и приложение Smart Light 2 сохраняют данные учетной записи пользователя и конфигурацию системы в облаке: после 1 года полного бездействия учетной записи в облаке все данные удаляются»

ZH Quick BLE系统和Smart Light 2应用程序可将用户的账户数据和系统配置保存到云端：如果1年内该账户到云端之间没有任何操作，所有的数据将被删除。

IT Attenzione: per il corretto funzionamento degli "scheduler" è necessario che il bridge BLE e le interfacce BLE siano alimentati almeno 5 minuti prima dell'orario di attivazione della prima scena luminosa e che la WiFi sia disponibile.

EN Important: for "schedulers" to operate correctly, the BLE bridge and BLE interfaces must be powered up at least 5 minutes before the moment the first light scenario is activated and a WiFi network must be available.

FR Attention : pour un fonctionnement correct des planificateurs, le bridge BLE et les interfaces BLE doivent être alimentés au moins 5 minutes avant l'heure d'activation du premier scénario lumineux et le WiFi doit être disponible.

DE Achtung: Damit die "Scheduler" störungsfrei funktionieren, müssen die Bridge BLE und die Schnittstellen BLE mindestens 5 Minuten vor der Aktivierungszeit des ersten Beleuchtungsszenarios eingeschaltet werden und das WLAN muss verfügbar sein.

NL Opgelet, voor de correcte werking van de "schedulers" moeten de bridge BLE en de interfaces BLE minstens 5 minuten voor het tijdstip voor de activering van de eerste lichtscène worden gevoed en moet wifi beschikbaar zijn.

ES Atención: para que los "scheduler" funcionen correctamente es necesario que el puente BLE y las interfaces BLE estén alimentados por lo menos 5 minutos antes de la hora a la que se activa la primera escena luminosa y que la WiFi esté disponible.

DA OBS: Det er nødvendigt, at BLE-jumperen og BLE-grænsefladerne forsynes i mindst 5 minutter før tidspunktet for aktivering af den første lyscene og at WiFi står til rådighed, for at opnå en korrekt funktion af udstyrets "scheduler".

NO Obs: for korrekt funksjon av "planleggeren" må broen BLE og grensesnittene BLE få strømforsyning i minst 5 minutter før klokkeslettet for aktivering av den første lysscenen og WiFi er tilgjengelig.

SV Observera: för att dessa "scheduler" ska fungera korrekt måste BLE-bryggan och BLE-gränssnitten strömförsörjas minst 5 minuter innan den första ljusinstallationen aktiveras, och det måste finnas ett tillgängligt WiFi.

RU Внимание: для правильной работы программ управления необходимо подать питание на мост BLE и интерфейсы BLE не менее чем за 5 минут до момента включения первого светового сценария; требуется также наличие WiFi.

ZH 注意：为使调度器正常工作，电桥BLE和接口BLE必须在激活第一个灯光场景至少5分钟前通电，并且WiFi必须可用。

App «zone» ADDRESSED

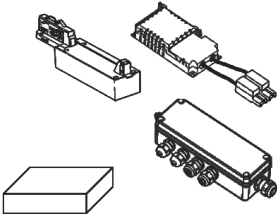
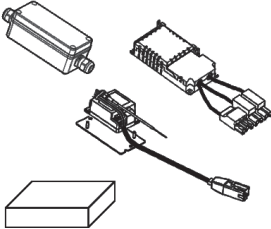
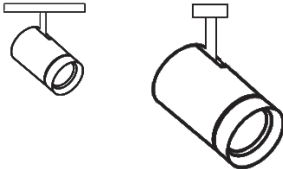
INTERFACES BLE-DALI 32 	INTERFACES BLE-DALI 4 	LUMINAIRE BLE 
Type A MAX 32 DALI addresses each interface	Type B MAX 4 DALI addresses each interface	Type C BLE luminaire (monoch./TW)

Max 320 DALI Addresses for app «zone» (network)

Max 320 DALI Addresses for app «zone» (network)

Max 320 BLE luminaires for app «zone» (network)

Combination interfaces/DALI addresses/luminaires for each app «zone»



(n. of Type A x n. of DALI addresses) + (n. of Type B x n. of DALI addresses) + (n. of Type C) ≤ 320

Example1: (n.11 Type A x n. 23 addr.) + (n.8 Type B x n. 3 addr.) + (n.20 Type C) = 297 ✓

Example2: (n.8 Type A x n. 31 addr.) + (n.0 Type B x n. 0 addr.) + (n.115 Type C) = 363 ✗

MESH OPERATION

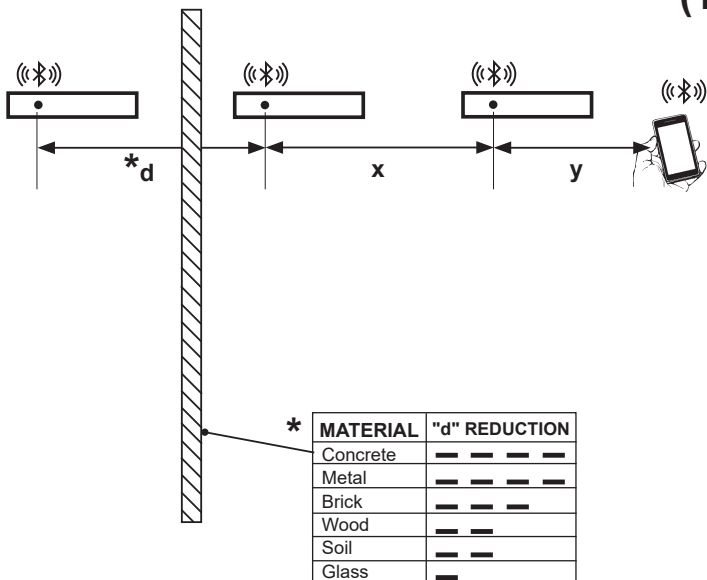

- (1)** IT La distanza massima dipende anche dalla disposizione nello spazio e dalla presenza di altri segnali wireless. Si raccomanda di verificare l'affidabilità della comunicazione nella posizione di installazione effettiva mediante un semplice mock-up.
- EN** The maximum distance is influenced also by the space layout and the presence of other wireless signals. It's recommended to test the reliability of the communication at the actual installation site with a simple mock-up.
- FR** La distance maximale dépend aussi de la disposition de l'espace et de la présence d'autres signaux sans fil. Il est recommandé de s'assurer de la fiabilité de la communication dans la position réelle d'installation avec un simple Cellule Témoin.
- DE** Die maximale Entfernung hängt auch von der Raumaufteilung und dem Vorhandensein anderer Wireless-Signale ab. Wir empfehlen, die Zuverlässigkeit der Übertragung am tatsächlichen Installationsort mithilfe eines einfachen Mock-up zu testen.
- NL** De maximumafstand hangt ook af van de ruimte en of andere draadloze signalen aanwezig zijn. Het wordt aanbevolen om de betrouwbaarheid van de communicatie op de daadwerkelijke installatieplek aan de hand van een eenvoudig mock-up.
- ES** La distancia máxima también depende de la distribución del espacio y de la presencia de otras señales inalámbricas. Se recomienda comprobar la fiabilidad de la comunicación en el punto de instalación real utilizando un simple mock-up.
- DA** Den maksimale afstand afhænger også af omgivelsernes indretning og af andre tilstedeværende trådløse signaler. Det er vigtigt at kontrollere forbindelsens pålidelighed på det reelle installationssted vha. en enkelt mock-up.
- NO** Maksimumavstanden påvirkes også av plasslayouten og forekomsten av andre trådløse signaler. Vi anbefaler at du tester påliteligheten til kommunikasjonen på det aktuelle installasjonsstedet med en enkel mock-up.
- SV** Det maximala avståndet beror också på utrymmets layout och på om det förekommer andra trådlösa signaler. Vi rekommenderar att man testat kommunikationens tillförlitlighet på den faktiska installationsplatsen med hjälp av en enkel mock-up.
- RU** Максимальное расстояние зависит также от расположения помещения и наличия других беспроводных сигналов. Рекомендуется проверять надежность связи в месте установки при помощи простой Мокап.
- ZH** 最大距离还受到空间布局和其他无线信号的影响。因此我们建议在实际安装现场先用简单的模型测试通信的可靠性。

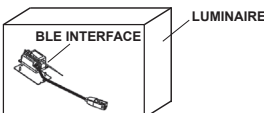
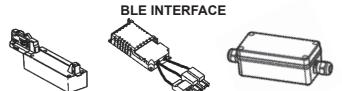
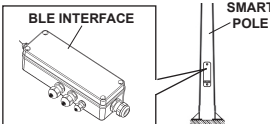
INTEGRATED ACCESSORIES ON PRODUCTS	X (m) ⁽¹⁾	Y (m) ⁽¹⁾
BLE PRODUCT 	8	20
ACCESSORY INTERFACE INTEGRATED INSIDE THE PRODUCTS 		
INTERFACE BLE/DALI 	INDOOR 30 OUTDOOR 50	20
INTERFACE BLE/DALI FOR SMART POLE 	POLE ART. X730 - X731 - X732 X733 - X734 - X735 X736 - X737 <hr/> S989 - S990 - S991 S992 - S993 - S994 S995 - S996	25 50

IT Il fabbricante/importatore, iGuzzini Illuminazione, dichiara che i prodotti BLE sono conformi alla direttiva 2014/53/UE. Il testo completo della dichiarazione di conformità UE è disponibile al seguente indirizzo Internet: <http://www.iguzzini.com>.

EN The manufacturer/importer, iGuzzini Illuminazione, hereby declares that its BLE products comply with EU regulation 2014/53/UE. The complete EU Declaration of Conformity is available at the following internet address: <http://www.iguzzini.com>.

FR Le fabricant/l'importateur, iGuzzini Illuminazione, déclare que les produits BLE sont conformes à la directive 2014/53/UE. Le texte intégral de la déclaration de conformité UE est disponible à l'adresse Internet <http://www.iguzzini.com>.

DE Der Hersteller/Importeur iGuzzini Illuminazione erklärt, dass die Produkte BLE der Richtlinie 2014/53/EU entsprechen. Der vollständige Wortlaut der EU-Konformitätserklärung kann unter <http://www.iguzzini.com> eingesehen werden.

NL De fabrikant/importeur iGuzzini Illuminazione verklaart dat de producten BLE overeenstemmen met de richtlijn 2014/53/EU. De volledige tekst van de EU-verklaring van overeenstemming is verkrijgbaar op het volgende internetadres: <http://www.iguzzini.com>

ES El fabricante/importador, iGuzzini Illuminazione, declara que los productos BLE son conformes con la directiva 2014/53/UE. El texto completo de la declaración de conformidad UE se puede consultar en la siguiente dirección de Internet: <http://www.iguzzini.com>.



DA Fabrikanten /importøren, iGuzzini Illuminazione (iGuzzini Belysning) erklærer, at BLE-produkterne stemmer overens med direktiv 2014/53/EU. EU-overensstemmelseserklæringens fulde tekst står til rådighed på den følgende Internetadresse: <http://www.iguzzini.com>

NO Produsenten/importøren, iGuzzini Illuminazione, erklærer at produktene BLE er i samsvar med direktivet 2014/53/EU. Den fullstendige teksten til samsvarserklæringen er tilgjengelig på følgende internetadresse: <http://www.iguzzini.com>

SV Tillverkaren/importören, iGuzzini Illuminazione, försäkrar att nedanstående BLE-produkter är överensstämmande med direktiv 2014/53/EU. Den fullständiga texten i EU-försäkran om överensstämmelse finns tillgänglig på följande Internetadress : <http://www.iguzzini.com>

RU Изготовитель/импортер iGuzzini Illuminazione заявляет, что изделия BLE отвечают требованиям директивы 2014/53/UE. С полным текстом Декларации соответствия ЕС можно ознакомиться по следующему адресу в Интернете: <http://www.iguzzini.com>

ZH 制造商/进口商 iGuzzini Illuminazione 照明公司 声明 产品 BLE 符合 指令 2014/53/UE 的要求。欧 盟 符合 性 声明 的 完整 内 容 可 到 以 下 网 址 查 阅 : <http://www.iguzzini.com>

art. PA59
www.iguzzini.com/PA59

art. X746
www.iguzzini.com/X746

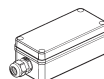
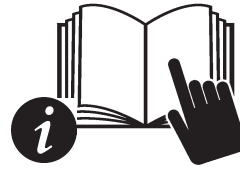
Integrated Beacon for Smart Services Protocols: iBeacon, Eddystone, AltBeacon



www.iguzzini.com/smart-services

IT Scansionare il codice QR o visitare www.iguzzini.com per ulteriore documentazione tecnica.

EN Scan the QR Code or visit www.iguzzini.com for more technical documentation.

FR Numériser le code QR ou consulter www.iguzzini.com pour davantage de documentation technique.

DE QR-Code scannen oder www.iguzzini.com für weitere technische Unterlagen aufrufen.

NL Escanear el código QR o visitar la página www.iguzzini.com para obtener más documentación técnica.

ES Scan de QR-code of bezoek www.iguzzini.com voor meer technische documentatie.

DA Scan QR-koden eller gå til www.iguzzini.com for yderligere teknisk dokumentation.

NO Skann QR-koden eller besøk www.iguzzini.com for mer teknisk dokumentasjon.



SV Skanna QR-koden eller gå till www.iguzzini.com för ytterligare teknisk dokumentation.



RU Сканируйте QR-код или обратитесь к www.iguzzini.com за дополнительной технической документацией.

ZH 扫描二维码或浏览网站 www.iguzzini.com 获取更多的技术文档。



BLUETOOTH PUSH-BUTTON

art. PB31





**BLE INTERFACE
BLE LUMINAIRE
BLE DEVICE**

**BLE INTERFACE
BLE LUMINAIRE
BLE DEVICE**

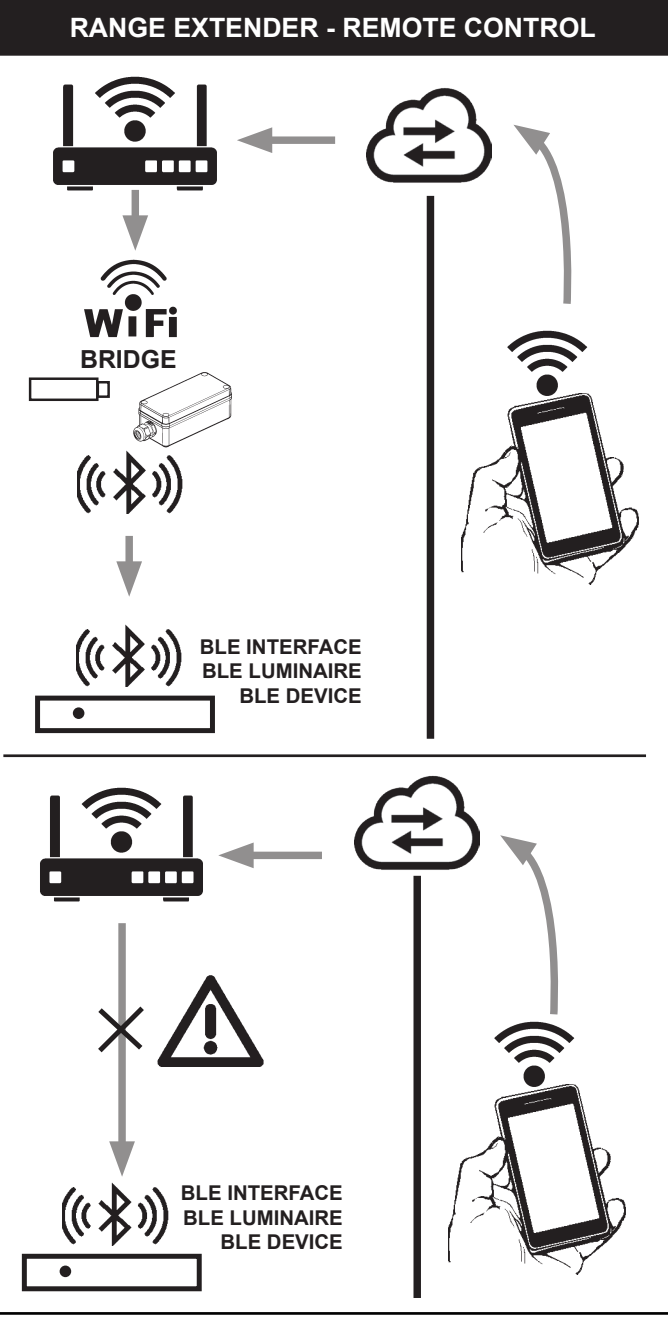

SYSTEM MANUAL

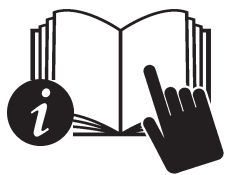

<https://qrco.de/bdDtjG>

2.510.640.05 IS14509/05	iGuzzini	corrente assorbita absorbed current courant absorbé Stromaufnahme stroompname corriente absorbida absorberet strøm absorbert strøm tillförd ström поглощаемая мощность 电源电流 التيار الممتص A
ART.		
QP07 - QP08 - RC44 - RC45		0.33
QP18 - QP22 - QX01 - RC58 - RC62 - RC66 004B - 008B - 012B - 016B - 020B		0.28
QP10 - QP11 - QP13 - QP14 - QW99 - QX00 RC47 - RC48 - RC50 - RC51 - RC53 - RC54 000B - 002B - 003B - 990A - 991A - 993A 994A - 996A - 997A - 999A		0.41
QP15 - QP16 - QP17 - QP26 RC55 - RC56 - RC57 - RC73		0.46
QP19 - QP20 - QP21 - QP23 - QP24 - QP25 QP27 - QP28 - QX02 - QX03 - QX04 - QX08 RC59 - RC60 - RC61 - RC63 - RC64 - RC65 RC67 - RC68 - RC69 - RC74 - RC75 - RC76 005B - 006B - 007B - 009B - 010B - 011B 013B - 014B - 015B - 017B - 018B - 019B 021B - 022B - 023B - 029B - 030B - 031B 032B - 033B		0.47
QN66 - QN71 - QN86 - QN91 - 190B - 191B 192B - 193B		0.26
QN67 - QN68 - QN69 - QN70 - QN72 - QN73 QN74 - QN75 - QN87 - QN88 - QN89 - QN90 QN92 - QN93 - QN94 - QN95 - 194B - 195B 196B - 197B - 198B - 199B - 200B - 201B - 202B 203B - 204B - 205B - 206B - 207B - 208B - 209B		0.40
QP06 - QP09 - QP12 - QW98 - RC43 - RC46 RC49 - RC52 - 989A - 992A - 995A - 998A - 001B		0.37

2.510.640.05 IS14509/05	iGuzzini	corrente assorbita absorbed current courant absorbé Stromaufnahme stroompname corriente absorbida absorberet strøm absorbert strøm tillförd ström поглощаемая мощность 电源电流 التيار الممتص A
ART.		
QP07 - QP08 - RC44 - RC45		0.33
QP18 - QP22 - QX01 - RC58 - RC62 - RC66 004B - 008B - 012B - 016B - 020B		0.28
QP10 - QP11 - QP13 - QP14 - QW99 - QX00 RC47 - RC48 - RC50 - RC51 - RC53 - RC54 000B - 002B - 003B - 990A - 991A - 993A 994A - 996A - 997A - 999A		0.41
QP15 - QP16 - QP17 - QP26 RC55 - RC56 - RC57 - RC73		0.46
QP19 - QP20 - QP21 - QP23 - QP24 - QP25 QP27 - QP28 - QX02 - QX03 - QX04 - QX08 RC59 - RC60 - RC61 - RC63 - RC64 - RC65 RC67 - RC68 - RC69 - RC74 - RC75 - RC76 005B - 006B - 007B - 009B - 010B - 011B 013B - 014B - 015B - 017B - 018B - 019B 021B - 022B - 023B - 029B - 030B - 031B 032B - 033B		0.47
QN66 - QN71 - QN86 - QN91 - 190B - 191B 192B - 193B		0.26
QN67 - QN68 - QN69 - QN70 - QN72 - QN73 QN74 - QN75 - QN87 - QN88 - QN89 - QN90 QN92 - QN93 - QN94 - QN95 - 194B - 195B 196B - 197B - 198B - 199B - 200B - 201B - 202B 203B - 204B - 205B - 206B - 207B - 208B - 209B		0.40
QP06 - QP09 - QP12 - QW98 - RC43 - RC46 RC49 - RC52 - 989A - 992A - 995A - 998A - 001B		0.37

2.510.640.05 IS14509/05	iGuzzini	corrente assorbita absorbed current courant absorbé Stromaufnahme stroompname corriente absorbida absorberet strøm absorbert strøm tillförd ström поглощаемая мощность 电源电流 التيار الممتص A
ART.		
QP07 - QP08 - RC44 - RC45		0.33
QP18 - QP22 - QX01 - RC58 - RC62 - RC66 004B - 008B - 012B - 016B - 020B		0.28
QP10 - QP11 - QP13 - QP14 - QW99 - QX00 RC47 - RC48 - RC50 - RC51 - RC53 - RC54 000B - 002B - 003B - 990A - 991A - 993A 994A - 996A - 997A - 999A		0.41
QP15 - QP16 - QP17 - QP26 RC55 - RC56 - RC57 - RC73		0.46
QP19 - QP20 - QP21 - QP23 - QP24 - QP25 QP27 - QP28 - QX02 - QX03 - QX04 - QX08 RC59 - RC60 - RC61 - RC63 - RC64 - RC65 RC67 - RC68 - RC69 - RC74 - RC75 - RC76 005B - 006B - 007B - 009B - 010B - 011B 013B - 014B - 015B - 017B - 018B - 019B 021B - 022B - 023B - 029B - 030B - 031B 032B - 033B		0.47
QN66 - QN71 - QN86 - QN91 - 190B - 191B 192B - 193B		0.26
QN67 - QN68 - QN69 - QN70 - QN72 - QN73 QN74 - QN75 - QN87 - QN88 - QN89 - QN90 QN92 - QN93 - QN94 - QN95 - 194B - 195B 196B - 197B - 198B - 199B - 200B - 201B - 202B 203B - 204B - 205B - 206B - 207B - 208B - 209B		0.40
QP06 - QP09 - QP12 - QW98 - RC43 - RC46 RC49 - RC52 - 989A - 992A - 995A - 998A - 001B		0.37

2.510.640.05 IS14509/05	iGuzzini	corrente assorbita absorbed current courant absorbé Stromaufnahme stroompname corriente absorbida absorberet strøm absorbert strøm tillförd ström поглощаемая мощность 电源电流 التيار الممتص A
ART.		
QP07 - QP08 - RC44 - RC45		0.33
QP18 - QP22 - QX01 - RC58 - RC62 - RC66 004B - 008B - 012B - 016B - 020B		0.28
QP10 - QP11 - QP13 - QP14 - QW99 - QX00 RC47 - RC48 - RC50 - RC51 - RC53 - RC54 000B - 002B - 003B - 990A - 991A - 993A 994A - 996A - 997A - 999A		0.41
QP15 - QP16 - QP17 - QP26 RC55 - RC56 - RC57 - RC73		0.46
QP19 - QP20 - QP21 - QP23 - QP24 - QP25 QP27 - QP28 - QX02 - QX03 - QX04 - QX08 RC59 - RC60 - RC61 - RC63 - RC64 - RC65 RC67 - RC68 - RC69 - RC74 - RC75 - RC76 005B - 006B - 007B - 009B - 010B - 011B 013B - 014B - 015B - 017B - 018B - 019B 021B - 022B - 023B - 029B - 030B - 031B 032B - 033B		0.47
QN66 - QN71 - QN86 - QN91 - 190B - 191B 192B - 193B		0.26
QN67 - QN68 - QN69 - QN70 - QN72 - QN73 QN74 - QN75 - QN87 - QN88 - QN89 - QN90 QN92 - QN93 - QN94 - QN95 - 194B - 195B 196B - 197B - 198B - 199B - 200B - 201B - 202B 203B - 204B - 205B - 206B - 207B - 208B - 209B		0.40
QP06 - QP09 - QP12 - QW98 - RC43 - RC46 RC49 - RC52 - 989A - 992A - 995A - 998A - 001B		0.37

- I Istruzioni per le operazioni di servizio per l'apparecchio di illuminazione**
GB Instructions on luminaire service operations
F Instructions pour les opérations de service du luminaire
D Wartungsanleitung für die Leuchte
NL Instructies voor de onderhoudsoperaties op de verlichtingsarmatuur
E Instrucciones para las operaciones de servicio del aparato de alumbrado
DK Anvisninger i serviceindgreb på belysningsarmatur
N Anvisninger for betjening av lysapparatet
S Instruktioner för användning av belysningsanordningen
RUS Инструкции по эксплуатации осветительного прибора
CN 照明装置检修操作说明

Sostituire la lampada parzialmente esausta
 Replace the partly exhausted lamp
 Remplacer la lampe partiellement épuisée
 Die teilweise erschöpfte Lampe austauschen
 Vervang de gedeeltelijk lege lamp
 Sustituir la lámpara parzialmente agotada
 Udskift den delvist udtjente pære
 Skifte ut den delvis utbrænte lyspæren
 Byt ut den delvis förbrukade lampan
 Замена частично отработанной лампочки
 更换部分老化的灯泡



Spegnimento
 Switch it off
 Extinction
 Ausschaltung
 Uitschakeling
 Apagado
 Slukning
 Slukking
 Släckning
 Выключение
 关灯

Interrompere l'alimentazione dell'apparecchio
 Cut the power supply to the luminaire
 Couper l'alimentation du luminaire
 Stromversorgung der Leuchte unterbrechen
 Onderbreek de voeding van het apparaat
 Interrumpir la alimentación del aparato
 Afbryd armaturets strømforsyning
 Avbryt strømtilførselen til apparatet
 Koppla från anordningens strömförsörjning
 Отключить электропитание прибора
 中断装置供电



Aprire l'apparecchio
 Open the fixture
 Ouvrir le luminaire
 Das Gerät öffnen
 Open het apparaat
 Abrir el aparato
 Åbn armaturet
 Åpne apparatet
 Öppna anordningen
 Раскрыть прибор
 打开装置



Rimuovere la lampada esausta
 Remove the exhausted lamp
 Retirer la lampe épuisée
 Die alte Lampe entnehmen
 Verwijder de lege lamp
 Quitar la lámpara agotada
 Tag den udtjente pære ud
 Fjerne den utbrænte lyspæren
 Ta bort den förbrukade lampan
 Вынуть старую лампочку
 取出老化的灯泡

Portarla in un centro di riciclaggio
 Carry it to a recycling centre
 La porter dans une déchetterie pour son recyclage
 Ordnungsgemäß entsorgen
 Breng de lamp naar een recyclingcentrum
 Llevarla a un centro de reciclaje
 Aflever den på en genbrugsstation
 Lever den til en miljøstasjon
 Lämna in den till en återvinningsanläggning
 Сдать ее в пункт приема утильсырья
 将其送往回收中心



Inserire la nuova lampada
 Introduce the new lamp
 Installer la lampe neuve
 Die neue Lampe einsetzen
 Doe de nieuwe lamp op zijn plek
 Montar la nueva lámpara
 Sæt den nye pære i
 Sette i den nye pæren
 Sätt i den nya lampan
 Вставить новую лампочку
 装入新灯泡

Inserire la nuova lampada nel portalampana
 Fit the new lamp into the socket
 Installer la nouvelle lampe dans le support de lampe
 Die neue Lampe in den Sockel einsetzen
 Doe de nieuwe lamp in de lamphouder
 Montar la nueva lámpara en el portalampana
 Sæt den nye pære i fatningen
 Sette den nye pæren inn i lampeholderen
 Sätt i den nya lampan i lamphållaren
 Вставить новую лампочку в патрон
 将新灯泡插入灯泡架中



Riposizionare ottica
 Re-place the optic
 Remettre l'optique à sa place
 Die Optik wieder einsetzen
 Doe de optiek weer op zijn plaats
 Volver a montar la óptica
 Sæt den optiske enhed på plads
 Innstille linsen
 Flytta om optiken
 Отрегулировать линзы
 重新定位光头



Effettuare prova di funzionamento
 Perform operative test
 Procéder à un essai de fonctionnement
 Eine Funktionsprüfung durchführen
 Controleer de correcte werking
 Hacer una prueba de funcionamiento
 Afprøv funktionen
 Prové om den fungerer
 Utför funktionstest
 Выполнить проверку исправности работы
 执行功能测试



- I Istruzioni per la pulizia dell'apparecchio di illuminazione
 GB Instructions on luminaire cleaning operations
 F Instructions pour le nettoyage du luminaire
 D Anweisungen zur Reinigung der Leuchte
 NL Instructies voor de reiniging van de verlichtingsarmatuur
 E Instrucciones para limpiar el aparato de alumbrado
 DK Anvisninger i rengøring af belysningsarmaturet
 N Anvisninger for rengjøring av lysapparatet
 S Instruktioner för rengöring av belysningsanordningen
 RUS Инструкции по чистке осветительного прибора
 CN 照明装置清洁说明

Pulire l'apparecchio
 Clean the fixture
 Nettoyer le luminaire
 Das Gerät reinigen
 Reinig het apparaat
 Limpiar el aparato
 Rengør armaturet
 Rengjøre apparatet
 Rengör anordningen
 Чистка прибора
 清洁装置



Spegnimento
 Switch it off
 Extinction
 Ausschaltung
 Uitschakeling
 Apagado
 Slukning
 Slukking
 Släckning
 Выключение
 关灯

Interrompere l'alimentazione dell'apparecchio
 Cut the power supply to the luminaire
 Couper l'alimentation du luminaire
 Stromversorgung der Leuchte unterbrechen
 Onderbreek de voeding van het apparaat
 Interrumpir la alimentación del aparato
 Afbryd armaturets strømforsyning
 Avbryt strømtilførselen til apparatet
 Koppla från anordningens strömförsörjning
 Отключить электропитание прибора
 中断装置供电



Spolverare l'ottica esterna
 Remove dust from the external optic
 Dépoussiérer l'optique extérieure
 Die externe Optik abstauben
 Stof de externe optiek af
 Quitar el polvo de la óptica exterior
 Tør støvet af den udvendige optiske enhed
 Fjerne støv fra den eksterne lysenheden
 Damma av den yttre optiken
 Вытереть пыль с внешней стороны линз
 为外侧镜头掸尘



Lavare l'ottica esterna
 Wash the external optic
 Laver l'optique extérieure
 Die externe Optik waschen
 Was de externe optiek
 Lavar la óptica exterior
 Vask den udvendige optiske enhed
 Vaske den eksterne lysenheden
 Rengör den yttre optiken
 Вымыть линзы с внешней стороны
 清洁外镜头



Rimuovere l'ottica
 Remove the optic
 Retirer l'optique
 Die Optik abnehmen
 Verwijder de optiek
 Quitar la óptica
 Tag den optiske enhed af
 Fjerne lysenheden
 Ta bort optiken
 Снять линзы
 取下镜头



Pulire la parte interna dell'apparecchio di illuminazione
 Clean the inside of the fixture
 Nettoyer l'intérieur du luminaire
 Die Innenseite der Leuchte reinigen
 Reinig de binnenzijde van de verlichtingsarmatuur
 Limpiar el interior del aparato de alumbrado
 Rengør belysningsarmaturets indvendige dele
 Rengjøre lysapparatet innvendig
 Rengör belysningsanordningen invändigt
 Протереть осветительный прибор изнутри
 清洁照明装置内部



Riposizionare ottica
 Re-place the optic
 Remettre l'optique à sa place
 Die Optik wieder einsetzen
 Doe de optiek weer op zijn plaats
 Volver a montar la óptica
 Sæt den optiske enhed på plads
 Innstille linsen
 Flytta om optiken
 Отрегулировать линзы
 重新定位镜头



Effettuare prova di funzionamento
 Perform operative test
 Procéder à un essai de fonctionnement
 Eine Funktionsprüfung durchführen
 Controleer de correcte werking
 Hacer una prueba de funcionamiento
 Afprøv funktionen
 Prøve om den fungerer
 Utför funktionstest
 Выполнить проверку исправности работы
 执行功能测试

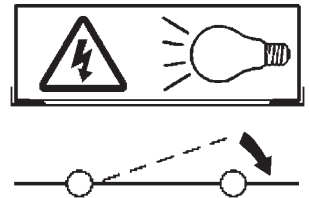

- I Istruzioni per il fine vita e lo smaltimento dei componenti**
GB Instructions on end-of-life and component disposal
F Instructions pour la gestion des composants en fin de vie et leur mise au rebut
D Anweisungen zur Entsorgung der Leuchtenkomponenten
NL Instructies voor het verwijderen van de armatuur en het recyclen van de onderdelen
E Instrucciones para el final de vida y la eliminación los componentes
DK Anvisninger i udtjent armatur og bortskaffelse af komponenter
N Anvisninger for endt levetid og avfallsbehandling av delene
S Instruktionser vid bortskaffning och kassering av komponenter
RUS Инструкции по утилизации прибора и его комплектующих по окончании его срока службы
CN 寿命期结束与零件废弃处置说明

Spegnimento
Switch it off
Extinction
Ausschaltung
Uitschakeling
Apagado
Slukning
Slukking
Släckning
Выключение
关灯

Interrompere l'alimentazione dell'apparecchio
Cut the power supply to the luminaire
Couper l'alimentation du luminaire
Stromversorgung der Leuchte unterbrechen
Onderbreek de voeding van het apparaat
Interrompirla alimentación del aparato
Afbryd armaturets strømforsyning
Avbryt strømtilførselen til apparatet
Koppla från anordningens strömförsörjning
Отключить электропитание прибора
中断装置供电



Rimuovere la/e lampada/e per la dismissione
Remove the lamp(s) for decommissioning
Retirer la(les) lampe(s) pour sa(leur) mise au rebut
Die Lampe/n ordnungsgemäß entsorgen
Verwijder de lamp(en) voor het recyclen
Quitar la(s) lámpara(s) para el desecho
Tag pæren/pærerne ud til bortskaffelse
Fjerne lampen/-e som skal kastes
Ta bort lampan/-orna för bortskaffningen
Вынуть лампочку/и для утилизации прибора
取出需要丢弃的灯泡



Rimuovere la batteria per la dismissione
Remove the battery for decommissioning
Retirer la batterie pour sa mise au rebut
Die Batterie ordnungsgemäß entsorgen
Verwijder de batterij voor het recyclen
Quitar la batería para el desecho
Tag batteriet ud til bortskaffelse
Fjerne batteriet som skal kastes
Ta bort batteriet för bortskaffningen
Вынуть батарейку для утилизации прибора
取出需要丢弃的电池



Rimuovere l'apparecchio per la dismissione
Remove the fixture for decommissioning
Enlever le luminaire pour sa mise au rebut
Das Gerät ordnungsgemäß entsorgen
Verwijder het apparaat voor het recyclen
Quitar el aparato para el desecho
Tag armaturet ud til bortskaffelse
Fjerne apparatet som skal kastes
Ta bort anordningen för bortskaffningen
Снять прибор для утилизации
取出需要丢弃的装置



Inviare i materiali ad un centro di raccolta
RAEE
Send the materials to a WEEE collection
centre
Envoyer les matériaux dans une déchetterie
DEEE
Die Materialien in einem WEEE-Zentrum
entsorgen
Zend de materialen naar een recyclingscentrum
voor de AEEA
Enviar los materiales a un centro de recogida
RAEE
Afløver materialerne på et indsamlingscenter
for elektronisk udstyr
Sende materialene til en miljøstasjon for
resirkulering av EE-avfall
Skicka materialet till en RAEE uppsamlingscentral
Сдать материалы в пункт приема утильсырья
将材料送往电气和电子垃圾回收中心

