

WIRING BOX

ART. X744 (series connection) **ART. X745** (parallel connection) **ART. X782** (ground connection)

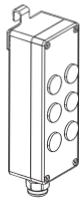
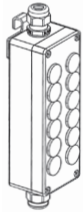

SMART POLES APPLICATION:

ART.	B		(L) m	X744		X745		X782		
	(A) Ømm	(B) Ømm		X744 + X743	X745 + X743	X744 + X743	X745 + X743	X782 + X743	X782 + X743	
X820 X821	S998 SA07	120	76	3,5	✗	✗	✓	✓	✗	✗
X822 X906	S997 S999	120	76	5	✗	✗	✓	✓	✗	✗
X730 S989	X734 S993	159	102	5	✗	✓	✓	✓	✓	✗
X731 S990	X735 S994	159	102	7	✗	✓	✓	✓	✓	✗
X732 S991	X736 S995	194	120	9	✗	✓	✓	✓	✓	✗
X733 S992	X737 S996	219	120	12	✓	✗	✓	✓	✓	✗

IT Attenzione:

La sicurezza dell'apparecchio e' garantita solo con l'uso appropriato delle seguenti istruzioni; pertanto e' necessario conservarle.

EN Warning:

The safety of this fixture is guaranteed only if you comply with these instructions; remember to conserve in a safe place.

FR Attention:

La sécurité de l'appareil n'est garantie qu'en cas d'utilisation correcte des instructions suivantes; il faut par conséquent les conserver.

DE Achtung:

Die sicherheit des gerätes wird nur durch sachgemässe befolgung nachstehender anweisungen gewährleistet; ihre aufbewahrung ist deshalb sehr wichtig.

NL Opgelet:

De veiligheid van dit toestel is slechts dan gegarandeerd als indien de volgende instructies strikt worden toegepast: daarom moet men ze ook bewaren.

ES Atencion:

La seguridad del aparato se garantiza solo cumpliendo cuidadosamente las siguientes instrucciones; por ello, es necesario conservarlas.

DA Bemærk:

Sikkerheden ved brug af armaturet kan kun garanteres, hvis disse anvisninger følges; sørg derfor for at gemme dem.

NO Advarsel:

Sikkerheten til dette apparatet garanteres kun hvis du overholder disse instruksjonene; husk å oppbevare dem på et trygt sted.

SV Observera:

Utrustningens säkerhet kan endast garanteras om dessa anvisningar respekteras i detalj. Spara därför dessa anvisningar för framtida konsultation.

RU Внимание:

Мы гарантируем безопасную эксплуатацию изделия только при соблюдении следующих инструкций; с этой целью необходимо сохранить данную брошюру.

ZH 警告:

为确保该装置安全, 请遵守操作指示; 并于安全场所放置。

تخدير:

لا يمكن ضمان سلامة هذا الجهاز إلا إذا التزمت بهذه التعليمات. يجب حفظها في مكان آمن.

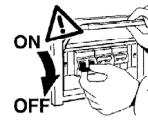

IT N.B.: Durante l'installazione del sistema rispettare scrupolosamente le norme impiantistiche vigenti.

EN N.B.: When installing the system, strictly comply with all regulations on installation in force.

FR N.B.: Lors de l'installation du système veuillez respecter rigoureusement les normes en vigueur en la matière.

DE N.B.: Beachten sie bei der installation des systems gewissenhaft die gültigen bestimmungen bezüglich der anlagentechnik.

NL N.B.: Bij het installeren van het systeem moet u de geldende installatienormen strikt naleven.

ES N.B.: Durante la instalación del sistema respetar e scrupulosamente las normas de instalación vigentes.

DA N.B.: Under installation af systemet skal man nøje overholde de gældende regler for disse anlæg.

NO N.B.: Ved installasjon av systemet skal alle forskrifter om installasjon som gjelder følges strengt.

SV OBS.: Under installationen av systemet ska installationsföreskrifterna respekteras i detalj.

RU примечание: в процессе монтажа системы строго соблюдайте национальные действующие нормативы по электропроводке.

ZH 注意: 在安装系统时请遵守设备的安装规定。

AR ملاحظة: أثناء تركيب النظام يجب التقيد بحرص بالنظم السائدة المتعلقة بالشبكة الكهربائية.

ART. X744 series connection

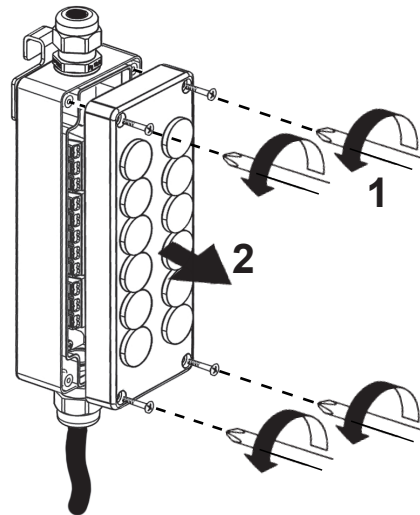

ONLY 12m POLES (Art. X733-X737-S992-S996)

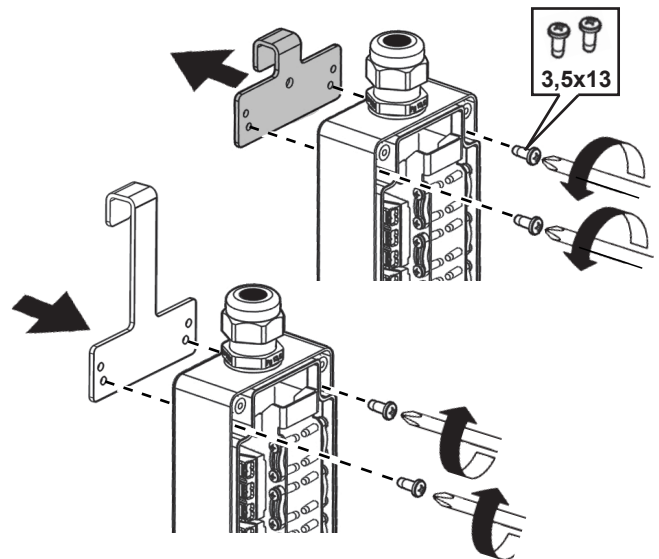
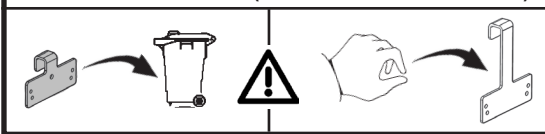

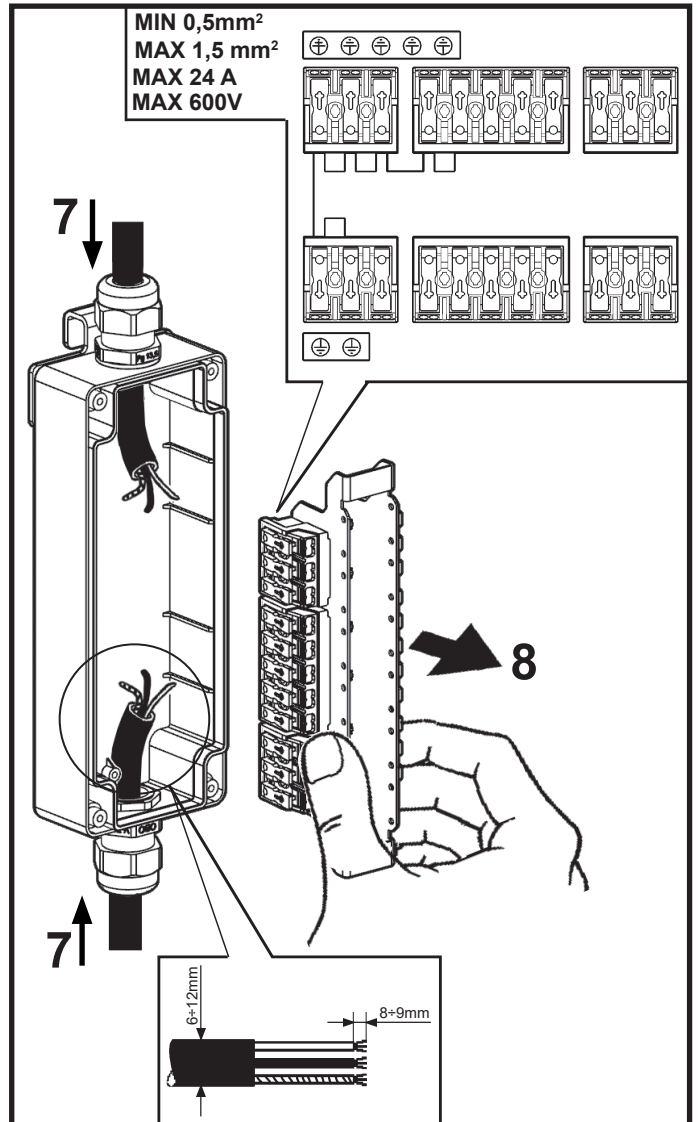
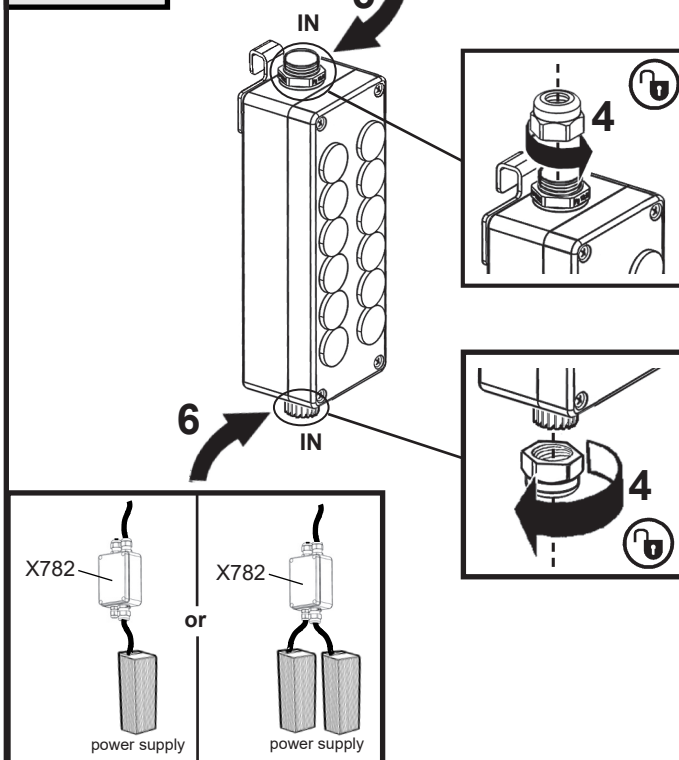
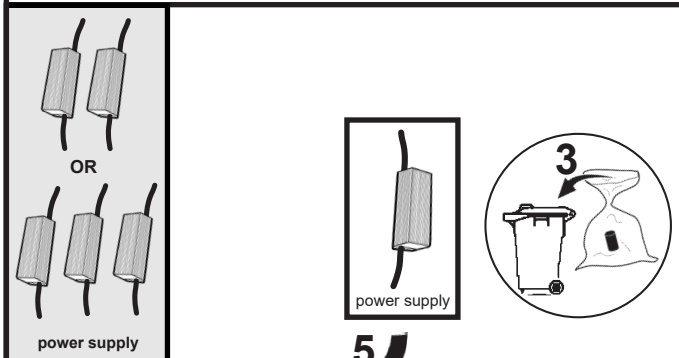
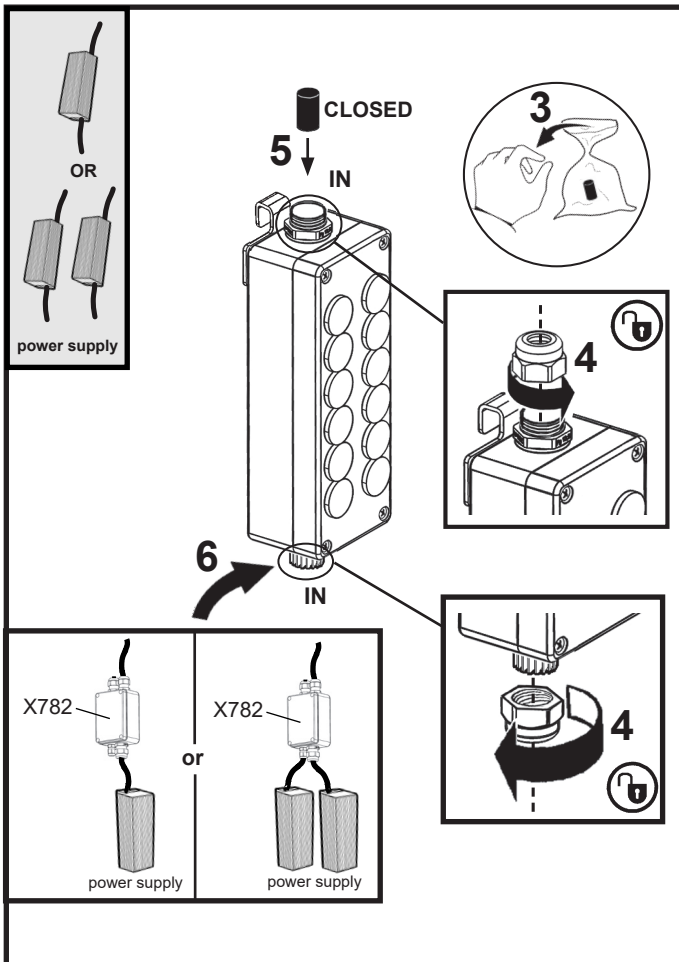

- IT N.B.: Verificare manualmente la tenuta dei cavi nel morsetto.
 EN N.B.: Manually check the tightness of the cables in the terminal board.
 FR N.B.: Veuillez vérifier manuellement la tenue des fils dans la borne.
 DE NB: Der Halt der Drähte in der Klemme ist von Hand zu prüfen.
 NL N.B.: Verifieer handmatig of de kabels goed in de klemmenstrook vastzitten.
 ES N.B.: Verificar manualmente la fijación de los cables en el terminal.
 DA N.B.: Kontroller, at ledningerne i klemmen sidder ordentligt fast.
 NO N.B.: Kontroller tettheten til kablene i terminalkortet manuelt.
 SV OBS! Kontrollera för hand att kablarna sitter ordentligt fast i klämman.
 RU ПРИМЕЧАНИЕ: Проверьте вручную прочность соединения проводов к клеммам.
 ZH 注意: 手动检查接线排电缆的牢固性。

AR تنبيه: تحقق يدويا من مناعة الكابلات داخل طرف التوصيل.



- IT Sfondare la membrana soltanto sui fori utilizzati per il passaggio dei cavi.
 EN Break the membrane only on the holes used for passing through the cables.
 FR Ne défoncer que la membrane des trous utilisés pour le passage des câbles.
 DE Die Membran nur an den für den Kabeldurchgang verwendeten Löchern durchstoßen.
 NL Prik het membraan slechts door op de gaten voor het doorlaten van de kabels.
 ES Rasgar la membrana únicamente en el lugar donde han de pasar los cables.
 DA Membranen må kun gennembrydes ved de huller, der skal anvendes til kabelføring.
 NO Lag hull på hinnene bare ved hullene som brukes for passering av kablene.
 SV Krossa endast membranet vid hålen som används för kabelföringen.
 RU Продавите мембрану только в точках, используемых для пропускания проводов
 ZH 只在用于通过电缆的孔处冲破薄膜。
 AR اكسر الغشاء الموجود فقط على الفتحات المستخدمة لإدخال الكابلات.

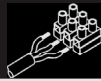

CONNECTOR EXAMPLE WITH



series connection

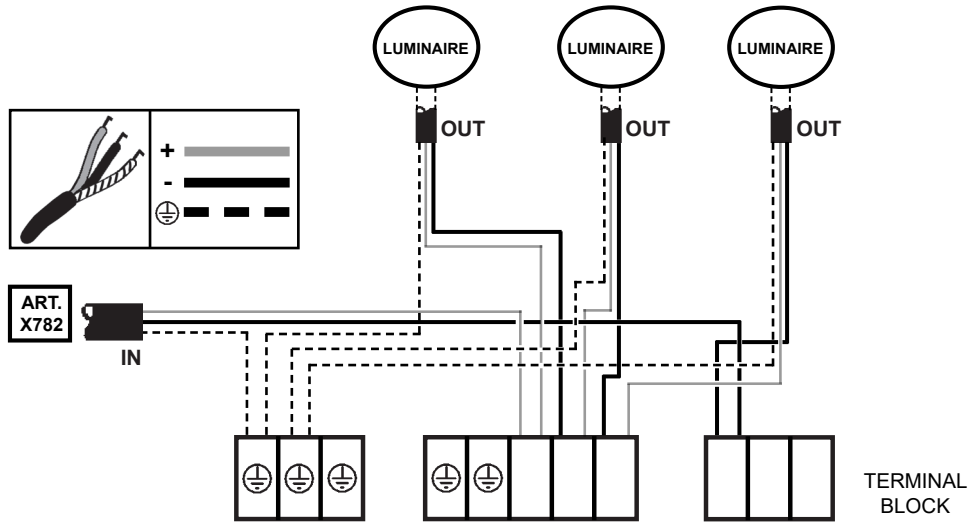

CONNECTOR EXAMPLE WITH

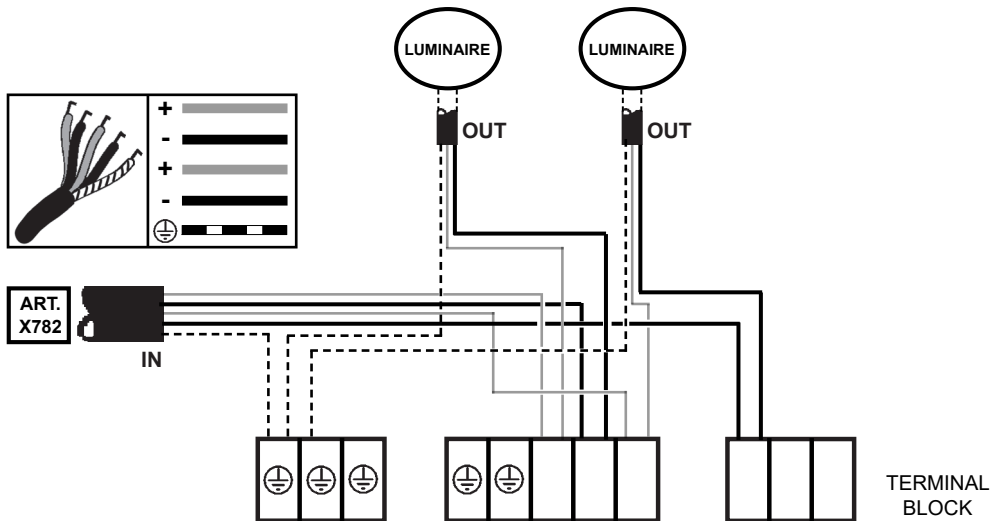

CONNECTOR EXAMPLE WITH

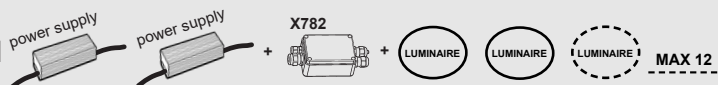

series connection

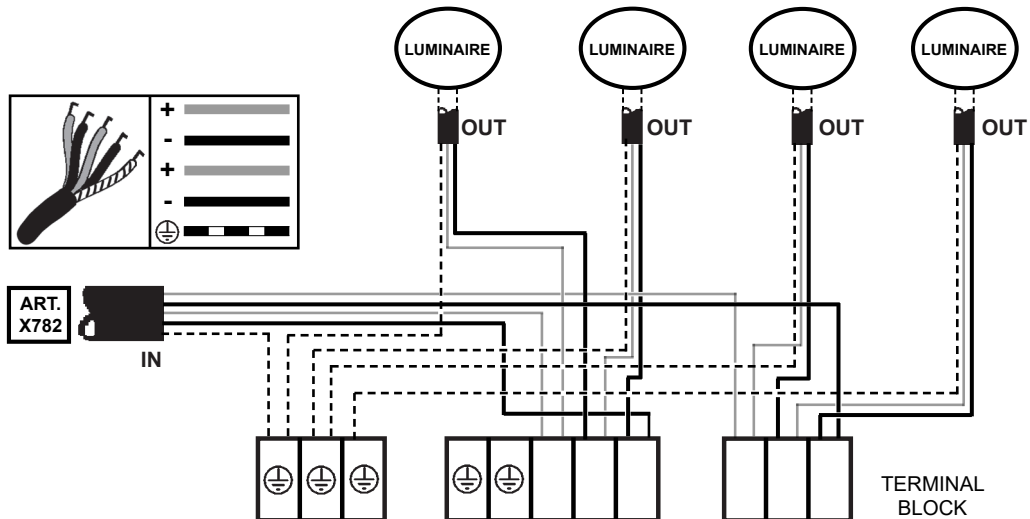

CONNECTOR EXAMPLE WITH

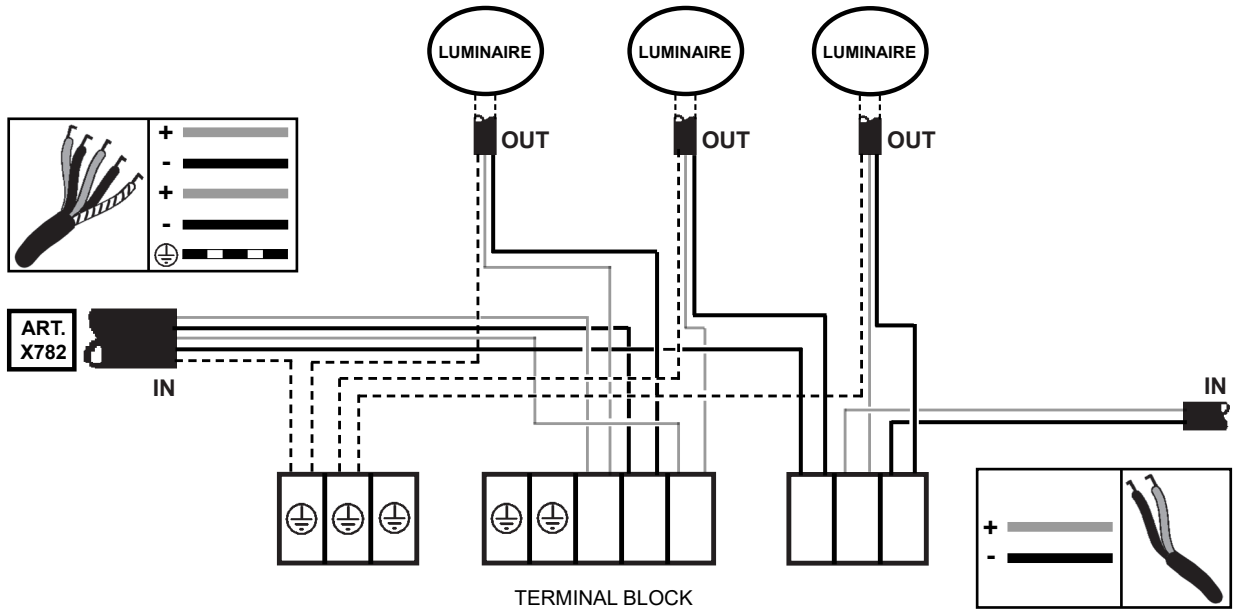
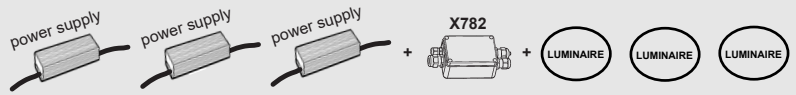

CONNECTOR EXAMPLE WITH

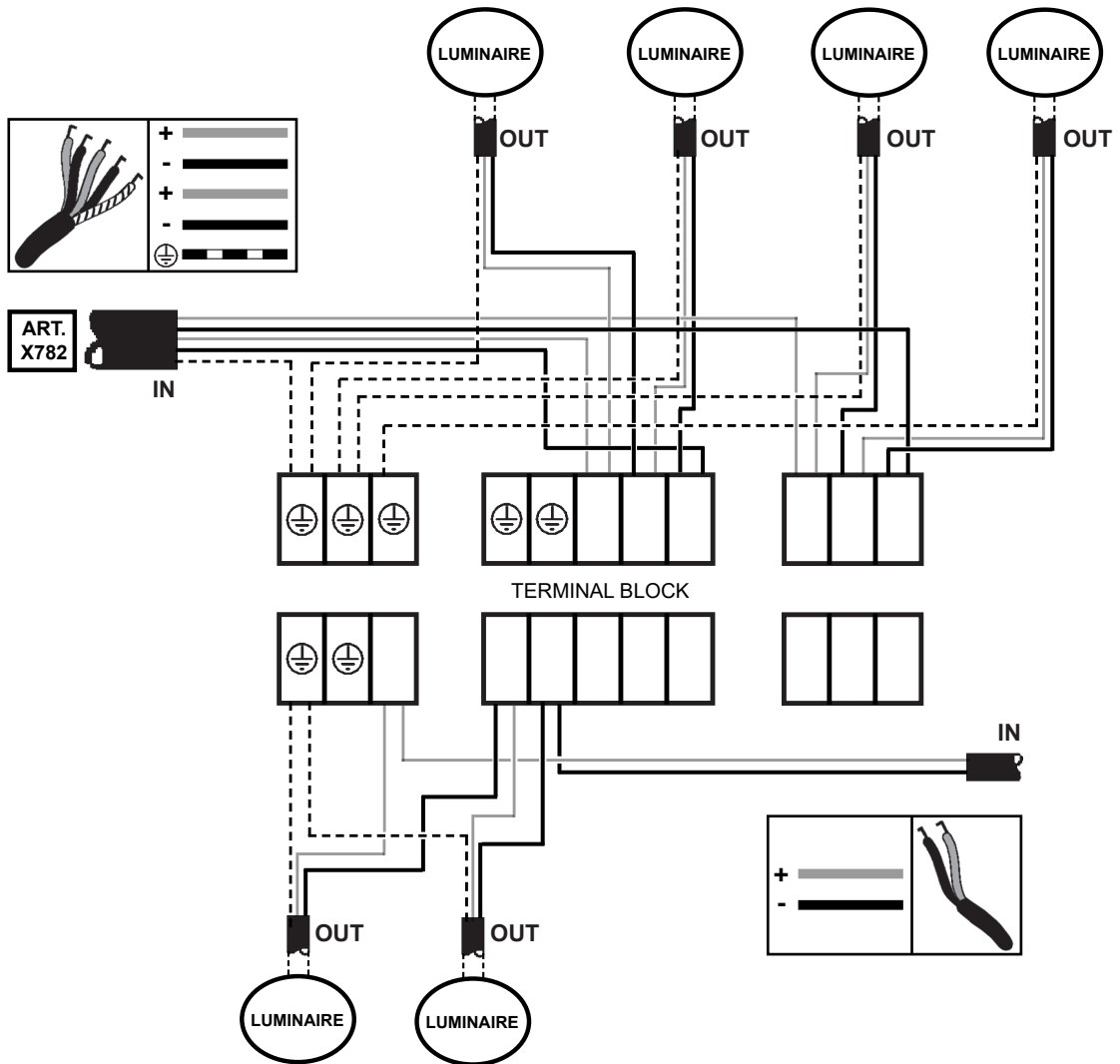
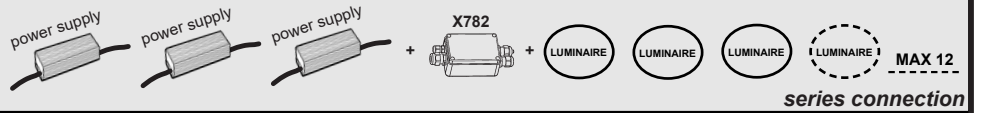

ONLY 5-7-9m POLES
 (Art. X730-X731-X732-X734-X735-X736
 S989-S990-S991-S993-S994-S995)

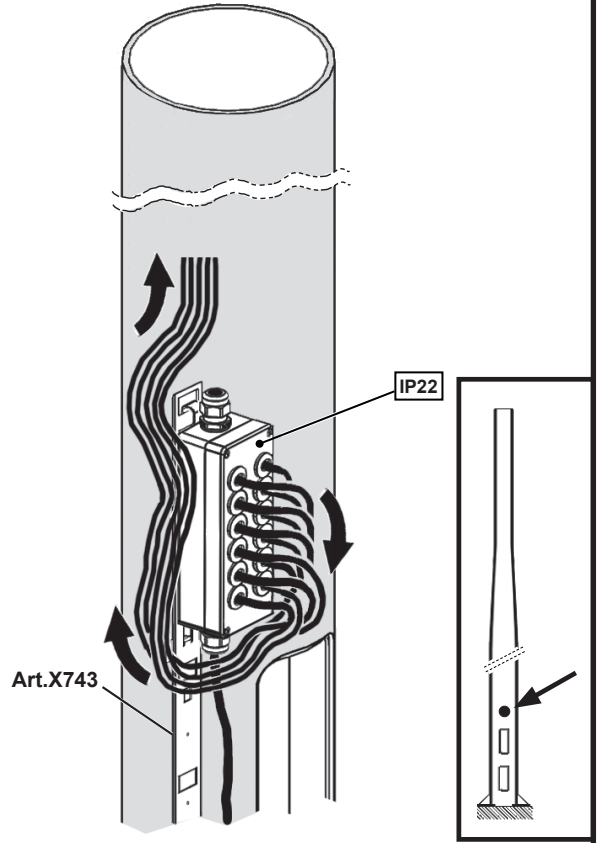
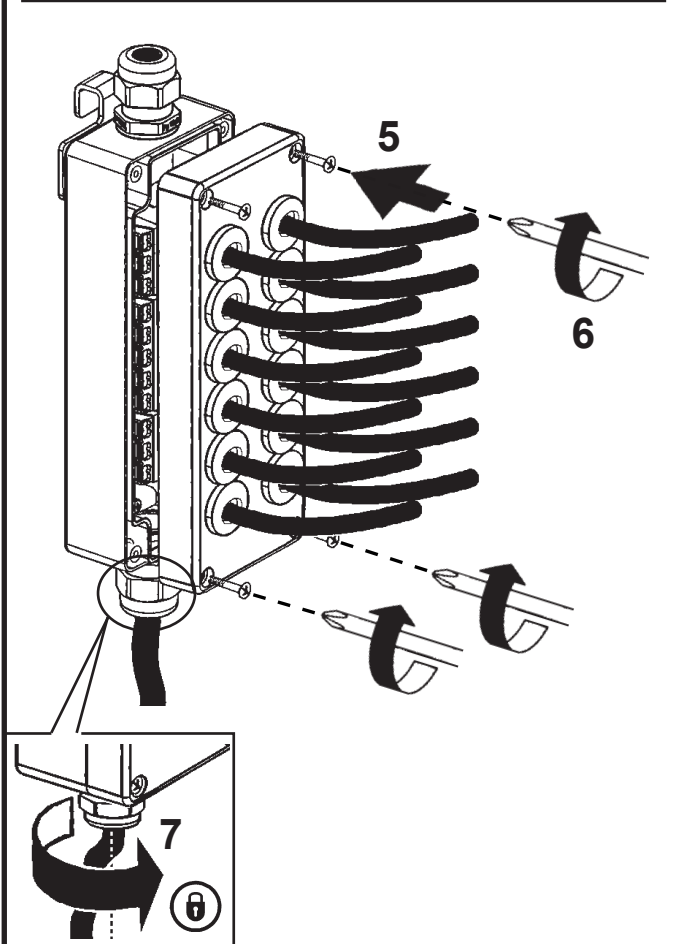
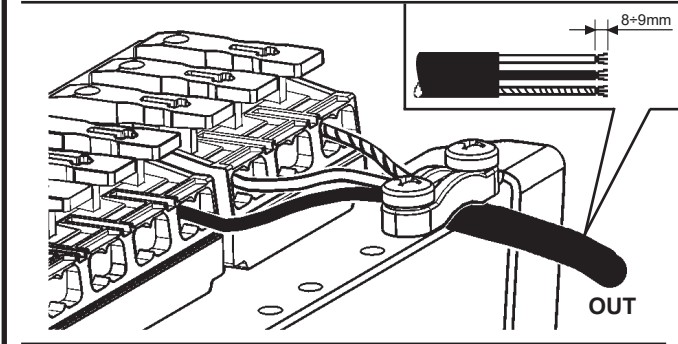
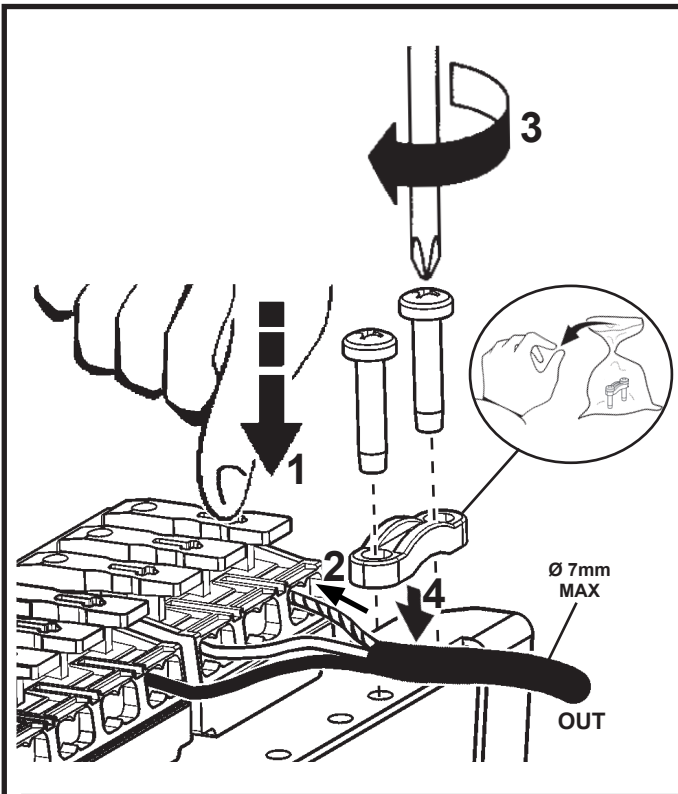

ONLY 12m POLES
 (Art. X733-X737-S992-S996)

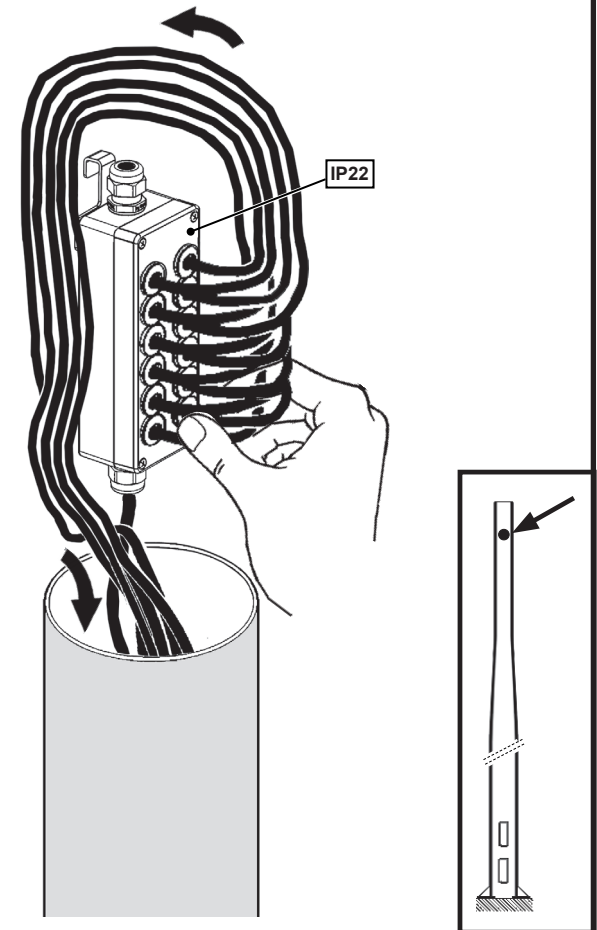

ART. X745
parallel connection

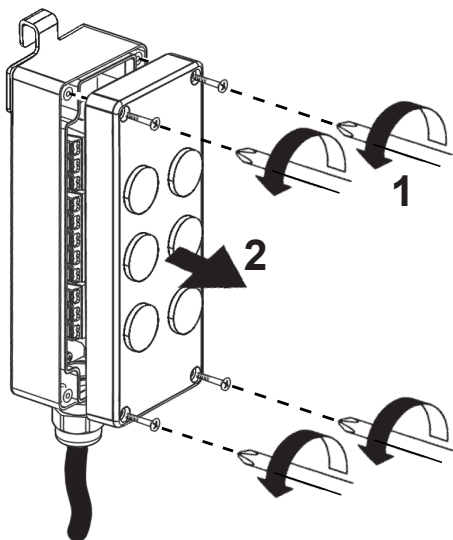

ONLY 12m POLES
(Art. X733-X737-S992-S996)

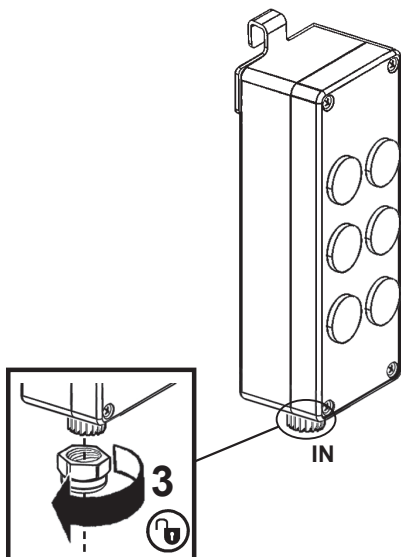
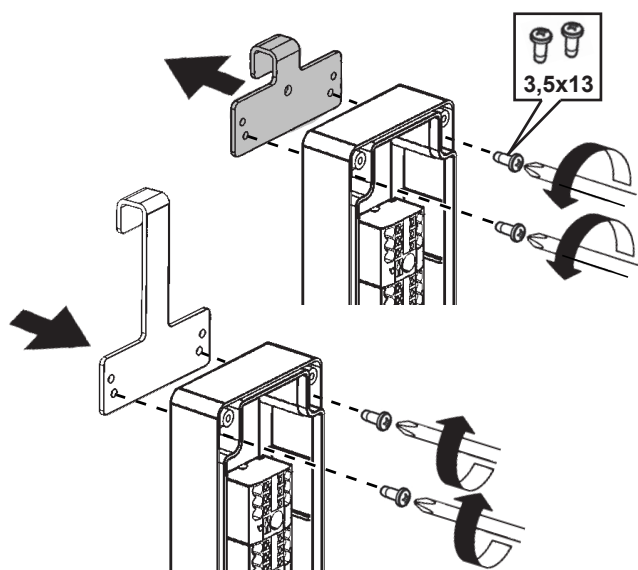
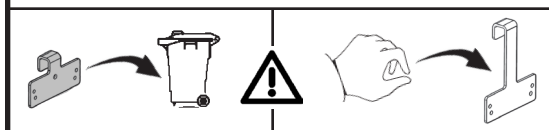

MIN 0,5 mm² - MAX 6 mm² (IN)
MAX 2,5 mm² (OUT)
MAX 12 A
MAX 450V

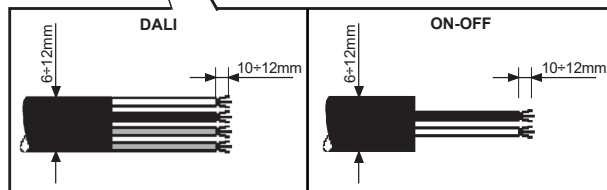
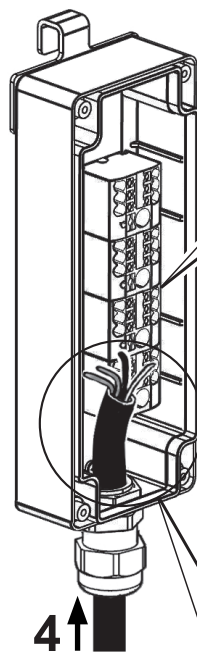
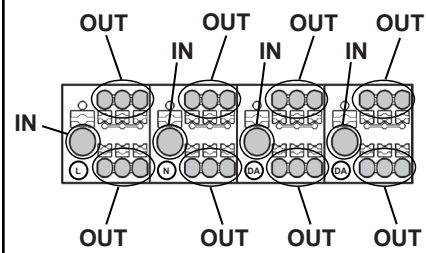

- IT N.B.: Verificare manualmente la tenuta dei cavi nel morsetto.
EN N.B.: Manually check the tightness of the cables in the terminal board.
FR N.B.: Veuillez vérifier manuellement la tenue des fils dans la borne.
DE NB: Der Halt der Drähte in der Klemme ist von Hand zu prüfen.
NL N.B.: Verifieer handmatig of de kabels goed in de klemmenstrook vastzitten.
ES N.B.: Verificar manualmente la fijación de los cables en el terminal.
DA N.B.: Kontroller, at ledningerne i klemmen sidder ordentligt fast.
NO N.B.: Kontroller tettheten til kablene i terminalkortet manuelt.
SV OBS! Kontrollera för hand att kablarna sitter ordentligt fast i klämman.
RU ПРИМЕЧАНИЕ: Проверьте вручную прочность соединения проводов к клеммам.
ZH 注意：手动检查接线排电缆的牢固性。

AR تنبيه: تحقق يدويا من مناعة الكابلات داخل طرف التوصيل.

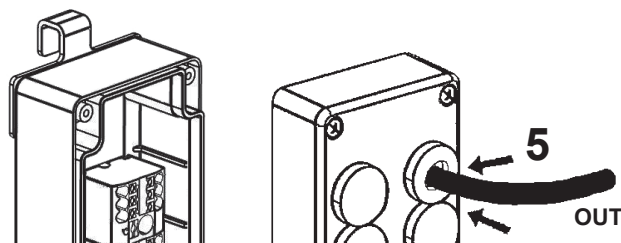

- IT Sfondare la membrana soltanto sui fori utilizzati per il passaggio dei cavi.
EN Break the membrane only on the holes used for passing through the cables.
FR Ne défoncer que la membrane des trous utilisés pour le passage des câbles.
DE Die Membran nur an den für den Kabeldurchgang verwendeten Löchern durchstoßen.
NL Prik het membraan slechts door op de gaten voor het doorlaten van de kabels.
ES Rasgar la membrana únicamente en el lugar donde han de pasar los cables.
DA Membranen må kun gennembrydes ved de huller, der skal anvendes til kabelføring.
NO Lag hull på hinnene bare ved hullene som brukes for passering av kablene.
SV Krossa endast membranet vid hålen som används för kabelföringen.
RU Продавите мембрану только в точках, используемых для пропускания проводов
ZH 只在用于通过电缆的孔处冲破薄膜。

AR اكسر الغشاء الموجود فقط على الفتحات المستخدمة لإدخال الكابلات.

CONNECTOR EXAMPLE WITH



MIN 3
MAX 6

parallel connection

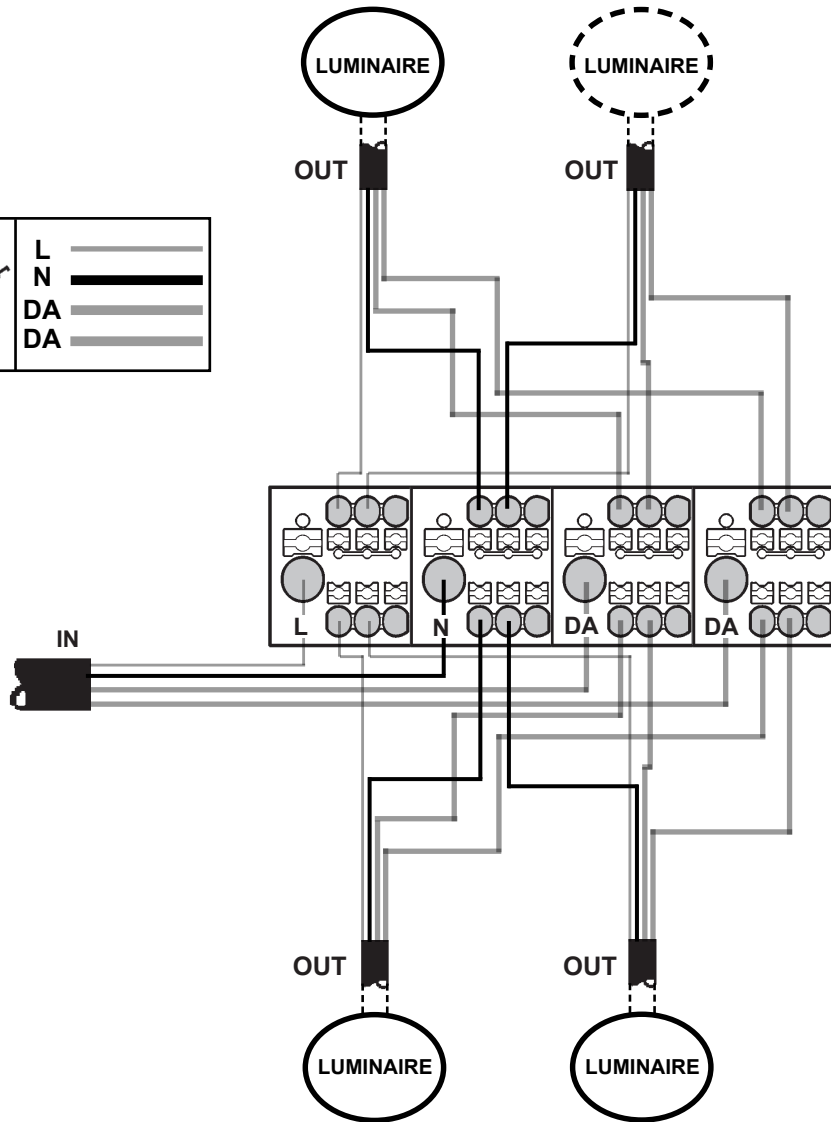
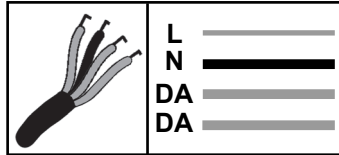

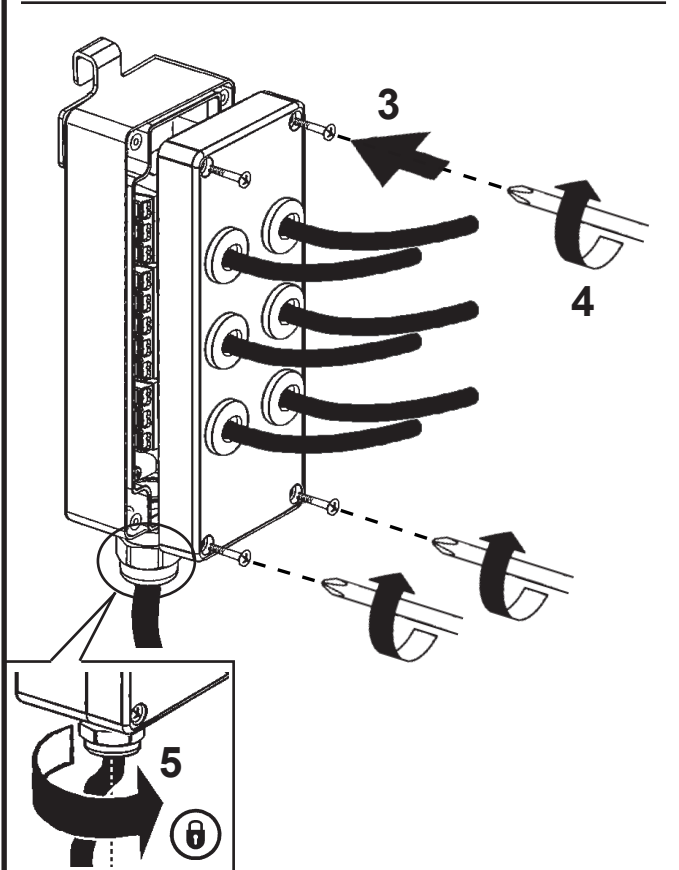
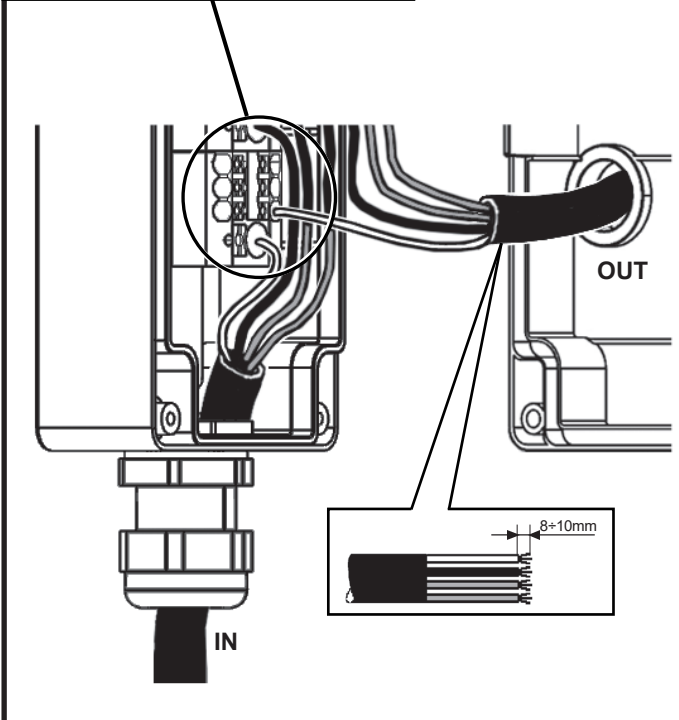
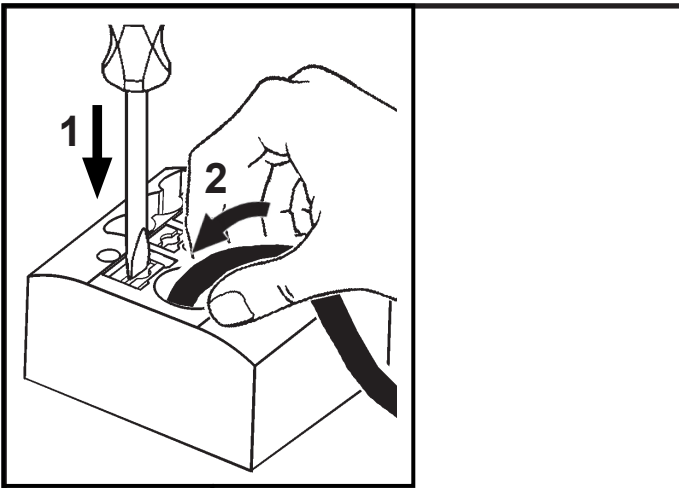

ONLY 5-7-9m POLES
 (Art. X730-X731-X732-X734-X735-X736
 S989-S990-S991-S993-S994-S995)

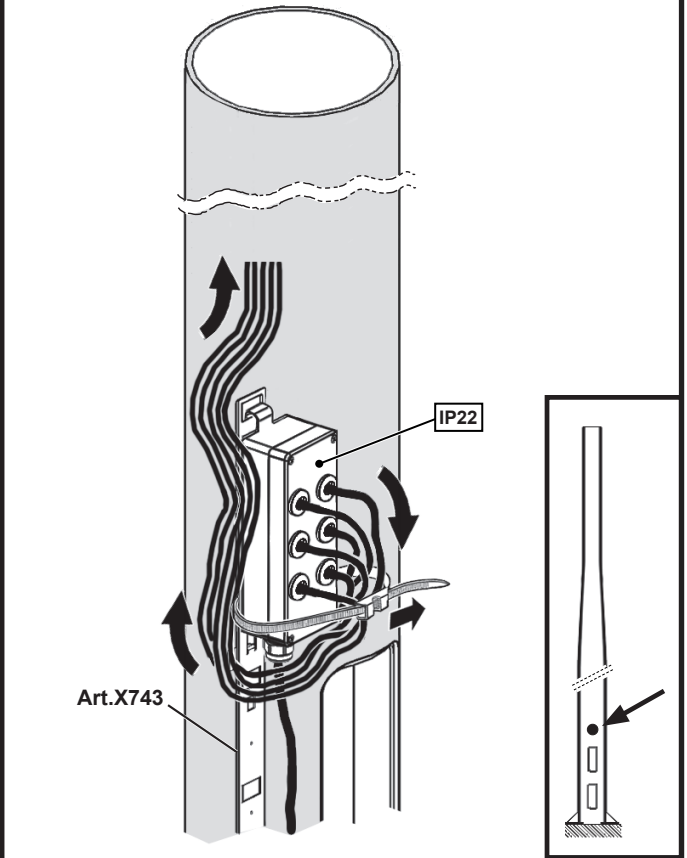

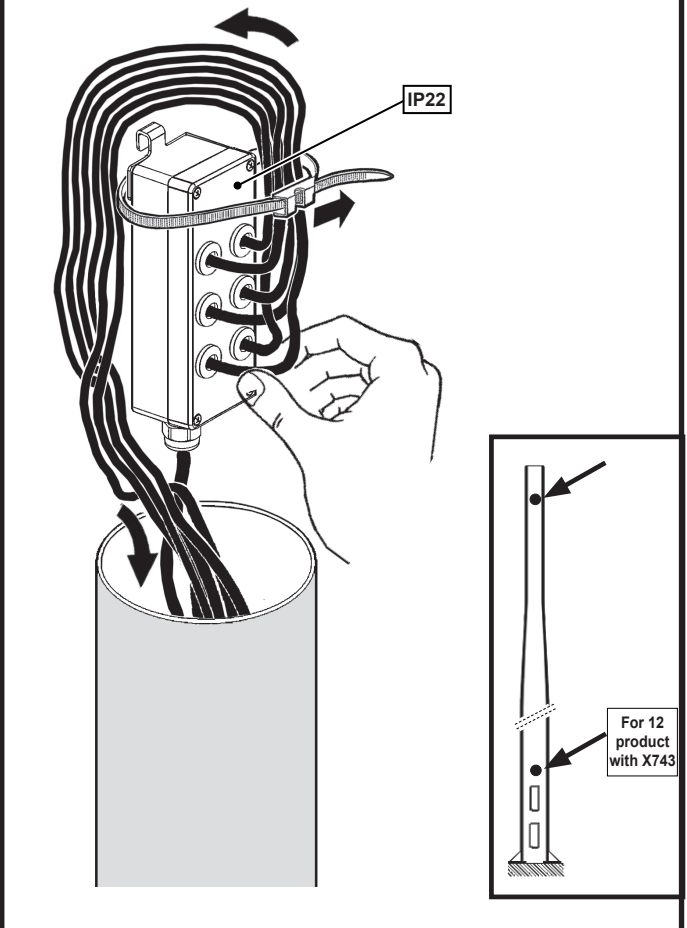

ONLY 12m POLES
 (Art. X733-X737-S992-S996)

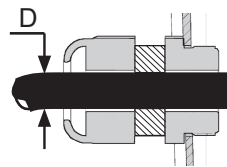
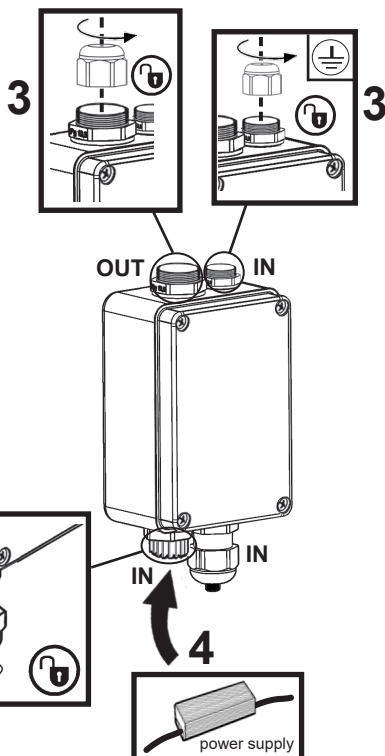
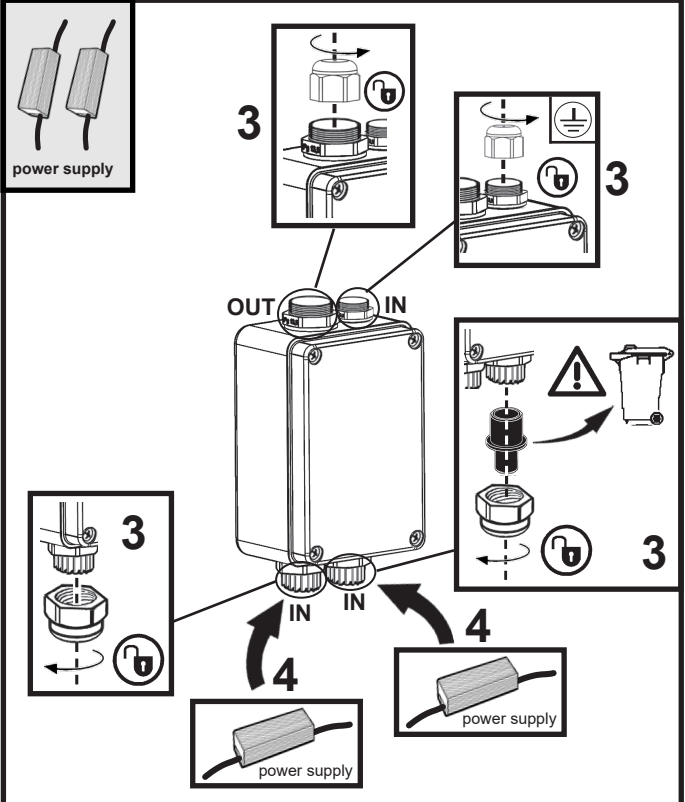
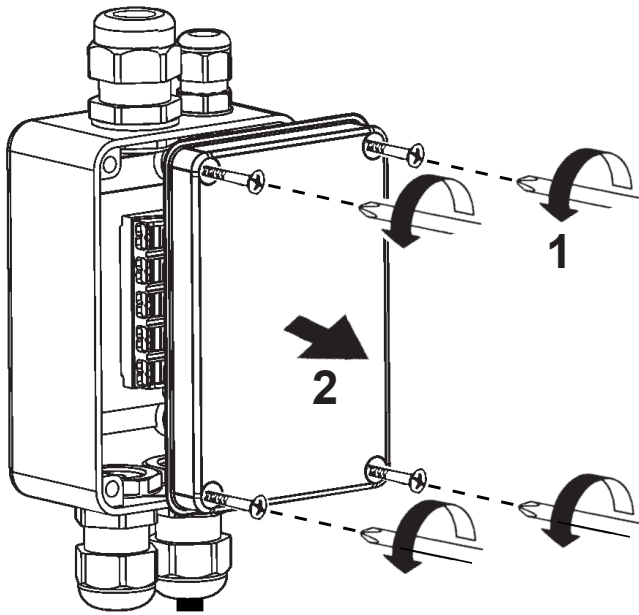

ART. X782
ground box



	D (mm)	Ø
IN 	4 ÷ 10	PG 11
IN 	2 ÷ 5	M12
OUT	6 ÷ 12	PG 13,5

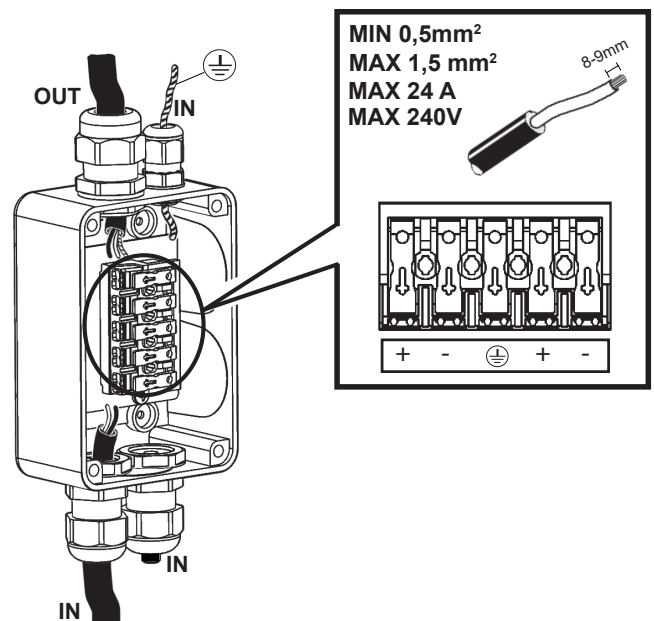

- IT N.B.: Verificare manualmente la tenuta dei cavi nel morsetto.
 EN N.B.: Manually check the tightness of the cables in the terminal board.
 FR N.B.: Veuillez vérifier manuellement la tenue des fils dans la borne.
 DE NB: Der Halt der Drähte in der Klemme ist von Hand zu prüfen.
 NL N.B.: Verifieer handmatig of de kabels goed in de klemmenstrook vastzitten.
 ES N.B.: Verificar manualmente la fijación de los cables en el terminal.
 DA N.B.: Kontroller, at ledningerne i klemmen sidder ordentligt fast.
 NO N.B.: Kontroller tettheten til kablene i terminalkortet manuelt.
 SV OBS! Kontrollera för hand att kablarna sitter ordentligt fast i klämman.
 RU ПРИМЕЧАНИЕ: Проверьте вручную прочность соединения проводов к клеммам.
 ZH 注意：手动检查接线排电缆的牢固性。

CONNECTOR EXAMPLE WITH

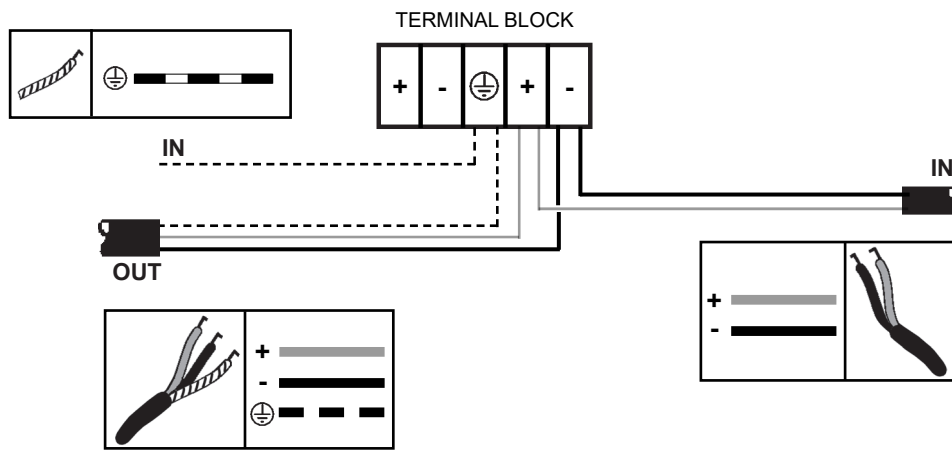

CONNECTOR EXAMPLE WITH

